



ТЕЛЕФОНЫ

(044) 360-7-130
(050) 336-0-130
(063) 788-0-130
(067) 233-0-130
(068) 282-0-130

130
COM.UA

Интернет-магазин
автотоваров



ICO
294-0-130
597-0-130

SKYPE
km-130

АВТОМАГНИТОЛЫ — Магнитолы • Медиа-ресиверы и станции • Штатные магнитолы • CD/DVD чейнджеры • FM-модуляторы/USB адаптеры • Flash память • Переходные рамки и разъемы • Антенны • Аксессуары | **АВТОЗВУК** — Акустика • Усилители • Сабвуферы • Процессоры • Кроссоверы • Наушники • Аксессуары | **БОРТОВЫЕ КОМПЬЮТЕРЫ** — Универсальные компьютеры • Модельные компьютеры • Аксессуары | **GPS НАВИГАТОРЫ** — Портативные GPS • Встраиваемые GPS • GPS модули • GPS трекеры • Антенны для GPS навигаторов • Аксессуары | **ВИДЕОУСТРОЙСТВА** — Видеорегистраторы • Телевизоры и мониторы • Автомобильные ТВ тюнеры • Камеры • Видеомодули • Транскодеры • Автомобильные ТВ антенны • Аксессуары | **ОХРАННЫЕ СИСТЕМЫ** — Автосигнализации • Мотосигнализации • Механические блокираторы • Имобилайзеры • Датчики • Аксессуары | **ОПТИКА И СВЕТ** — Ксенон • Биксенон • Лампы • Светодиоды • Стробоскопы • Оптика и фары • Омыватели фар • Датчики света, дождя • Аксессуары | **ПАРКТРОНИКИ И ЗЕРКАЛА** — Задние парктроники • Передние парктроники • Комбинированные парктроники • Зеркала заднего вида • Аксессуары | **ПОДОГРЕВ И ОХЛАЖДЕНИЕ** — Подогревы сидений • Подогревы зеркал • Подогревы дворников • Подогревы двигателей • Автохолодильники • Автокондиционеры • Аксессуары | **ТЮНИНГ** — Виброизоляция • Шумоизоляция • Тонировочная пленка • Аксессуары | **АВТОАКСЕССУАРЫ** — Радар-детекторы • Громкая связь Bluetooth • Стеклоподъемники • Компрессоры • Звуковые сигналы, СГУ • Измерительные приборы • Автопылесосы • Автокресла • Разное | **МОНТАЖНОЕ ОБОРУДОВАНИЕ** — Установочные комплекты • Обивочные материалы • Декоративные решетки • Фазоинверторы • Кабель и провод • Инструменты • Разное | **ПИТАНИЕ** — Аккумуляторы • Преобразователи • Пуско-зарядные устройства • Конденсаторы • Аксессуары | **МОРСКАЯ ЭЛЕКТРОНИКА И ЗВУК** — Морские магнитолы • Морская акустика • Морские сабвуферы • Морские усилители • Аксессуары | **АВТОХИМИЯ И КОСМЕТИКА** — Присадки • Жидкости омывателя • Средства по уходу • Полироли • Ароматизаторы • Клеи и герметики | **ЖИДКОСТИ И МАСЛА** — Моторные масла • Трансмиссионные масла • Тормозные жидкости • Антифризы • Технические смазки



В магазине «130» вы найдете и сможете купить в Киеве с доставкой по городу и Украине практически все для вашего автомобиля. Наши опытные консультанты предоставят вам исчерпывающую информацию и помогут подобрать именно то, что вы ищете. Ждем вас по адресу

<http://130.com.ua>

FOR CAR USE ONLY/NUR FÜR AUTOMOBIL GEBRAUCH/POUR APPLICATION AUTOMOBILE UNIQUEMENT/
PARA USO EN AUTOMÓVILES/SOLO PER L'UTILIZZO IN AUTOMOBILE/ENDAST FÖR BILBRUK/ALLEEN VOOR
GEBRUIK IN DE AUTO/ТОЛЬКО ДЛЯ ИСПОЛЬЗОВАНИЯ В АВТОМОБИЛЯХ/DO UŻYCIA TYLKO W
SAMOCHODZIE



RU

iLX-700

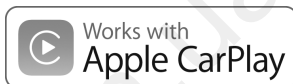

Alpine Tunelt App

QUICK REFERENCE GUIDE

Kurzanleitung

GUIDE DE RÉFÉRENCE RAPIDE

GUÍA DE REFERENCIA RÁPIDA

GUIDA RAPIDA

SNABBGUIDE

SNELSTARTGIDS

КРАТКОЕ СПРАВОЧНОЕ РУКОВОДСТВО

SKRÓCONA INSTRUKCJA DLA UŻYTKOWNIKA

130.com.ua

Contents

WARNING	2
CAUTION	2
Getting Started	3
Features	4
Radio/RDS Operation	5
Apple CarPlay Operation (Optional).....	6
Auxiliary Device Operation (Optional)	6
Installation.....	7
Connections.....	9
Specifications	10

IMPORTANT

Please record the serial number of your unit in the space provided below and keep it as a permanent record.

SERIAL NUMBER: _____

ISO SERIAL NUMBER: AL _____

INSTALLATION DATE: _____

INSTALLATION TECHNICIAN: _____

PLACE OF PURCHASE: _____

For details on all functions, refer to the Owner's Manual published on our website at: <http://www.alpine-europe.com>. If required, an ALPINE dealer will readily provide you with a print out of the Owner's Manual published on the website.

WARNING



This symbol means important instructions. Failure to heed them can result in serious injury or death.

DO NOT OPERATE ANY FUNCTION THAT TAKES YOUR ATTENTION AWAY FROM SAFELY DRIVING YOUR VEHICLE.

Any function that requires your prolonged attention should only be performed after coming to a complete stop. Always stop the vehicle in a safe location before performing these functions. Failure to do so may result in an accident.

KEEP SMALL OBJECTS SUCH AS SCREWS OUT OF THE REACH OF CHILDREN.

Swallowing them may result in serious injury. If swallowed, consult a physician immediately.

KEEP THE VOLUME AT A LEVEL WHERE YOU CAN STILL HEAR OUTSIDE NOISES WHILE DRIVING.

Excessive volume levels that obscure sounds such as emergency vehicle sirens or road warning signals (train crossings, etc.) can be dangerous and may result in an accident. LISTENING AT LOUD VOLUME LEVELS IN A CAR MAY ALSO CAUSE HEARING DAMAGE.

DO NOT DISASSEMBLE OR ALTER.

Doing so may result in an accident, fire or electric shock.

USE ONLY IN CARS WITH A 12 VOLT NEGATIVE GROUND.

(Check with your dealer if you are not sure.) Failure to do so may result in fire, etc.

USE THE CORRECT AMPERE RATING WHEN REPLACING FUSES.

Failure to do so may result in fire or electric shock.

DO NOT BLOCK VENTS OR RADIATOR PANELS.

Doing so may cause heat to build up inside and may result in fire.

USE THIS PRODUCT FOR MOBILE 12V APPLICATIONS.

Use for other than its designed application may result in fire, electric shock or other injury.

DO NOT PLACE HANDS, FINGERS OR FOREIGN OBJECTS IN INSERTION SLOTS OR GAPS.

Doing so may result in personal injury or damage to the product.

MAKE THE CORRECT CONNECTIONS.

Failure to make the proper connections may result in fire or product damage.

BEFORE WIRING, DISCONNECT THE CABLE FROM THE NEGATIVE BATTERY TERMINAL.

Failure to do so may result in electric shock or injury due to electrical shorts.

DO NOT SPLICE INTO ELECTRICAL CABLES.

Never cut away cable insulation to supply power to other equipment. Doing so will exceed the current carrying capacity of the wire and result in fire or electric shock.

DO NOT DAMAGE PIPE OR WIRING WHEN DRILLING HOLES.

When drilling holes in the chassis for installation, take precautions so as not to contact, damage or obstruct pipes, fuel lines, tanks or electrical wiring. Failure to take such precautions may result in fire.

DO NOT USE BOLTS OR NUTS IN THE BRAKE OR STEERING SYSTEMS TO MAKE GROUND CONNECTIONS.

Bolts or nuts used for the brake or steering systems (or any other safety-related system), or tanks should NEVER be used for installations or ground connections. Using such parts could disable control of the vehicle and cause fire, etc.

DO NOT INSTALL IN LOCATIONS WHICH MIGHT HINDER VEHICLE OPERATION, SUCH AS THE STEERING WHEEL OR SHIFT LEVER.

Doing so may obstruct forward vision or hamper movement etc., and results in serious accident.



This symbol means important instructions. Failure to heed them can result in injury or material property damage.

HALT USE IMMEDIATELY IF A PROBLEM APPEARS.

Failure to do so may cause personal injury or damage to the product. Return it to your authorized Alpine dealer or the nearest Alpine Service Centre for repairing.

HAVE THE WIRING AND INSTALLATION DONE BY EXPERTS.

The wiring and installation of this unit requires special technical skill and experience. To ensure safety, always contact the dealer where you purchased this product to have the work done.

USE SPECIFIED ACCESSORY PARTS AND INSTALL THEM SECURELY.

Be sure to use only the specified accessory parts. Use of other than designated parts may damage this unit internally, or may not securely install the unit in place. This may cause parts to become loose resulting in hazards or product failure.

ARRANGE THE WIRING SO IT IS NOT CRIMPED OR PINCHED BY A SHARP METAL EDGE.

Route the cables and wiring away from moving parts (like the seat rails) or sharp or pointed edges. This will prevent crimping and damage to the wiring. If wiring passes through a hole in metal, use a rubber grommet to prevent the wire's insulation from being cut by the metal edge of the hole.

DO NOT INSTALL IN LOCATIONS WITH HIGH MOISTURE OR DUST.



Avoid installing the unit in locations with high incidence of moisture or dust. Moisture or dust that penetrates into this unit may result in product failure.

Getting Started

Touch operation

You can operate the system by using the touch panel on the screen.

■ Common onscreen buttons

-  : Returns to the previous screen. Depending on the function, this button may cancel the operations performed on the screen.
-  : Closes the window.

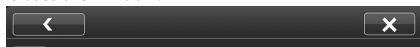

Location of Controls

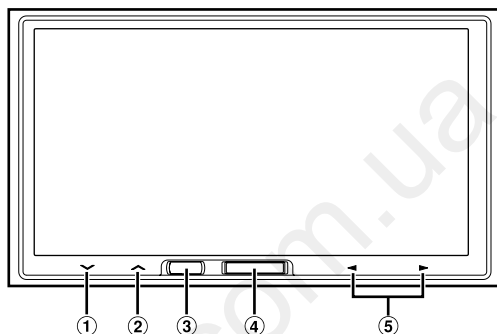

- ① **▼ button**
Touch to turn down the volume. Touch and hold for at least 2 seconds to mute.
- ② **▲ button**
Touch to turn up the volume.
- ③ **Siri button**
Starts the Siri function of the iPhone.
- ④ **Home button**
Press to call up the Home Screen.
Press and hold for at least 5 seconds to turn the power off.
- ⑤ **◀/▶ button**
This action varies according to the Audio/Visual application.
(Track Up/Down, Fast reverse/Fast forward, etc.)

- You can reset the unit by pressing and holding Home and Siri buttons at the same time for 10 seconds.

Turning Power On or Off

- 1 Turn the ignition key to the ACC or ON position.**
The system is turned on.
- 2 Press and hold the Home button for at least 5 seconds to turn the power off.**

Features

About Apple CarPlay

Apple CarPlay allows your iPhone 5 or later to operate smoothly from this head unit.

About Home Screen

The Home Screen for this unit gives direct access to those applications designed to work with Apple CarPlay. The Apple CarPlay icon will indicate whether the appropriate iPhone is connected.

■ When iPhone is connected



■ When iPhone is not connected



Radio/RDS Operation

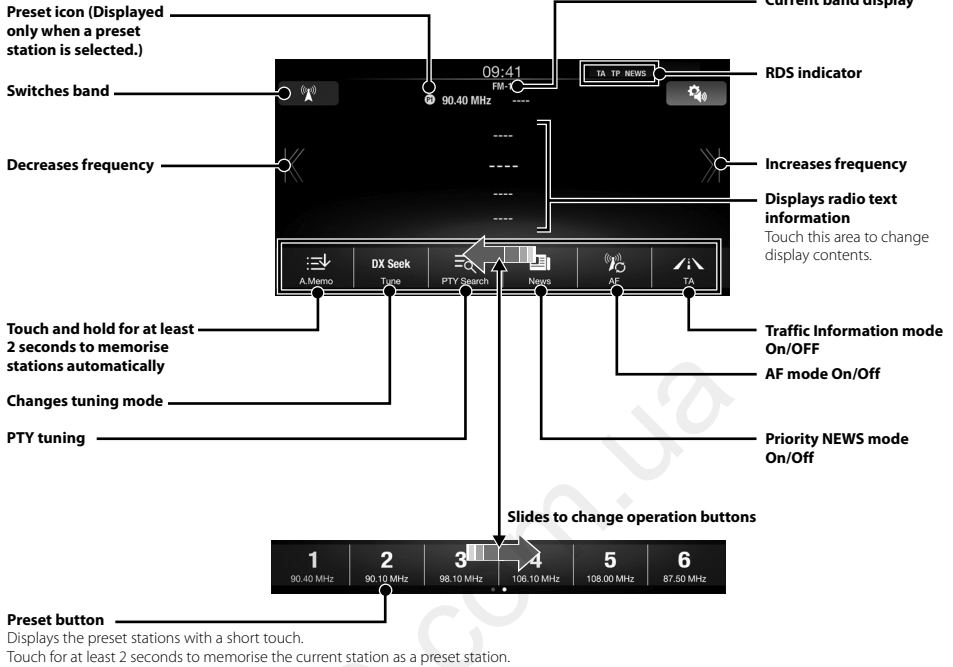

Preset button
 Displays the preset stations with a short touch.
 Touch for at least 2 seconds to memorise the current station as a preset station.

Apple CarPlay Operation (Optional)

Apple CarPlay is a smarter, safer way to use your iPhone in the car. Apple CarPlay takes the things you want to do with your iPhone while driving and puts them right on iLX-700. You can get directions, make calls, send and receive messages, and listen to music, all in a way that allows you to stay focused on the road. Just plug in your iPhone to iLX-700 and go.

For details, refer to Owner's Manual published on our website.



Siri button

Press to activate Siri function of the iPhone.

You can make a call, play music, etc., by using Siri function of the iPhone.

You can also control Apple CarPlay on touchscreen.

Auxiliary Device Operation (Optional)

Use the AUX INPUT terminal to input your favourite Audio/Video source. Use of appropriate adapters may be required.

For details, refer to Owner's Manual published on our website.

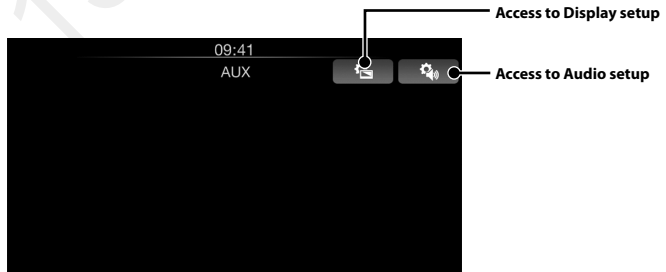

Installation

Note on installation

- Install at an angle between horizontal and 30°. Note that installing at an angle outside of this range will result in a loss of performance and possible damage.

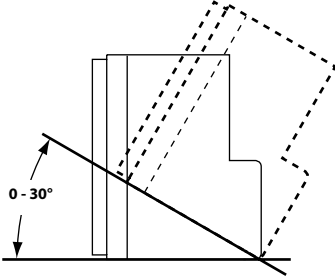

- Do not block the unit's heat sink, which would prevent air circulation. If blocked, heat will accumulate inside the unit and may cause a fire.

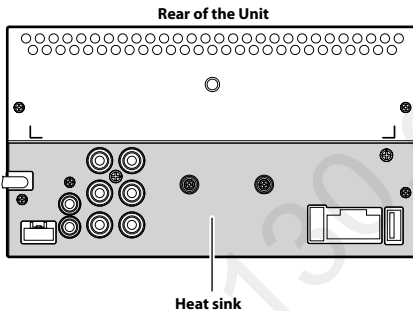

Mounting the Microphone

For safe use, make sure of the following:

- Location is stable and firm.
- Driver's view and operations are not obstructed.
- Microphone is located where the driver's voice can be easily picked up (for example, on the sun visor).

When you speak into the microphone, you should not have to change your driving posture. This may cause a distraction, taking your attention away from safely driving your vehicle. Carefully consider direction and distance while mounting the microphone. Confirm that the driver's voice can be easily picked up at the selected location.

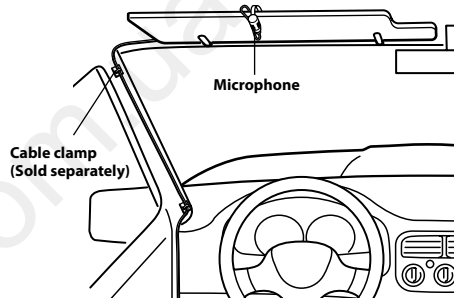

Uninstalling the original car stereo

- 1 Uninstall the car stereo with its mounting bracket.**
- 2 Remove the cables and the mounting bracket attached to the car stereo.**
(The mounting bracket will be used in "Installing the unit.")

Installing the Unit

- 1 Remove the Face Plate from the unit.
- 2 Mount the original mounting bracket to the unit using the supplied screws.

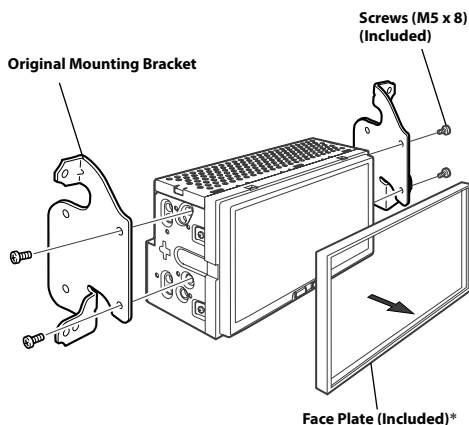

- 3 Connect all other leads of the unit according to details described in the "Connections" section (page 9).
- 4 Mounting the unit in a car.

* Use the removed Face Plate if needed.

Fix the Cables etc.

Fix the cables carefully. Do not damage them by tucking them into movable parts, such as a seat rail, or by locating them against sharp or pointed edges.

Connection Diagram of SPST Switch (sold separately)

(If the ACC power supply is not available)

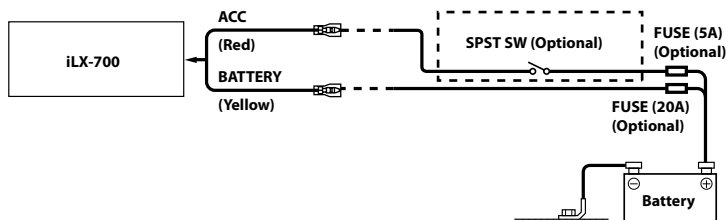

- If your vehicle has no ACC power supply, add an SPST (Single-Pole, Single-Throw) switch (sold separately) and fuse (sold separately).
- The diagram and the fuse amperage shown above are in the case when iLX-700 is used individually.
- If the switched power (ignition) lead of the iLX-700 is connected directly to the positive (+) post of the vehicle's battery, the iLX-700 draws some current (several hundred milliamperes) even when its switch is placed in the OFF position, and the battery may be discharged.

Connections

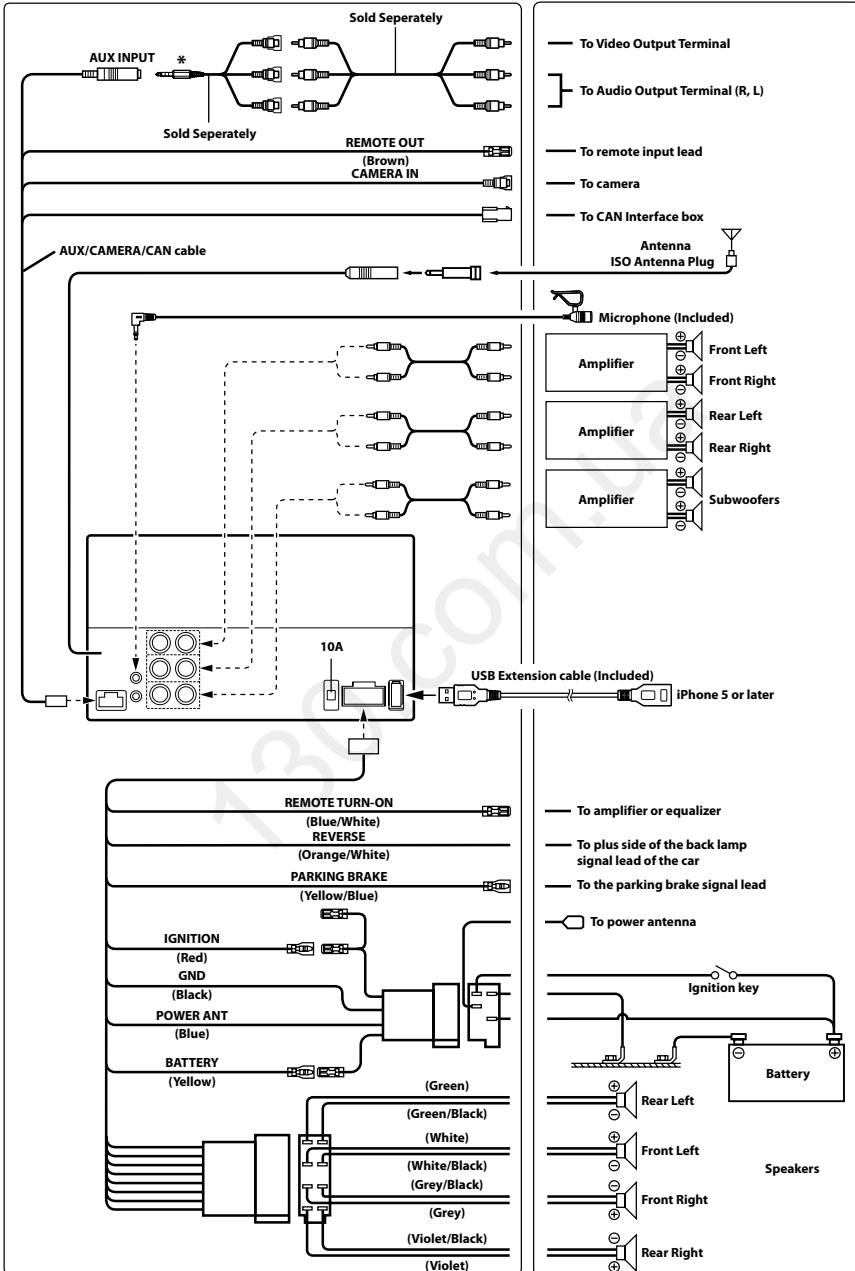

* Notice that the configuration of commercially available 4-pole mini AV plugs is not standardized. For details, refer to Owner's Manual published on our website.

Specifications

MONITOR SECTION

Screen Size	7.0"
LCD Type	Transparent type TN LCD
Operation System	TFT active matrix
Number of Picture Elements	1,152,000 pcs. (800 × 480 × 3 (RGB))
Effective Number of Picture Elements	99% or more
Illumination System	LED

FM TUNER SECTION

Tuning Range	87.5 – 108.0 MHz
Mono Usable Sensitivity	8.1 dBf (0.7 μV/75 ohms)
Alternate Channel Selectivity	80 dB
Signal-to-Noise Ratio	60 dB
Stereo Separation	35 dB
Capture Ratio	2.0 dB

MW TUNER SECTION

Tuning Range	531 – 1,602 kHz
Usable Sensitivity	25.1 μV/28 dBf

LW TUNER SECTION

Tuning Range	153 – 281 kHz
Sensitivity (IEC Standard)	31.6 μV/30 dBf

USB SECTION

USB requirements	USB 1.1/2.0
Max. Power Consumption	1,000 mA
USB Class	USB (Play From Device)/ USB (Mass Storage Class)
File System	FAT16/32

GENERAL

Power Requirement	14.4 V DC (11–16 V allowable)
Operating temperature	-4°F to +140°F (-20°C to + 60°C)
Maximum Power Output	50 W × 4
Weight	0.9 kg (1 lbs 15 oz)
Audio output level	
Preout (Front, Rear):	2V/10k ohms (max.)
Preout (Subwoofer):	2V/10k ohms (max.)

CHASSIS SIZE

Width	178 mm (7")
Height	100 mm (3-15/16")
Depth	75.5 mm (3")

- *Due to continuous product improvement, specifications and design are subject to change without notice.*
- *The LCD panel is manufactured using an extremely high precision manufacturing technology. Its effective pixel ratio is over 99.99%. This means that there is a possibility that 0.01% of the pixels could be either always ON or OFF.*
- iPhone, iTunes and CarPlay are trademarks of Apple Inc., registered in the U.S. and other countries.
- "Made for iPhone," means that an electronic accessory has been designed to connect specifically to iPhone, respectively, and has been certified by the developer to meet Apple performance standards. Apple is not responsible for the operation of this device or its compliance with safety and regulatory standards. Please note that the use of this accessory with iPhone may affect wireless performance.