



ТЕЛЕФОНЫ

(044) 338-0-130
(050) 332-0-130
(063) 577-0-130
(067) 353-0-130

130
COM.UA

Интернет-магазин
автотоваров



SKYPE
km-130

АВТОМАГНИТОЛЫ — Магнитолы • Медиа-ресиверы и станции • Штатные магнитолы • CD/DVD чейнджеры • FM-модуляторы/USB адаптеры • Flash память • Переходные рамки и разъемы • Антенны • Аксессуары | **АВТОЗВУК** — Акустика • Усилители • Сабвуферы • Процессоры • Кроссоверы • Наушники • Аксессуары | **БОРТОВЫЕ КОМПЬЮТЕРЫ** — Универсальные компьютеры • Модельные компьютеры • Аксессуары | **GPS НАВИГАТОРЫ** — Портативные GPS • Встраиваемые GPS • GPS модули • GPS трекеры • Антенны для GPS навигаторов • Аксессуары | **ВИДЕОУСТРОЙСТВА** — Видеорегистраторы • Телевизоры и мониторы • Автомобильные ТВ тюнеры • Камеры • Видеомодули • Транскодеры • Автомобильные ТВ антенны • Аксессуары | **ОХРАННЫЕ СИСТЕМЫ** — Автосигнализации • Мотосигнализации • Механические блокираторы • Имобилайзеры • Датчики • Аксессуары | **ОПТИКА И СВЕТ** — Ксенон • Биксенон • Лампы • Светодиоды • Стробоскопы • Оптика и фары • Омыватели фар • Датчики света, дождя • Аксессуары | **ПАРКТРОНИКИ И ЗЕРКАЛА** — Задние парктроники • Передние парктроники • Комбинированные парктроники • Зеркала заднего вида • Аксессуары | **ПОДОГРЕВ И ОХЛАЖДЕНИЕ** — Подогревы сидений • Подогревы зеркал • Подогревы дворников • Подогревы двигателей • Автохолодильники • Автокондиционеры • Аксессуары | **ТЮНИНГ** — Виброизоляция • Шумоизоляция • Тонировочная пленка • Аксессуары | **АВТОАКСЕССУАРЫ** — Радар-детекторы • Громкая связь Bluetooth • Стеклоподъемники • Компрессоры • Звуковые сигналы, СГУ • Измерительные приборы • Автопылесосы • Автокресла • Разное | **МОНТАЖНОЕ ОБОРУДОВАНИЕ** — Установочные комплекты • Обивочные материалы • Декоративные решетки • Фазоинверторы • Кабель и провод • Инструменты • Разное | **ПИТАНИЕ** — Аккумуляторы • Преобразователи • Пуско-зарядные устройства • Конденсаторы • Аксессуары | **МОРСКАЯ ЭЛЕКТРОНИКА И ЗВУК** — Морские магнитолы • Морская акустика • Морские сабвуферы • Морские усилители • Аксессуары | **АВТОХИМИЯ И КОСМЕТИКА** — Присадки • Жидкости омывателя • Средства по уходу • Полироли • Ароматизаторы • Клеи и герметики | **ЖИДКОСТИ И МАСЛА** — Моторные масла • Трансмиссионные масла • Тормозные жидкости • Антифризы • Технические смазки



В магазине «130» вы найдете и сможете купить в Киеве с доставкой по городу и Украине практически все для вашего автомобиля. Наши опытные консультанты предоставят вам исчерпывающую информацию и помогут подобрать именно то, что вы ищете. Ждем вас по адресу

<http://130.com.ua>

WAECO

by Dometic GROUP



CoolFreeze CDF 18, CDF 26, CDF 36, CDF 46

**RU 199 Компрессорный
холодильник**
Инструкция по эксплуатации

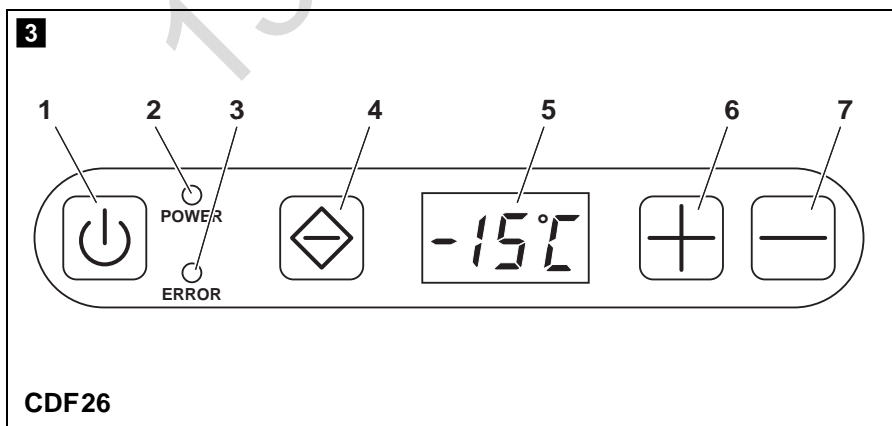
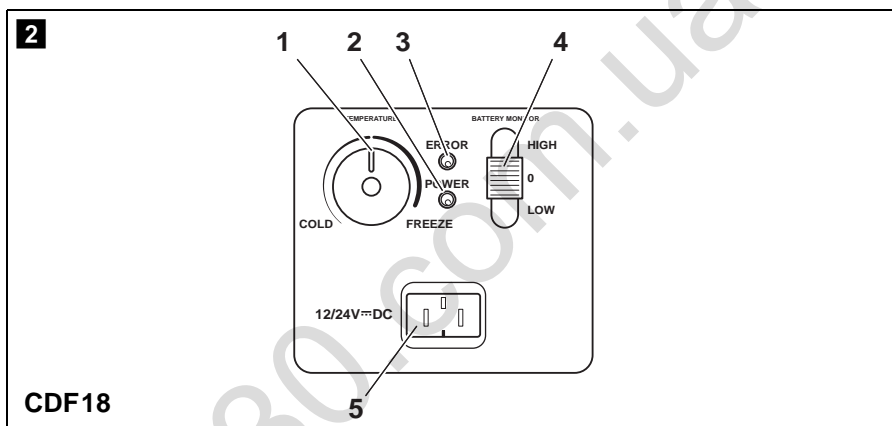
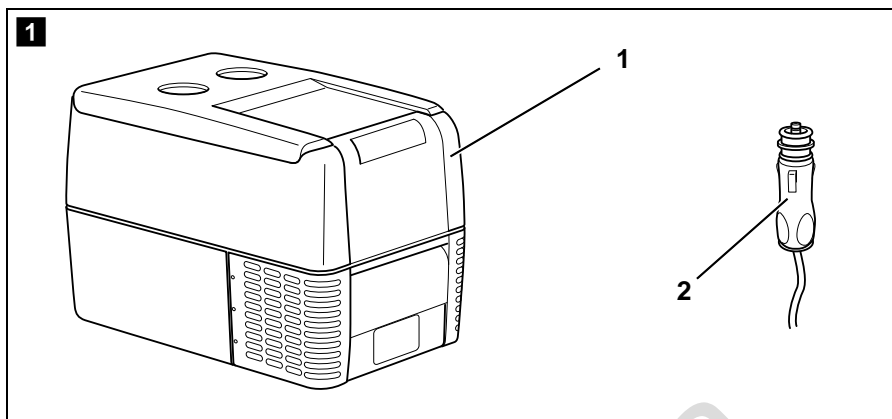

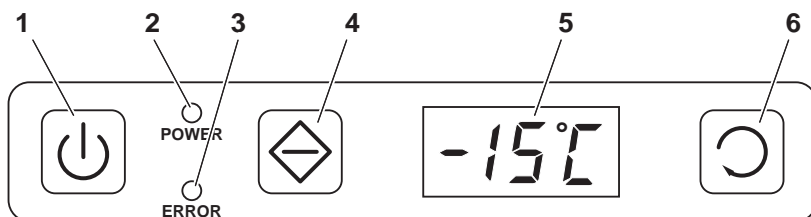
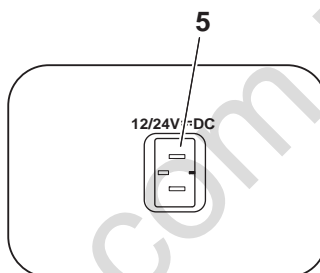
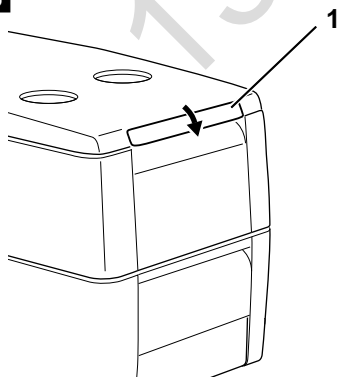
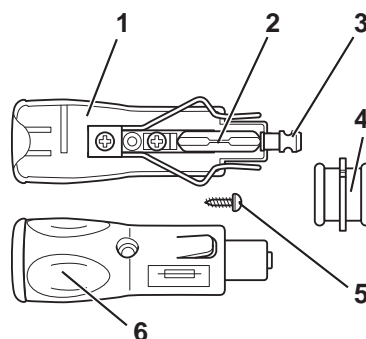
4**CDF36, CDF46****5****CDF26, CDF36, CDF46****6****7**

8

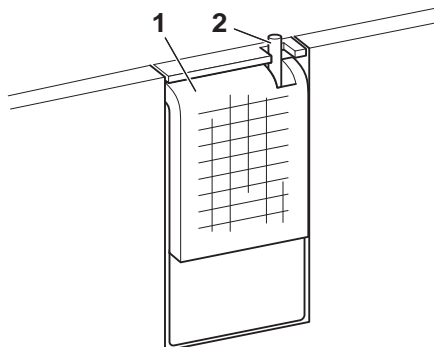

CDF26, CDF36, CDF46

130.com.ua

Please read this operating manual carefully before starting the device. Keep it in a safe place for future reference. If the device is passed on to another person, this operating manual must be handed over to the user along with it.

The manufacturer cannot be held liable for damage resulting from **improper usage** or **incorrect operation**.

Contents

1	Explanation of symbols	24
2	Safety instructions	25
3	Scope of delivery	27
4	Intended use	28
5	Function description	28
6	Operation	31
7	Cleaning and maintenance	38
8	Guarantee	38
9	Troubleshooting	39
10	Disposal	39
11	Technical data	40

1 Explanation of symbols



DANGER!

Safety instruction: Failure to observe this instruction will cause fatal or serious injury.



WARNING!

Safety instruction: Failure to observe this instruction can cause fatal or serious injury.

**CAUTION!**

Safety instruction: Failure to observe this instruction can lead to injury.

**NOTICE!**

Failure to observe this instruction can cause material damage and impair the function of the product.

**NOTE**

Supplementary information for operating the product.

- ▶ **Action:** This symbol indicates that action is required on your part. The required action is described step-by-step.
- ✓ This symbol describes the result of an action.

Fig. 1 5, page 3: This refers to an element in an illustration. In this case, item 5 in figure 1 on page 3.

2 Safety instructions

2.1 General safety

**WARNING!**

- Do not operate the device if it is visibly damaged.
- If this device's power cable is damaged, it must be replaced by the manufacturer, customer service or a similarly qualified person in order to prevent safety hazards.
- This device may only be repaired by qualified personnel. Improper repairs can lead to considerable hazards.
- This device can be used by children aged 8 years or over, as well as by persons with diminished physical, sensory or mental capacities or a lack of experience and/or knowledge, providing they are supervised or have been taught how to use the device safely and are aware of the resulting risks.
- Cleaning and user maintenance must not be carried out by children without supervision.
- Children must not play with the device.

- Children must be supervised to ensure that they do not play with the device.
- Always keep and use the device out of the reach of children under the age of 8 years.
- Do not store any explosive substances such as spray cans with a flammable propellant in the device.

**CAUTION!**

- Disconnect the device from the mains
 - before each cleaning and maintenance
 - after every use
- Food may only be stored in its original packaging or in suitable containers.

**NOTICE!**

- Check that the voltage specification on the type plate corresponds to that of the energy supply.
- Only connect the device to a DC plug socket in the vehicle (e. g. cigarette lighter) with the DC cable.
- Never pull the plug out of the socket by the cable.
- Disconnect the cooler and other power consuming devices from the battery before connecting the quick charging device.
- Disconnect the cooler or switch it off when you turn off the engine. Otherwise you may discharge the battery.
- The cooling device is not suitable for transporting caustic materials or materials containing solvents.

2.2 Operating the device safely

**DANGER!**

- Do not touch exposed cables with your bare hands.

**CAUTION!**

- Before starting the device, ensure that the power supply line and the plug are dry.

**NOTICE!**

- Do not use electrical devices inside the cooler unless they are recommended by the manufacturer for the purpose.

- Do not place the device near naked flames or other heat sources (heaters, direct sunlight, gas ovens etc.).
- **Danger of overheating!**
Ensure at all times that there is sufficient ventilation so that the heat that arises during operation does not build up. Make sure that the device is sufficiently far away from walls and other objects so that the air can circulate.
- Ensure that the ventilation openings are not covered.
- Do not fill the inner container with ice or fluid.
- Never immerse the device in water.
- Protect the device and the cable against heat and moisture.

3 Scope of delivery

fig. 1, page 3, shows the scope of delivery.

Item	Quantity	Description
1	1	Cooler
2	1	Connection cable for 12/24 V \Rightarrow connection
–	1	Operating manual

3.1 Accessories

To operate the device at the AC mains supply, we recommend using one of the following WAECO rectifiers.

Available as accessory (not included in scope of delivery):

- 220–240 V: CoolPower EPS100
- 110–240 V: CoolPower MPS35

4 Intended use



The cooler is suitable for cooling and freezing foods. The device is also suitable for use on boats.

The device is designed to be operated from a 12 V DC or 24 V DC on-board supply socket of a vehicle (e. g. cigarette lighter), boat or caravan.



NOTE

To operate the device at the AC mains supply, we recommend using one of the following WAECO rectifiers:

- 220–240 V: CoolPower EPS100
- 110–240 V: CoolPower MPS35



CAUTION! Health hazard!

Please check if the cooling capacity of the device is suitable for storing the food or medicine you wish to cool.

5 Function description

The cooler can chill products, keep them cool as well as freeze them. A maintenance-free, CFC-free refrigerant circuit with compressor provides the cooling. The extra strong CFC-free insulation and powerful compressor ensure especially fast cooling.

The cooler is designed for mobile use.

When used on boats, the cooler can be withstand a constant heel (inclination) of 30°.



An integrated dual-stage (CDF 18) / three-stage (CDF 26, CDF 36, CDF 46) battery monitor prevents your vehicle battery from excessive discharging.

5.1 Operating and display elements

CDF18

Operating panel and connection socket (fig. **2**, page 3):

Item	Description	Explanation
1	TEMPERATURE	Temperature controller, cooling temperature at the end positions:
		COLD: +10 °C
		FREEZE: -18 °C
2	POWER	Operating display
		LED is lit green: Device is switched on and ready for operation
		LED is lit yellow: Set temperature has been reached
3	ERROR	LED flashes red: Switched on device is not ready for operation
4	BATTERY MONITOR	Switch-on device/battery monitor:
		0: Device is switched off
		HIGH: Device is switched on, bat- tery monitor is in HIGH mode
		LOW: Device is switched on, bat- tery monitor is in LOW mode
5	12/24V DC	Connection socket DC voltage supply

CDF26

Operating panel and connection socket (fig. **3**, page 3, fig. **5**, page 4):

Item	Description	Explanation
1	ON OFF button	Switches the cooler on or off when the button is pressed for between one and two seconds
2	POWER	Status indication LED lights up green: Compressor is on LED lights up orange: Compressor is off LED flashes orange: Display switched off automatically due to low battery voltage
3	ERROR	LED flashes red: Device is switched on but not ready for operation
4	SET	Selects the input mode – Temperature setting – Celsius or Fahrenheit display – Set battery monitor
5	–	Display, shows the information The first three digits of the four-digit display show the temperature, the fourth digit shows the temperature unit (°C or °F).
6	UP +	Press once to increase the value
7	DOWN –	Press once to decrease the value

CDF36, CDF46

Operating panel and connection socket (fig. **3**, page 3, fig. **5**, page 4):

Item	Description	Explanation
1	ON OFF button	Switches the cooler on or off when the button is pressed for between one and two seconds
2	POWER	Status indication LED lights up green: Compressor is on LED lights up orange: Compressor is off LED flashes orange: Display switched off automatically due to low battery voltage
3	ERROR	LED flashes red: Device is switched on but not ready for operation
4	SET	Selects the input mode – Temperature setting – Celsius or Fahrenheit display – Set battery monitor
5	–	Display, shows the information The first three digits of the four-digit display show the temperature, the fourth digit shows the temperature unit (°C or °F).
6	ADJUST	Press once to increase the value Press once to decrease the value

6 Operation

6.1 Before initial use



NOTE

Before starting your new cooler for the first time, you should clean it inside and outside with a damp cloth for hygienic reasons (please also refer to the chapter “Cleaning and maintenance” on page 38).

6.2 Energy saving tips

- Choose a well ventilated installation location which is protected against direct sunlight.
- Allow warm food to cool down first before placing it in the device to keep cool.
- Do not open the cooling device more often than necessary.
- Do not leave the cooler unit open for longer than necessary.
- Defrost the cooler once a layer of ice forms.
- Avoid unnecessary low temperatures.

6.3 Connecting the cooler

The cooler can be operated with 12 V or 24 V DC.



NOTICE! Danger of damaging the device!

Disconnect the cooler and other consumer units from the battery before you connect the battery to a quick charging device. Overvoltage can damage the electronics of the device.

For safety reasons the cooler is equipped with an electronic system to prevent the polarity reversal. This protects the cooler against short-circuiting when connecting to a battery.

- Plug the 12/24-V connection cable (fig. **1** 2, page 3) into the DC voltage socket and also into the cigarette lighter or a 12 V or 24 V socket.

6.4 Using the battery monitor

If the cooler is operated when the vehicle ignition is switched off, the cooler switches off automatically as soon as the supply voltage falls below a set level. The cooler will switch back on once the battery has been recharged to the restart voltage level.



NOTICE! Danger of damage!

When switched off by the battery monitor, the battery will no longer be fully charged. Avoid starting repeatedly or operating current consumers without longer charging phases. Ensure that the battery is recharged.

In “HIGH” mode, the battery monitor responds faster than at the levels “LOW” and “MED” (see the following table).

CDF 18:

Battery monitor mode	LOW	HIGH
Switch-off voltage at 12 V	10,2 V ± 0,3 V	11,2 V ± 0,3 V
Restart voltage at 12 V	11,2 V ± 0,3 V	12,2 V ± 0,3 V
Switch-off voltage at 24 V	22,0 V ± 0,3 V	23,9 V ± 0,3 V
Restart voltage at 24 V	23,3 V ± 0,3 V	25,1 V ± 0,3 V

CDF 26, CDF 36, CDF 46:

Battery monitor mode	LOW	MED	HIGH
Switch-off voltage at 12 V	10,1 V	11,4 V	11,8 V
Restart voltage at 12 V	11,1 V	12,2 V	12,6 V
Switch-off voltage at 24 V	21,5 V	24,1 V	24,6 V
Restart voltage at 24 V	23,0 V	25,3 V	26,2 V

**NOTE**

When the cooler is supplied by the starter battery, select the battery monitor mode "HIGH". If the cooler is connected to a supply battery, the battery monitor mode "LOW" will suffice.
If you wish to operate the cooler from the AC mains, set the battery monitor to the "LOW" position.

CDF 26: Setting the battery monitor mode

This is how to select the battery monitor mode:

- Switch on the cooler.
- Press the "SET" button three times.
- Use the "+" and "-" buttons to select the battery monitor mode.
- ✓ The selected mode then appears in the display for a few seconds. The display flashes several times before it returns to the current temperature.

CDF36, CDF46: Setting the battery monitor mode

This is how to select the battery monitor mode:

- Switch on the cooler.
- Press the “SET” button three times.
- Use the “ADJUST” button to select the battery monitor mode.

6.5 Using the cooler



NOTICE! Danger of overheating!

Ensure at all times that there is sufficient ventilation so that the heat that generated during operation can dissipate. Ensure that the ventilation slots are not covered. Make sure that the device is sufficiently far away from walls and other objects so that the air can circulate.

- Place the cooler on a firm foundation. Make sure that the ventilation slots are not covered and that the heated air can dissipate.
- Close the cooler, see chapter “Connecting the cooler” on page 32.



NOTICE! Danger from excessively low temperature!

Ensure that the only those objects are placed in the cooler that are intended to be cooled at the selected temperature.

Locking the cooler

- Close the lid.
- Press the lock (fig. **6** 1, page 4) down, until it latches in place audibly.

CDF18: Switching on the cooler

- Slide the sliding switch “BATTERY MONITOR” to HIGH if you wish to operate from a starter battery or to “LOW” if you want to operate from a supply battery.



NOTE

If you wish to operate the cooler from the AC mains, set the battery monitor to the “LOW” position.

- ✓ The “POWER” LED is lit green.

- ✓ The cooler starts cooling the interior.
- Set the cooling temperature with the temperature controller “TEMPERATURE”.
- ✓ When the cooling temperature has been reached, the “POWER” LED is lit yellow.

CDF26, CDF36, CDF46: Switching on the cooler

- Press the “ON/OFF” button for three seconds.
- ✓ The “POWER” LED is lit green.
- ✓ The display switches on and shows the current cooling temperature.
- ✓ The cooler starts cooling the interior.



NOTE

If you wish to operate the cooler from the AC mains, set the battery monitor to the “LOW” position.

CDF18: Switching off the cooler

- Empty the cooler.
- To Switch the cooler off: Slide the sliding switch “BATTERY MONITOR” to “0”:
- Pull out the connection cable.

If you do not want to use the cooler for a longer period of time:

- Leave the cover slightly open. This prevents odour build-up.

CDF26, CDF36, CDF46: Switching off the cooler

- Empty the cooler.
- Switch the cooler off.
- Unplug the connection cable.

If you do not want to use the cooler for a longer period of time:

- Leave the lid slightly open. This prevents build-up of odours.

6.6 Setting the temperature

CDF26:

- Press the “SET” button once.
- Use the “+” and “-” buttons to set the cooling temperature.
- ✓ The set cooling temperature then appears in the display for a few seconds. The display flashes several times before it returns to the current temperature.

CDF36, CDF46:

- Press the “SET” button once.
- Use the “ADJUST” button to set the cooling temperature.

The set cooling temperature then appears in the display for a few seconds. The display flashes several times before it returns to the current temperature.

6.7 Selecting the temperature unit

CDF26:

You can switch the temperature display between Celsius and Fahrenheit. To do this, proceed as follows:

- Switch on the cooler.
- Press the “SET” button twice.
- Use the “+” and “-” buttons to set the cooling temperature.
- ✓ The set temperature unit then appears in the display for a few seconds. The display flashes several times before it returns to the current temperature.

CDF36, CDF46:

You can switch the temperature display between Celsius and Fahrenheit. To do this, proceed as follows:

- Switch on the cooler.
- Press the “SET” button twice.
- Use the “ADJUST” button to set the Celsius or Fahrenheit temperature unit.

6.8 Defrosting the cooler

Humidity can form frost in the interior of the cooling device or on the vaporiser. This reduces the cooling capacity. Defrost the device in good time to avoid this.



NOTICE! Danger of damaging the device!

Never use hard or pointed tools to remove ice or to loosen objects which have frozen in place.

To defrost the cooler, proceed as follows:

- Take out the contents of the cooling device.
- If necessary, place them in another cooling device to keep them cool.
- Switch off the device.
- Leave the cover open.
- Wipe off the defrosted water.

6.9 Replacing the plug fuse (12/24 V)

- Pull the adapter sleeve (fig. **7** 4, page 4) off of the plug.
- Unscrew the screw (fig. **7** 5, page 4) out of the upper half of the housing (fig. **7** 1, page 4).
- Carefully raise the upper half of the housing from the lower (fig. **7** 6, page 4) half.
- Take out the contact pin (fig. **7** 3, page 4).
- Replace the defective fuse (fig. **7** 2, page 4) with a new one that has the same rating (8A 32V).
- Re-assemble the plug in the reverse order.

6.10 Replacing the light bulb (CDF26, CDF36, CDF46)

- Press the switch pin (fig. **8** 2, page 5) downwards so that the transparent part (fig. **8** 1, page 5) of the lamp can be removed at the front.
- Replace the light bulb.
- Press the lamp back into the housing.

7 Cleaning and maintenance

**WARNING!**

Always disconnect the device from the mains before you clean and service it.

**NOTICE! Risk of damage**

- Never clean the cooler under running water or in dish water.
- Do not use abrasive cleaning agents or hard objects during cleaning as these can damage the cooler.

- Occasionally clean the device interior and exterior with a damp cloth.
- Make sure that the air inlet and outlet vents on the device are free of any dust and dirt, so that heat can be released and the device is not damaged.

8 Guarantee

The statutory warranty period applies. If the product is defective, please contact the manufacturer's branch in your country (see the back of the instruction manual for the addresses) or your retailer.

For repair and guarantee processing, please include the following documents when you send in the device:

- A copy of the receipt with purchasing date
- A reason for the claim or description of the fault

9 Troubleshooting

Fault	Possible cause	Suggested remedy
Device does not function, LED does not glow.	There is no voltage present in the 12/24 V socket (cigarette lighter) in your vehicle.	The ignition must be switched on in most vehicles to apply current to the cigarette lighter.
	No voltage present in the AC voltage socket.	Try using another plug socket.
The device does not cool (plug is inserted, "POWER" LED is lit).	Defective compressor.	This can only be repaired by an authorised customer services unit.
The device does not cool (plug is inserted, "ERROR" LED flashes).	Battery voltage is too low.	Test the battery and charge it as needed.
When operating from the 12/24-V socket (cigarette lighter): The ignition is on and the device is not working and the LED is not lit. Pull the plug out of the socket and make the following checks.	The cigarette lighter socket is dirty. This results in a poor electrical contact.	If the plug of your cooler becomes very warm in the cigarette lighter socket, either the lighter socket must be cleaned or the plug has not been assembled correctly.
	The fuse of the 12/24 V plug has blown.	Replace the fuse (5 A) in the cigarette lighter plug, see chapter "Replacing the plug fuse (12/24 V)" on page 37.
	The vehicle fuse has blown.	Replace the vehicle's 12/24 V socket fuse (usually 15 A). Please refer to your vehicle's operating manual.
"ERROR" LED flashes for longer than 2 minutes, as follows: 3 flashes, pause, 3 flashes, pause, ...	Device is defective.	This can only be repaired by an authorised customer services unit.



10 Disposal

- Place the packaging material in the appropriate recycling waste bins wherever possible.



If you wish to finally dispose of the product, ask your local recycling centre or specialist dealer for details about how to do this in accordance with the applicable disposal regulations.

11 Technical data

	WAECO CoolFreeze			
	CDF18	CDF26	CDF36	CDF46
Art.-Nr.:	9105100002	9105303457	9105303458	9105303459
Overall capacity:	18 l	21 l	31 l	39 l
Connection voltage:	12/24 V $\overline{=}$			
Rated current:				
– 12 V $\overline{=}$:	4.0 A \pm 0.5	5.0 A \pm 0.5	5.0 A \pm 0.5	5.0 A \pm 0.5
– 24 V $\overline{=}$:	1.7 A \pm 0.5	2.5 A \pm 0.5	2.5 A \pm 0.5	2.5 A \pm 0.5
Cooling capacity:	+10 °C to –18 °C		+10 °C to –15 °C	
Dimensions (W x H x D) in mm:	456 x 414 x 300	550 x 425 x 260	560 x 380 x 340	560 x 475 x 340
Weight:	11.5 kg	12.7 kg	12.4 kg	13.7 kg
Test/certificates:	  			



NOTE

At ambient temperatures above 32 °C (90 °F) the minimum temperature cannot be achieved.

The coolant circuit contains R134a.