



### PHONES

(044) 360-7-130  
 (050) 336-0-130  
 (063) 788-0-130  
 (067) 233-0-130  
 (068) 282-0-130

# 130 Internet store of autogoods

COM.UA



ICQ  
 294-0-130  
 597-0-130

SKYPE  
 km-130

CAR RECEIVERS — Receivers • Media receivers and stations • Native receivers • CD/DVD changers • FM-modulators/USB adapters • Flash memory • Facia plates and adapters • Antennas • Accessories |  
 CAR AUDIO — Car audio speakers • Amplifiers • Subwoofers • Processors • Crossovers • Headphones • Accessories | TRIP COMPUTERS — Universal computers • Model computers • Accessories |  
 GPS NAVIGATORS — Portable GPS • Built-in GPS • GPS modules • GPS trackers • Antennas for GPS navigators • Accessories | VIDEO — DVR • TV sets and monitors • Car TV tuners • Cameras • Videomodules  
 • Transcoders • Car TV antennas • Accessories | SECURITY SYSTEMS — Car alarms • Bike alarms • Mechanical blockers • Immobilizers • Sensors • Accessories | OPTIC AND LIGHT — Xenon • Bixenon • Lamps  
 • LED • Stroboscopes • Optic and Headlights • Washers • Light, rain sensors • Accessories | PARKTRONICS AND MIRRORS — Rear parktronic • Front parktronic • Combined parktronic • Rear-view mirrors  
 • Accessories | HEATING AND COOLING — Seat heaters • Mirrors heaters • Screen-wipers heaters • Engine heaters • Auto-refrigerators • Air conditioning units • Accessories | TUNING — Vibro-isolation  
 • Noise-isolation • Tint films • Accessories | ACCESSORIES — Radar-detectors • Handsfree, Bluetooth • Windowlifters • Compressors • Beeps, loudspeakers • Measuring instruments • Cleaners • Car seats  
 • Miscellaneous | MOUNTING — Installation kits • Upholstery • Grilles • Tubes • Cable and wire • Tools • Miscellaneous | POWER — Batteries • Converters • Start-charging equipment • Capacitors  
 • Accessories | MARINE AUDIO AND ELECTRONICS — Marine receivers • Marine audio speakers • Marine subwoofers • Marine amplifiers • Accessories | CAR CARE PRODUCTS — Additives • Washer fluid •  
 Care accessories • Car polish • Flavors • Adhesives and sealants | LIQUID AND OIL — Motor oil • Transmission oil • Brake fluid • Antifreeze • Technical lubricant



In store "130" you can find and buy almost all necessary goods for your auto in Kyiv and other cities, delivery by ground and postal services. Our experienced consultants will provide you with exhaustive information and help you to chose the very particular thing. We are waiting for you at the address

<http://130.com.ua>

CE FC ISO/TS 16949:2002

# ELECTRIC POWER WINDOW

High technology & superior quality

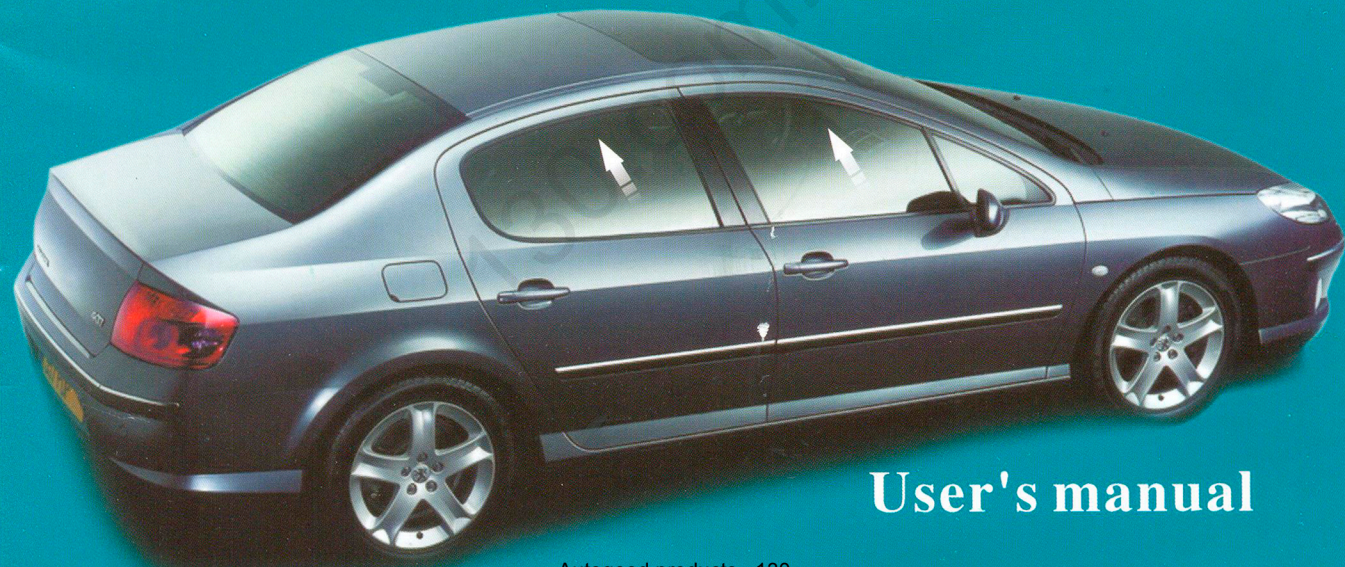

User's manual



## ELECTRIC WINDOWS REGULATOR

**NOTE:** Before proceeding with the installation, follow carefully the instructions. The installation should only be competent for the experienced staff.

- Our product has been conceived following using standard; but we can sum up the following necessary installation conditions, that can be used for most of the vehicle.  
Remove the door handle and door trim; check if our mechanism can be inserted inside (see point 2 of the installation instructions).
- After removed the door handle ensure there is at least 12mm of the window shaft extending beyond the level of the door skin. If not, follow carefully the installation instructions in order to find a possible solution.
- The maximum power of our mechanism is to withstand 3kg. Applied for 70mm distance from the center. This power is enough for most of vehicle. If you have any doubts or the vehicle has a particular heavy control, we advise you to check the weight.
- Before fitting, please check that the mechanical door parts function is correct, if necessary, grease the channels or replace the faulty parts. Please also note that if the manual device is noisy. It will be necessary to eliminate the noise before commencing installation as the noise will increase with the electric device.



- Lower the window
- Remove the window handle
- Apply on the panel of the adhesive template for the center of the pivot as shown in the picture
- Remove the door panel
- Detach carefully the outside protective cover

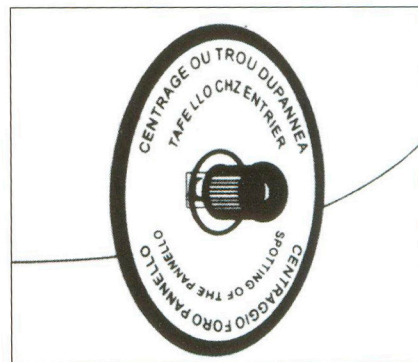
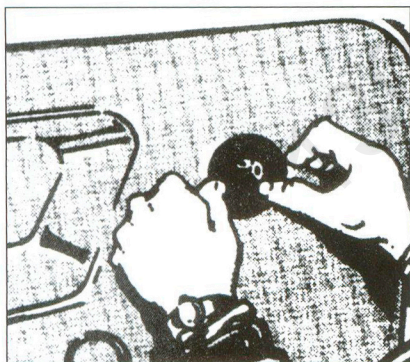
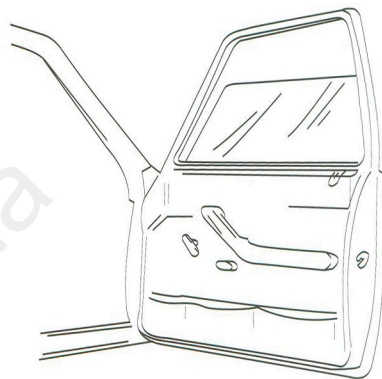



- Find the assembling position of the driving gear.
- Check which driving gear (there are two driving gears which are symmetric), is more suitable for the door.
- The reducer will be placed outside the panel
- During the positioning, you may require some adapters on the door in order to obtain the minimum protrusion of the reducer from the panel (see point A).
- During the fixing of the reducer or of the motor, you may require to supply the mounting bracket.

POINT A  
POINT A  
PUNKT A  
PARTICOLARE A  
DIBUJO A

DOOR METAL SHEET  
PANNEAU METALLIQUE  
TÜRINNENBLECH  
LAMIERA PORTA  
PANEL DE ALAMBRE

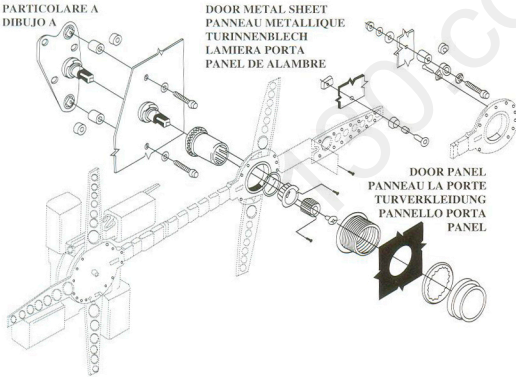

DOOR PANEL  
PANNEAU LA PORTE  
TÜRVERKLEIDUNG  
PANNELLO PORTA  
PANEL

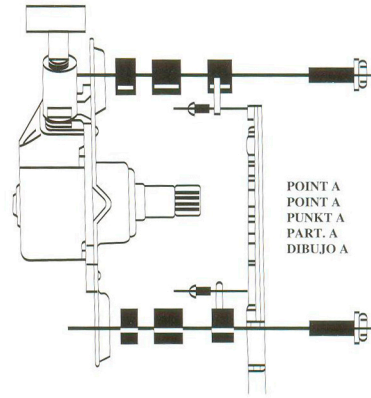
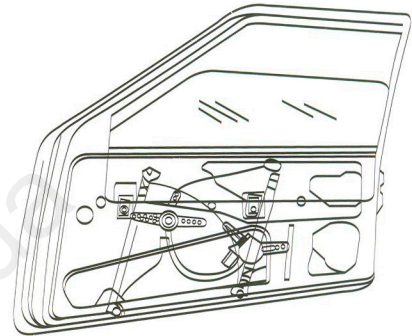

POINT A  
POINT A  
PUNKT A  
PART. A  
DIBUJO A



Choose the correct adapter of following table to mount it on the handle pivot.  
In case the handle is fixed with the screw, using the screw again to fix the adapter.  
Choose the gear sleeve according to the following table.  
Mount it on the reducer and fix it with the supplied grommet in the kit N. 1.

## ADAPTERS TABLE

N. 1: ALFA ROMEO / AUTOBIANCHI BEDFORD / DAF / DATSUN FIAT / FORD (CEE) / LANCIA MERCEDES / NISSAN / OPEL PORSCHE / SAAB / SUBARU VOLKSWAGEN	4: AUSTIN / ROVER  N. 5: VAUXALL / JAGUAR BEDFORD / ROVER  N. 6: FORD (UK)  N. 7: OPEL  N. 8: DAIHATSU / MITSUBISHI TOYOTA / SUZUKI / G. M CHEVROLET / PONTIAC	N. 9: HONDA  N. 10: MAZDA / FORD (U.S.A.)  N. 11: ISUZU  N. 12: FORD (U.S.A.)  N. 13: DODGE / CHRISLER
---	---	---

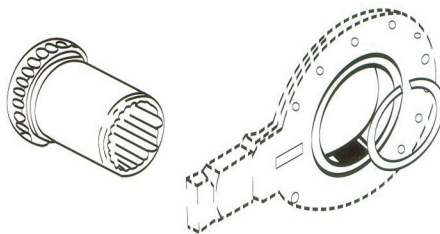
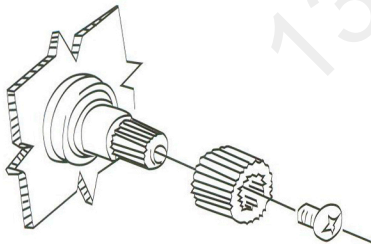



Find the right position on the door where to fix the motor.

**NOTE:** You must locate and fix first the motor, then insert the gear sleeve into the handle pivot.

- If necessary it is possible to change the position to remove the screws, rotate the motor as shown in the picture and screw it to the required position.
- Insert the reducer with the gear sleeve so that the two cavities coincide and fix with the supplied screws in the kit N.1
- Before mounting the gear sleeve, check the function of the emergency door handle.
- Then mount the middle gear sleeve so that the two cavities coincide and fix with the supplied screws in the kit N.1.

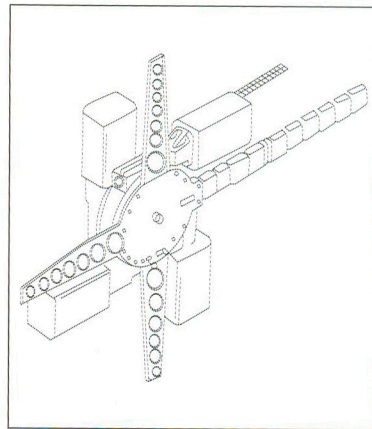
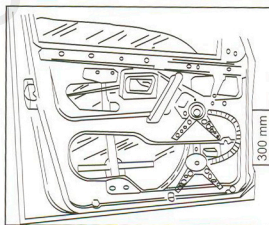
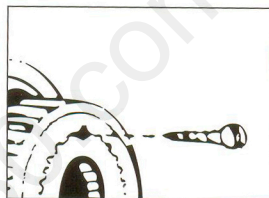
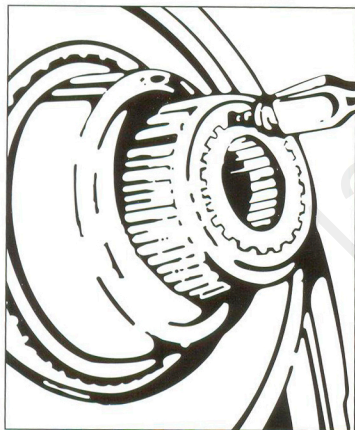



**Mounting the grommet on the inside panel.**

**If necessary, widen the hole in the panel.**

**Choose the appropriate grommet, insert it into the door casing and fix with the retainer ring.**

**Choose the most appropriate cap (the lowest) and mount it on the grommet.**

**Fix the cap on the grommet and fit the panel on the door.**

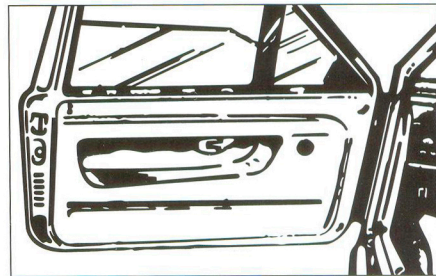
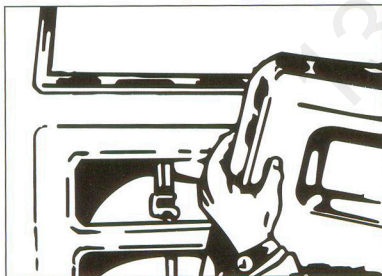
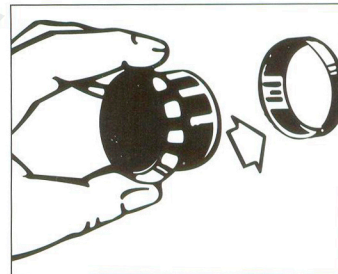
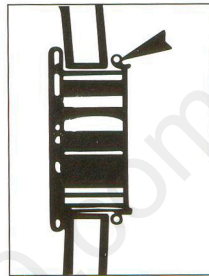
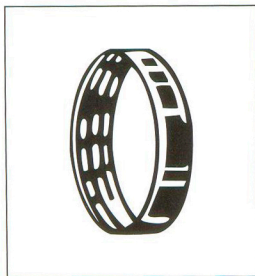



<b>DESCRIPTION</b>	<b>QTY</b>	<b>MARK</b>
<b>1 ELECTRIC WINDOW L</b>	<b>1</b>	
<b>1 ELECTRIC WINDOW R</b>	<b>1</b>	
<b>2 CAPS</b>	<b>2</b>	
<b>3 CIRCLIP</b>	<b>2</b>	
<b>4 RETAINER RING</b>	<b>2</b>	
<b>5 SPEED NUT</b>	<b>4</b>	
<b>6 SPACERS</b>	<b>1</b>	
<b>7 ADAPTORS</b>	<b>2</b>	
<b>8 GEARS</b>	<b>2</b>	
<b>9 BRACKET</b>	<b>8</b>	
<b>10 RUBBER BUSH</b>	<b>8</b>	
<b>11 METAL BUSH</b>	<b>8</b>	
<b>12 SCREW 4X16</b>	<b>20</b>	
<b>13 SCREW 3X5</b>	<b>22</b>	

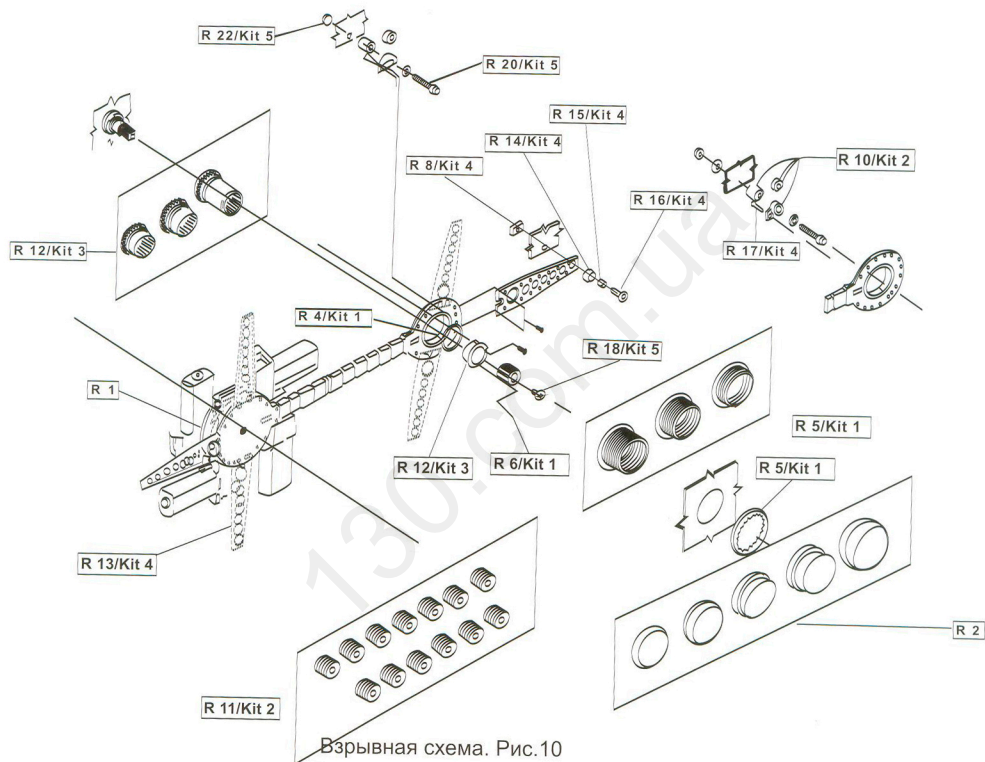

Взрывная схема. Рис.10