



PHONES

0 (800) 800 130  
(050) 462 0 130  
(063) 462 0 130  
(067) 462 0 130

**130**  
COM.UA

Internet store of  
**autogoods**



SKYPE

km-130

CAR RECEIVERS — Receivers • Media receivers and stations • Native receivers • CD/DVD changers • FM-modulators/USB adapters • Flash memory • Facia plates and adapters • Antennas • Accessories |  
CAR AUDIO — Car audio speakers • Amplifiers • Subwoofers • Processors • Crossovers • Headphones • Accessories | TRIP COMPUTERS — Universal computers • Model computers • Accessories |  
GPS NAVIGATORS — Portable GPS • Built-in GPS • GPS modules • GPS trackers • Antennas for GPS navigators • Accessories | VIDEO — DVR • TV sets and monitors • Car TV tuners • Cameras • Videomodules  
• Transcoders • Car TV antennas • Accessories | SECURITY SYSTEMS — Car alarms • Bike alarms • Mechanical blockers • Immobilizers • Sensors • Accessories | OPTIC AND LIGHT — Xenon • Bixenon • Lamps  
• LED • Stroboscopes • Optic and Headlights • Washers • Light, rain sensors • Accessories | PARKTRONICS AND MIRRORS — Rear parktronic • Front parktronic • Combined parktronic • Rear-view mirrors  
• Accessories | HEATING AND COOLING — Seat heaters • Mirrors heaters • Screen-wipers heaters • Engine heaters • Auto-refrigerators • Air conditioning units • Accessories | TUNING — Vibro-isolation  
• Noise-isolation • Tint films • Accessories | ACCESSORIES — Radar-detectors • Handsfree, Bluetooth • Windowlifters • Compressors • Beeps, loudspeakers • Measuring instruments • Cleaners • Car seats  
• Miscellaneous | MOUNTING — Installation kits • Upholstery • Grilles • Tubes • Cable and wire • Tools • Miscellaneous | POWER — Batteries • Converters • Start-charging equipment • Capacitors  
• Accessories | MARINE AUDIO AND ELECTRONICS — Marine receivers • Marine audio speakers • Marine subwoofers • Marine amplifiers • Accessories | CAR CARE PRODUCTS — Additives • Washer fluid •  
Care accessories • Car polish • Flavors • Adhesives and sealants | LIQUID AND OIL — Motor oil • Transmission oil • Brake fluid • Antifreeze • Technical lubricant



In store "130" you can find and buy almost all necessary goods for your auto in Kyiv and other cities, delivery by ground and postal services. Our experienced consultants will provide you with exhaustive information and help you to choose the very particular thing. We are waiting for you at the address

<https://130.com.ua>

## LIMITED WARRANTY STATEMENT

Rockford Corporation offers a limited warranty on Rockford Fosgate products on the following terms:

### Length of Warranty

**Speakers – 1 Year. Any Factory Refurbished Product – 90 days (receipt required)**

### What is Covered

This warranty applies only to Rockford Fosgate products sold to consumers by Authorized Rockford Fosgate Dealers in the United States of America or its possessions. Product purchased by consumers from an Authorized Rockford Fosgate Dealer in another country are covered only by that country's Distributor and not by Rockford Corporation.

### Who is Covered

This warranty covers only the original purchaser of Rockford product purchased from an Authorized Rockford Fosgate Dealer in the United States. In order to receive service, the purchaser must provide Rockford with a copy of the receipt stating the customer name, dealer name, product purchased and date of purchase. Products found to be defective during the warranty period will be repaired or replaced (with a product deemed to be equivalent) at Rockford's discretion.

### What is Not Covered

1. Damage caused by accident, abuse, improper operations, water, theft, shipping
2. Any cost or expense related to the removal or reinstallation of product
3. Service performed by anyone other than Rockford or an Authorized Rockford Fosgate Service Center
4. Any product which has had the serial number defaced, altered, or removed
5. Subsequent damage to other components
6. Any product purchased outside the U.S.
7. Any product not purchased from an Authorized Rockford Fosgate Dealer

### Limit on Implied Warranties

Any implied warranties including warranties of fitness for use and merchantability are limited in duration to the period of the express warranty set forth above. Some states do not allow limitations on the length of an implied warranty, so this limitation may not apply. No person is authorized to assume for Rockford Fosgate any other liability in connection with the sale of the product.

### How to Obtain Service

Contact the Authorized Rockford Fosgate Dealer you purchased this product from. If you need further assistance, call 1-800-669-9899 for Rockford Customer Service. You must obtain an **RA# (Return Authorization number)** to return any product to Rockford Fosgate. You are responsible for shipment of product to Rockford.

### EU Warranty

This product meets the current EU warranty requirements, see your Authorized dealer for details.



**Rockford Fosgate**  
Rockford Corporation  
600 South Rockford Drive  
Tempe, Arizona 85281 U.S.A.

In U.S.A., (480) 967-3565 - Customer Service 1-800-669-9899

[www.rockfordfosgate.com](http://www.rockfordfosgate.com)

Designed and Engineered by Rockford Fosgate, Tempe, AZ, USA.

© 2010 Rockford Corporation. All rights reserved.

Rockford Fosgate and the Rockford Fosgate logo are either registered trademarks or trademarks of Rockford Corporation.

05/2009 B.M.

11/2009 E.R. (WebWizard)

1230-56187-01

Printed in China



# POWERR

## Component Systems

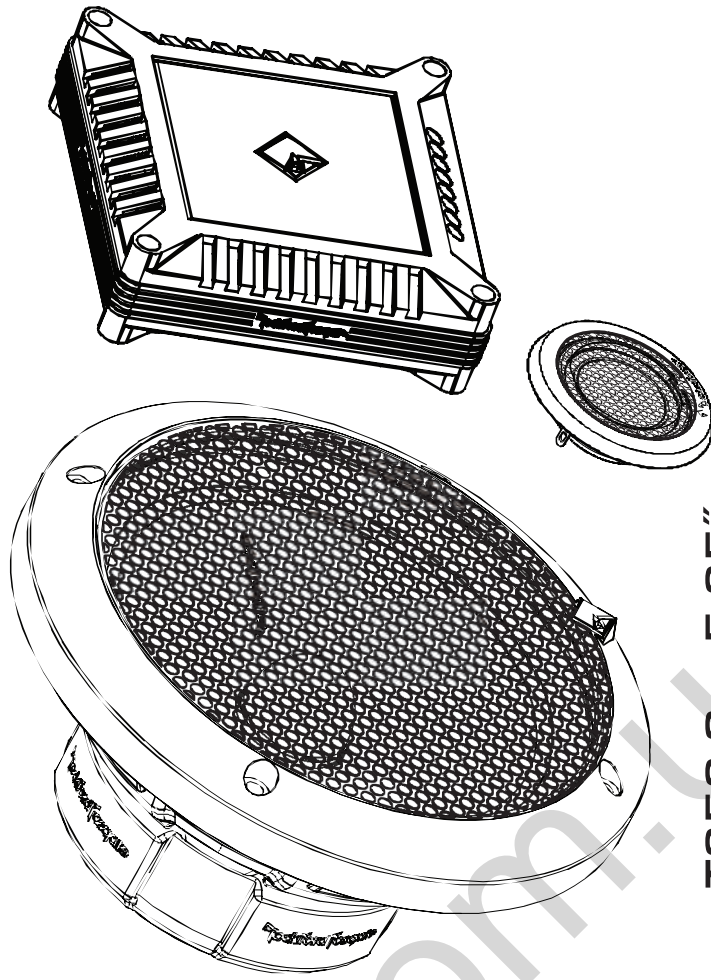

**T252-S – 5.25"**

**T2652-S – 6.5"**

**T2T-S – Tweeter System**

**Installation & Operation**  
Installation et fonctionnement  
Instalación y funcionamiento  
Einbau und Betrieb  
Installazione e funzionamento

Date of Purchase: \_\_\_\_\_

Serial Number: \_\_\_\_\_

## SAFETY

**CAUTION:** Before installation, disconnect the battery negative (-) terminal to prevent damage to the unit, fire and/or possible injury.

## PRACTICE SAFE SOUND™

Continuous exposure to sound pressure levels over 100dB may cause permanent hearing loss. High powered auto sound systems may produce sound pressure levels well over 130dB. Use common sense and practice safe sound.

## CARTON CONTENTS

- (1) Set T2 Series Speakers with Tweeters and 2-Way Crossover or (1) Set T2 Series Tweeters with HP Crossover
- (1) Set of grilles/trim rings
- (2) Sets of tweeter trim rings:
  - (1 set of polished aluminum)
  - (1 set of brushed aluminum)
- Tweeter Mounting Hardware with Surface, Angle, and Flush Mounts
- (1) Set Adapter Plates: T252-S (5"x7"/6"x9"), T2652-S (5"x7"/6"x9")

## INSTALLATION CONSIDERATIONS

Before beginning any installation, follow these simple rules:

1. Be sure to carefully read and understand the instructions before attempting to install these speakers.
2. For safety, disconnect the negative lead from the battery prior to beginning the installation.
3. For easier assembly, we suggest you run all wires prior to mounting your speakers in place.
4. Use high quality connectors for a reliable installation and to minimize signal or power loss.
5. **Think before you drill!** Be careful not to cut or drill into gas tanks, fuel lines, brake or hydraulic lines, vacuum lines or electrical wiring when working on any vehicle. If installation in a boat, take care not to cut or drill through the main hull.
6. Never run wires underneath the vehicle. Running the wires inside the vehicle or hull area provides the best protection.
7. Avoid running wires over or through sharp edges. Use rubber or plastic grommets to protect any wires routed through metal, especially the firewall.

## MOUNTING

1. Determine where the speakers will be mounted. Ensure an area large enough for the speaker to mount evenly. Be sure that the mounting location is deep enough for the speaker to fit; if mounting in a door, operate all functions (windows, locks, etc.) through their entire operating range to ensure there is no obstruction.
2. Refer to the specification chart to determine the proper diameter hole to cut for your speaker model. The template provided also gives the proper cutout size.
3. Mark the locations for the mounting screws. Drill the holes with a 1/8" bit.
4. Feed the speaker wires through the cutout and connect to the speaker terminals. Be sure to observe proper polarity when connecting the wires. The speaker's positive terminal is indicated with a "+".
5. On models with slotted holes, fit the speaker into the cutout and install the screws in the slots at the top and bottom. This will allow you to rotate the speaker to match the remaining mounting holes. When aligned, tighten the screws.
6. Tighten the screws until the speaker is snug in place to prevent rattling. Do not over tighten the screws.

NOTE: If needed, use the adapter plate provided to mount the speaker.  
See Adapter Plate Templates at the end of this manual.

### T252-S Only

Removing tabs for some installations

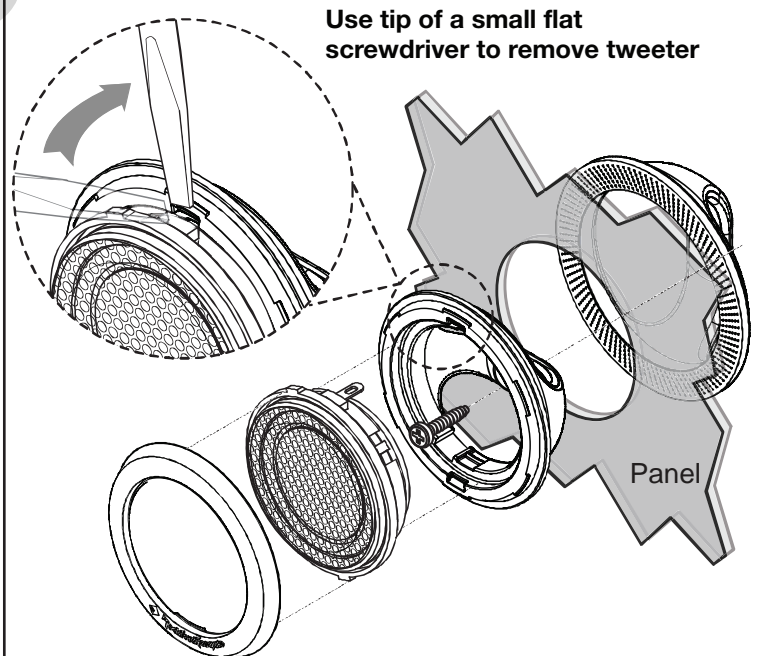
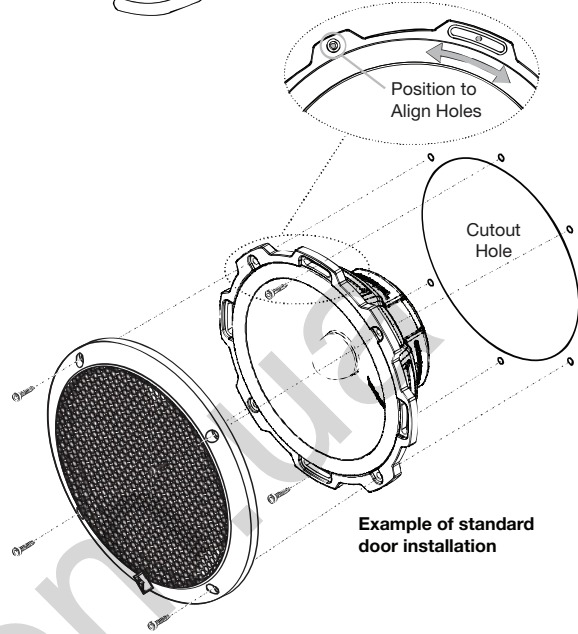
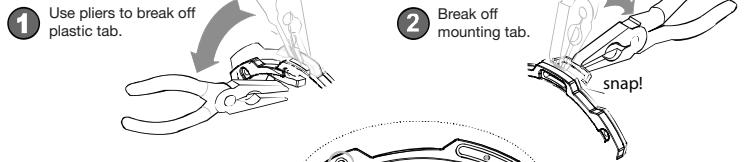

Example of Discreet Dual Clamp (DDC™) Tweeter Mounting (Flush Mount)

## FEATURES

### Discreet Dual Clamp (DDC™) Tweeter Mount

Every aspect of the new Tweeter design has been completely re-engineered to allow for maximum ease of installation and fitment. This optimized patent pending design provides concentric clamping pressure around the perimeter of the mounting hole.

The “mounting cups” are in fact not “cups” at all, but rather unobtrusive “clamps” that quickly and easily mount in a standard 1.75 inch (45mm) hole saw opening with a single center screw securing with balanced pressure to both faces of the mounting surface. From there, the tweeter simply snaps into place and is secured by a snap-on trim ring. Removal is easy if needed. The protective grille on the tweeter is non-removable and an integral part of the design.

## WIRING

### T2T-S Crossover Wiring

1. Use illustration for proper connection.
2. Be sure to maintain speaker polarity.
3. Connecting the positive wire to 0dB matches the amplitude of the tweeter to the mid-range (woofer).
4. Connecting positive wire to -2dB or -4dB to reduce the amplitude of the tweeter -2dB or -4dB lower than the mid-range, (ideal for tweeters located high in door panels and mid-range low in the kick panel).

## SPECIFICATIONS

T2 Components	T252-S	T2652-S	T2T-S
Nominal Diameter - inch (mm)	5.25 (133)	6.5 (165)	1.0 (25.4)
Description	Component System	Component System	Tweeter System
Nominal Impedance (ohms)	4	4	4
Frequency Response (Hz)	65Hz - 20kHz	55Hz - 22kHz	3kHz - 22kHz
Crossover Frequency (Hz)	3.5kHz	3kHz	3kHz
High-Pass Butterworth Crossover	18dB/octave	18dB/octave	18dB/octave
Low Pass Butterworth Crossover	12dB/octave	12dB/octave	-
Voice Coil Diameter - inch (mm)	1.1 (28)	1.2 (31)	1.0 (25.4)
Fs - Free Air Resonance (Hz)	65	55	1.8kHz
Qts	0.60	0.50	-
Vas - cu. ft. (Liter)	0.34 (9.6)	0.56 (16)	-
Xmax - inch (mm)	0.16 (4.0)	0.24 (6.0)	-
SPL (dB @ 1w/1m)	87 dB	89 dB	90 dB
Power Handling-Watts (RMS / Peak)	75 / 150	100 / 200	75 / 150
Rec. Amp Power-Watts (RMS)	22.5W ~ 75W	30W ~ 100W	22.5W ~ 75W
Mounting Diameter-inch (mm)	4.80 (122)	5.59 (142)	1.75 (45) (Flush Mount)
Mounting Depth-inch (mm)	2.03 (52)	2.51 (64)	0.95 (24) (Flush Mount)
<b>Includes Grille/Trim Ring</b>	<b>YES</b>	<b>YES</b>	<b>YES</b>
Trim Ring Diameter-inch (mm)	6.22 (158)	6.949 (177)	2.13 (54)
Trim Ring Height-inch (mm)	1.06 (27)	1.18 (30)	0.31 (8)
<b>Includes Adapter Plate</b>	<b>5"x7" / 6" x 9"</b>	<b>5"x7" / 6" x 9"</b>	<b>NO</b>

See figures on following pages.

Specifications subject to change without notice.

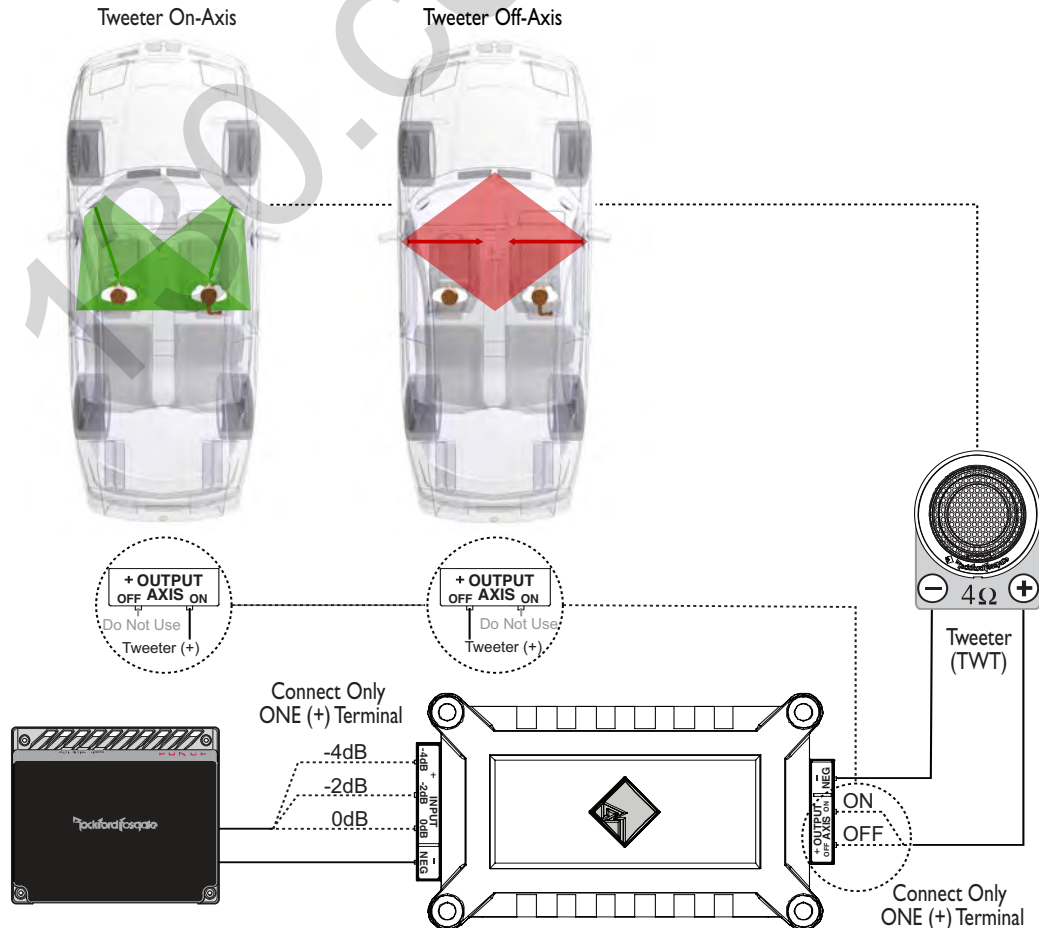

## T252-S & T2652-S Component Wiring

1. Use illustration for proper connection.
2. Be sure to maintain speaker polarity.

### Axis ON-OFF Switch

1. Set to ON or OFF to match position of tweeter relative to listener. Default OFF position satisfies most installations.

### dB Switch

1. 0dB matches the amplitude (no increase/no attenuation) of the tweeter to the same level as the mid-range (woofer).
2. +2dB increases and -2dB reduces the amplitude of tweeter in relation to the mid-range, (ideal when matching offset installation like tweeters located high in door panels and midranges low in kick panels).

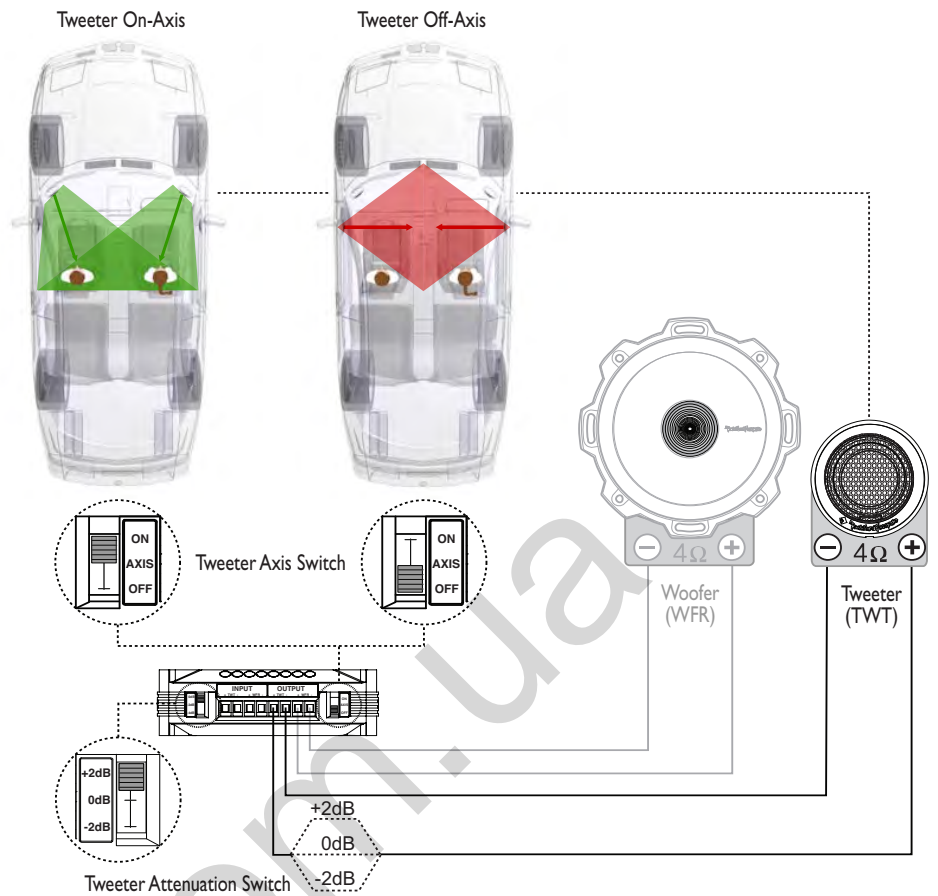

## T252-S & T2652-S Bi-Amp Crossover Wiring

1. Use illustration for proper connection and be sure to maintain speaker polarity.
2. Remove 4 screws from crossover bottom to detach cover.
3. When BI-AMP switched OFF for one amplifier, use only "TWT" input.
4. When BI-AMP switched ON for two dedicated amplifier, use both "TWT" and "WFR" inputs.

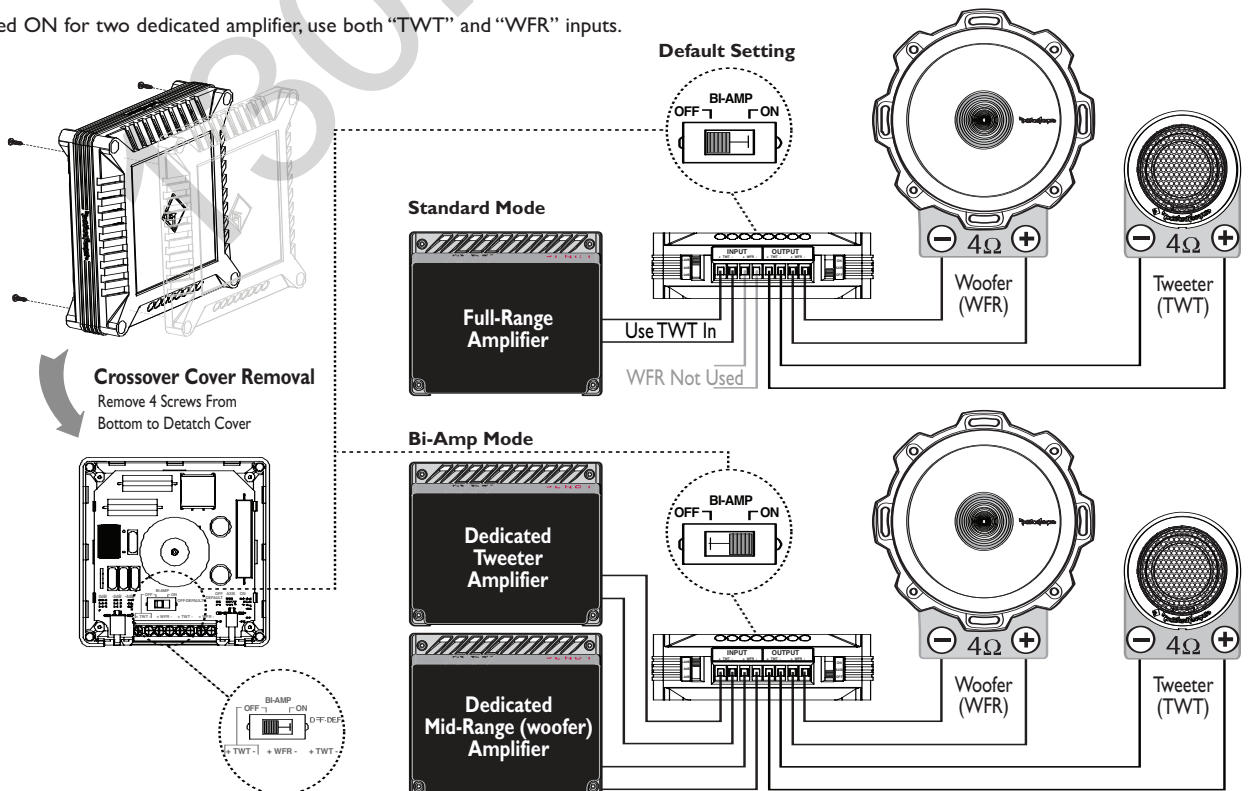

# SPECIFICATIONS

## T252-S

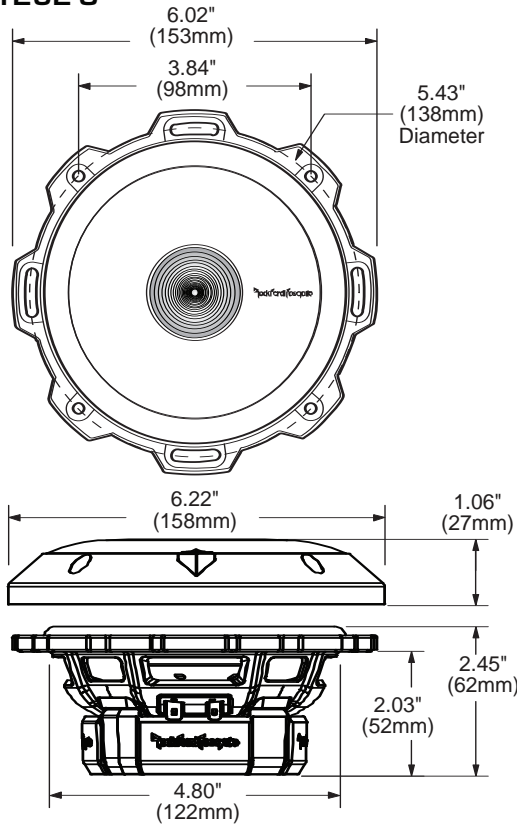

## T2652-S

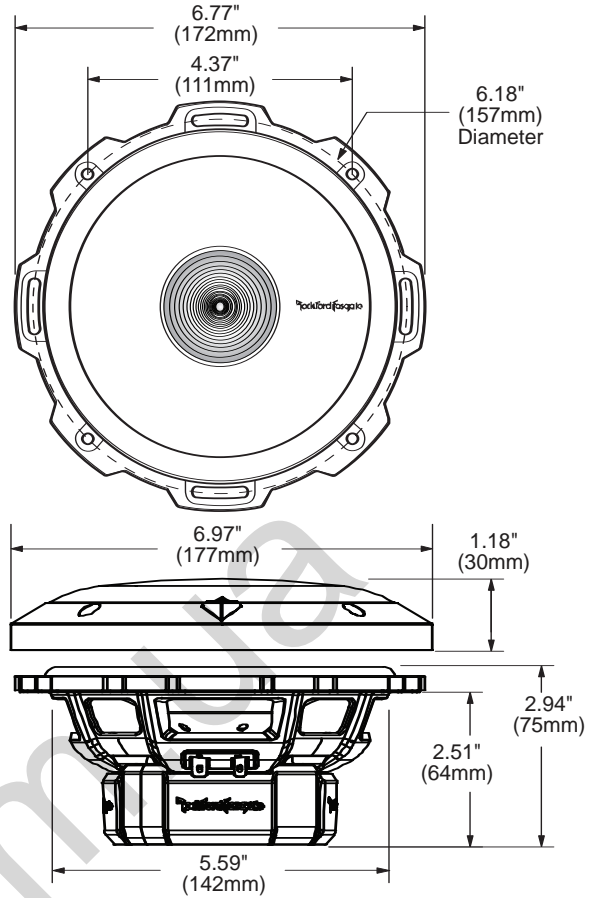

## Tweeter

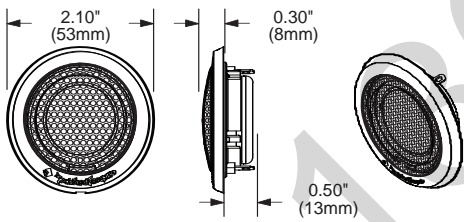

## Surface Mount

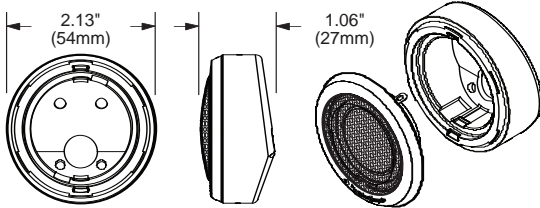

## Flush Mount

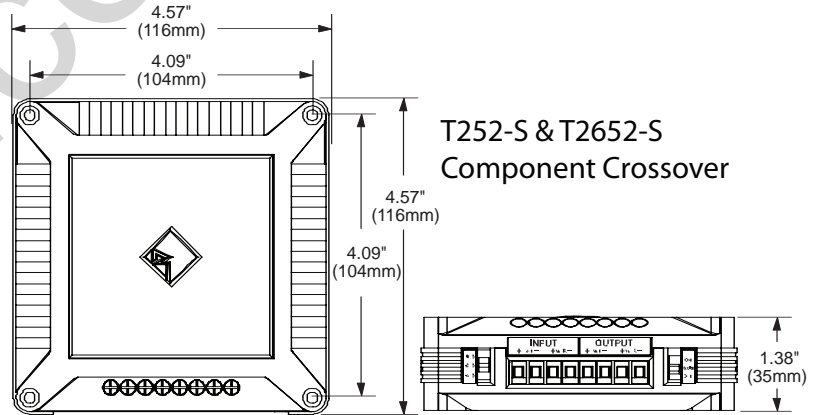
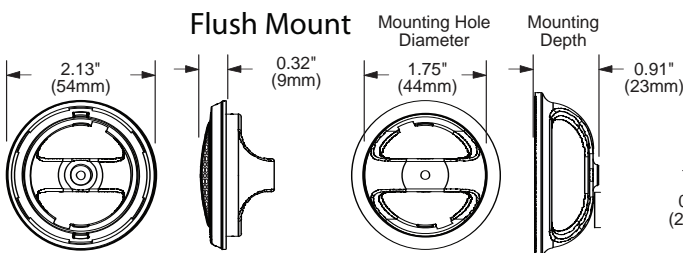

## T2T-S

## Tweeter Crossover

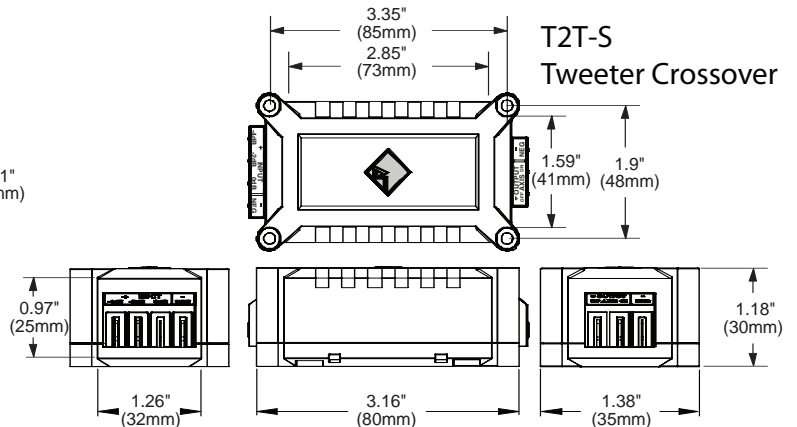

Specifications subject to change without notice.

## Français

 **MISE EN GARDE :** avant d'entamer l'installation, déconnectez la broche négative (-) de la batterie pour éviter tout risque de blessures, d'incendie ou de dommages à l'appareil.

### PRATIQUEZ UNE ÉCOUTE SANS RISQUES<sup>MD</sup>

Une exposition continue à des niveaux de pression acoustique supérieurs à 100 dB peut causer une perte d'acuité auditive permanente. Les systèmes audio de forte puissance pour auto peuvent produire des niveaux de pression acoustique bien au-delà de 130 dB. Faites preuve de bon sens et pratiquez une écoute sans risques

## Notes pour l'installation

Avant de commencer l'installation, suivez les règles ci-dessous :

1. Veillez à bien lire et comprendre les instructions avant d'essayer d'installer les haut-parleurs.
2. Par mesure de sécurité, débranchez le fil négatif de la batterie avant de commencer l'installation.
3. Pour faciliter le montage des haut-parleurs, il est conseillé d'installer tous les câbles au préalable.
4. Utilisez des connecteurs de haute qualité pour assurer une installation fiable et réduire au minimum la perte de signal ou de puissance.
5. Réfléchissez bien avant de percer. Veillez à ne pas couper ou percer le réservoir d'essence, le câblage électrique ou les conduites de carburant, de freinage hydraulique ou de dépression en travaillant sur un véhicule. En cas d'installation sur un bateau, veillez à ne pas couper ou percer la coque principale.
6. Ne jamais faire passer de fils sous le véhicule. Leur installation à l'intérieur du véhicule ou de la coque assure la meilleure protection.
7. Évitez de faire passer des fils sur des bords tranchants ou dans des orifices à arêtes vives. Utilisez des bagues en caoutchouc ou en plastique pour protéger les fils traversant une plaque de métal, notamment le tablier.

## Montage

1. Déterminez l'emplacement des haut-parleurs. Veillez à ce que la surface plane soit assez grande pour assurer un contact uniforme du haut-parleur. Vérifiez que l'emplacement est assez profond pour le haut-parleur ; en cas de montage dans une portière, actionnez toutes les commandes (fenêtres, serrures, etc.) jusqu'aux extrémités de leurs courses pour vous assurer qu'il n'y a pas d'obstruction.
2. Consultez le tableau des caractéristiques pour déterminer le diamètre de l'orifice à découper pour votre modèle de haut-parleur. Le gabarit fourni donne aussi le bon diamètre de découpe.
3. Marquez l'emplacement des vis de montage. Percez les trous avec une mèche de 1/8 de pouce (3,2 mm).
4. Faites passer les fils de haut-parleur à travers l'orifice découpé et branchez-les aux bornes du haut-parleur. Veillez à bien respecter la polarité lors du branchement. La borne positive du haut-parleur est indiquée par un « + ».
5. Sur les modèles à trous allongés, mettez le haut-parleur en place dans la découpe et installez les vis dans les trous du haut et du bas. Vous pourrez alors faire tourner le haut-parleur pour l'aligner sur les autres trous de montage. Une fois cet alignement effectué, serrez les vis.
6. Serrez les vis jusqu'à ce que le haut-parleur soit bien ajusté, de façon à prévenir tout cliquetis, mais évitez tout serrage excessif.

**REMARQUE:** Utilisez si nécessaire la plaque d'adaptation fournie pour monter le haut-parleur. Voir les gabarits de plaque d'adaptation à la fin de cette notice.

## Español

 **PRECAUCIÓN:** Antes de la instalación, desconecte el terminal negativo de la batería (-) para prevenir daño a la unidad, incendio y/o posibles lesiones.

### PRACTIQUE EL SONIDO SEGURO

El contacto continuo con niveles de presión de sonido superiores a 100 dB puede causar la pérdida permanente de la audición. Los sistemas de sonido para automóviles de alta potencia pueden producir niveles de presión de sonido superiores a los 130 dB. Use su sentido común y practique el sonido seguro.

## Consideraciones para la instalación

Antes de comenzar cualquier instalación, siga estas simples normas:

1. Asegúrese de leer cuidadosamente y de entender las instrucciones antes de tratar de instalar estos altavoces.
2. Por seguridad, desconecte el conductor negativo de la batería antes de comenzar la instalación.
3. Para facilitar el montaje, sugerimos que tienda todos los cables antes de montar sus altavoces en su sitio.
4. Utilice conectores de alta calidad para tener una instalación confiable y para reducir al mínimo las pérdidas de señal o de potencia.
5. ¡Piense siempre antes de perforar! Tenga cuidado de no cortar ni perforar en tanques de combustible, tuberías de combustible, frenos o hidráulicas, tuberías de vacío o cableado eléctrico al trabajar en un vehículo. Si la instalación se hace en un bote, tenga cuidado de no cortar ni perforar a través del casco principal.
6. Nunca tienda cables abajo del vehículo. Tender los cables adentro del vehículo o casco proporciona la mejor protección.
7. Evite tender cables arriba o a través de bordes filosos. Use arandelas aislantes de caucho para proteger los cables tendidos a través de metal, especialmente la mampara cortafuegos.

## Montaje

1. Determine adónde se montará los altavoces. Asegúrese de que haya un área suficientemente grande para montar de manera plana el altavoz. Asegúrese de que el lugar de montaje sea suficientemente profundo para que quepa el altavoz, si se monta en una puerta, accione todas las funciones (ventanas, cerradura, etc.) en toda su gama de funcionamiento para asegurarse de que no haya obstrucciones.
2. Consulte la tabla de especificaciones para determinar cuales son los diámetros correctos para el agujero a cortar para su modelo de altavoz. La plantilla proporcionada también le da la medida correcta del recorte.
3. Marque las localidades para los tornillos de montaje. Perfore los agujeros usando una broca de 1/8 pulg.
4. Tienda los cables del altavoz a través del recorte y conecte a los terminales del altavoz. Asegúrese de usar la polaridad correcta al conectar los cables. El terminal positivo del altavoz está identificado con un símbolo "+".
5. En los modelos con agujeros ranurados, coloque el altavoz en el recorte e instale los tornillos en las ranuras en la parte superior e inferior. Esto le permitirá hacer girar el altavoz para que coincida con los agujeros de montaje restantes. Una vez alineados, apriete los tornillos.
6. Apriete los tornillos hasta que el altavoz esté ajustado en su sitio para evitar vibraciones. No apriete demasiado los tornillos.

**NOTA:** Use la placa adaptadora proporcionada para montar el altavoz. Consulte las plantillas de las placas adaptadoras al final de este manual.

## Deutsch

 **VORSICHT:** Entfernen Sie vor dem Einbau den negative Batteriepol, um Schäden am Gerät, Feuer bzw. mögliche Verletzungen zu vermeiden.

### PRAKTIZIEREN SIE SICHEREN SOUND

Fortgesetzte Geräuschdruckpegel von über 100 dB können beim Menschen zu permanentem Hörverlust führen. Leistungsstarke Autosoundsysteme können Geräuschdruckpegel erzeugen, die weit über 130 dB liegen. Bitte wenden Sie gesunden Menschenverstand an und praktizieren Sie sicheren Sound.

## Einbauüberlegungen

Befolgen Sie vor dem Einbau diese einfachen Regeln:

1. Lesen Sie die Anleitung sorgfältig, bevor Sie versuchen diese Lautsprecher einzubauen.
2. Entfernen Sie vor dem Einbau aus Sicherheitsgründen das negative Kabel von der Batterie.
3. Um die Montage zu erleichtern, empfehlen wir alle Kabel vor der Befestigung Ihrer Lautsprecher zu verlegen.
4. Verwenden Sie nur Qualitätsstecker, um einen zuverlässigen Einbau zu gewährleisten und Signal- und Stromverlust zu minimieren.
5. Denken Sie nach, bevor Sie bohren! Achten Sie darauf, nicht in den Benzintank, die Benzin-, Brems- oder hydraulischen Leitungen, Vakuumleitungen oder Elektrokabel zu schneiden oder zu bohren, wenn Sie am Fahrzeug arbeiten. Achten Sie beim Einbau in einem Boot darauf, nicht durch den Bootsrumpf zu schneiden oder zu bohren.
6. Verlegen Sie Kabel nie unter dem Fahrzeug. Die Kabel im Fahrzeug oder Bootsrumpf zu verlegen, bietet den besten Schutz.
7. Vermeiden Sie es, Kabel über scharfe Kanten zu verlegen. Verwenden Sie Gummi- oder Plastikringe, um Kabel zu schützen, die durch Metall verlegt werden (besonders die Feuerwand).

## Befestigung

1. Entscheiden, wo die Lautsprecher befestigt werden sollen. Gewährleisten, dass der Platz ausreicht, um den Lautsprecher gleichmäßig zu befestigen. Gewährleisten, dass die Befestigungsstelle ausreichende Tiefe für den Lautsprecher hat; beim Einbau in einer Türe alle Funktionen (Fenster, Schloss usw.) in ihrem ganzen Bereich ausprobieren um zu gewährleisten, dass keine Blockierung eintritt.
2. Die Tabelle in den Technischen Daten gibt den richtigen Lochdurchmesser für Ihr Lautsprechermodell zum Ausschneiden an. Die beiliegende Schablone zeigt ebenfalls die richtige Ausschneidegröße an.
3. Die Stellen für die Befestigungsschrauben markieren. Die Löcher mit einer 1/8-Zoll (3,2 mm) Bohrer Spitze bohren.
4. Die Lautsprecherkabel durch das Loch führen und an den Lautsprecheranschlüssen anschließen. Beim Anschließen der Kabel die ordnungsgemäße Polarität beachten. Der positive Anschluss des Lautsprechers ist mit einem „+“ markiert.
5. Bei Modellen mit geschlitzten Löchern den Lautsprecher in das Loch einpassen und die Schrauben in den Schlitzen oben und unten befestigen. Dadurch können Sie den Lautsprecher so drehen, dass die übrigen Befestigungslöcher passen. Nach der Ausrichtung die Schrauben anziehen.
6. Die Schrauben anziehen, bis der Lautsprecher eng an seinem Platz anliegt, um Klappern zu verhindern. Die Schrauben nicht zu fest anziehen.

**HINWEIS:** Falls erforderlich die beiliegende Adapterplatte bei der Befestigung des Lautsprechers verwenden. Siehe Adapterplatten-Schablonen am Ende dieser Anleitung.

## Italiano

 **ATTENZIONE:** Prima dell'installazione, scollegate il terminale negativo (-) della batteria per evitare danni all'unità, pericoli d'incendio e/o potenziali lesioni personali.

### OSSERVATE LE REGOLE DEL "SUONO SENZA PERICOLI"

La costante esposizione a livelli di pressione acustica al di sopra dei 100dB possono causare la perdita permanente dell'udito. I sistemi audio ad alta potenza possono produrre livelli di pressione acustica ben superiori ai 130dB. Si consiglia il buon senso e l'osservanza delle regole del "suono senza pericoli".

## Considerazioni sull'installazione

Prima di iniziare qualsiasi operazione d'installazione, vi consigliamo di seguire queste semplici regole:

1. Assicuratevi di aver letto tutte le istruzioni con cura e di averle capite prima di effettuare qualsiasi tentativo d'installazione nei confronti dell'unità.
2. Per motivi di sicurezza, scollegate il cavo negativo dalla batteria prima di dare l'avvio all'installazione.
3. Per facilitare il montaggio, vi suggeriamo di far scorrere tutti i fili prima di montare la vostra unità nella sua ubicazione.
4. Usate connettori di alta qualità per garantire un'installazione che dà affidamento e per ridurre al minimo la perdita di segnali o di potenza.
5. State attenti prima di trapanare! Cercate di non trapanare e di non incidere i serbatoi della benzina; le condutture del carburante, dei freni, del sistema idraulico e a depressione; nonché i fili elettrici quando state lavorando su qualsiasi veicolo.
6. Non fate mai scorrere i fili sotto il veicolo. Avrete la protezione migliore facendo scorrere i fili all'interno del veicolo.
7. Evitate di far scorrere i fili sopra o attraverso delle estremità affilate. Usate guarnizioni di tenuta in gomma o in plastica per proteggere qualsiasi filo che passi attraverso del metallo, soprattutto il parafiamma.

## Montaggio

1. Decidete dove montare gli altoparlanti. Assicuratevi che sia un'area abbastanza grande per poter montare l'altoparlante a livello e abbastanza profonda per poterlo collocare comodamente. Se lo montate all'interno di uno sportello, controllate tutte le funzioni (finestre, serrature, ecc.), una alla volta, per assicurarvi che non ci siano ostruzioni.
2. Fate riferimento alla tabella delle specifiche per stabilire il diametro corretto del foro che dovrete praticare per il modello del vostro altoparlante. Il modello fornito anche dà la dimensione adeguata del ritaglio.
3. Marcare le posizioni per le viti di montaggio. Praticare i fori con una punta da trapano di 1/8 di pollice (3,2 mm).
4. Passare i cavi del diffusore tramite l'apertura e collegarli ai terminali. Verificare che la polarità sia corretta quando si collegano i cavi. Il terminale positivo del diffusore è identificato dal "+".
5. Nei modelli con fori a slot, adattare il diffusore nel foro ritagliato e inserire le viti negli slot in alto e in basso. Così facendo si potrà ruotare il diffusore per allinearlo con i rimanenti fori di montaggio. Serrare le viti quando si è ottenuto l'allineamento.
6. Per evitare rumore dovuto a vibrazioni serrare le viti finché il diffusore non sia saldamente in posizione. Non serrare le viti in modo eccessivo.

**NOTA:** Se necessario, della piastra di adattamento in dotazione. Vedere Sagome per la piastra di adattamento alla fine del presente manuale.



## Français

### Câblage du filtre T2T-S

1. Voir le branchement correct sur l'illustration.
2. Veillez à maintenir la polarité du haut-parleur.
3. Le branchement du fil positif à la borne 0 dB accorde l'amplitude du tweeter sur celle du haut-parleur.
4. Le branchement du fil positif à la borne -2 dB ou -4 dB réduit l'amplitude du tweeter de -2 ou -4 dB par rapport à celle du haut-parleur de médium (idéal lorsque les tweeters sont situés en haut des panneaux de porte et les haut-parleurs de médium dans les panneaux de seuil).

### T252-S & T2652-S composants de câblage

1. Utiliser l'illustration pour une bonne connexion.
2. Assurez-vous de maintenir orateur polarité.

### Axis ON-OFF

1. Réglé sur ON ou OFF match à la position relative de tweeter à l'auditeur. Par défaut OFF satisfait la plupart des installations.

### Switch dB

1. 0dB correspond à l'amplitude (pas d'augmentation / sans atténuation) des le tweeter au même niveau que le milieu de gamme (woofer).
2. +2dB augmente -2dB et réduit l'amplitude de tweeter en rapport à la moyenne gamme, (idéal pour adapter l'installation offset comme les tweeters situé en haut des panneaux de porte et Midranges faible en kick panneaux).

### T252-S & T2652-S Bi-Amp Coscover câblage

1. Utiliser l'illustration pour la connexion et assurez-vous de maintenir orateur polarité.
2. Suppression de 4 vis de liaison à bas detach couverture.
3. BI-AMP Lorsque l'arrêt d'un amplificateur, utilisez uniquement "TWT" input.
4. Lorsque BI-AMP tension pour deux dédiés amplificateur; utiliser les deux "TWT" et "WFR" inputs.

## Español

### Cableado del cruce del T2T-S

1. Utilice la ilustración para hacer una conexión correcta.
2. Asegúrese de mantener la polaridad del altavoz.
3. Conectar el cable positivo a 0dB hace que coincida la amplitud del tweeter con el altavoz.
4. Conectar el cable positivo a -2dB o -4dB reduce la amplitud del tweeter -2dB o -4dB menos que la gama de medias, (ideal para tweeters situados altos en paneles de puertas y de frecuencias medias situados bajos en la placa de defensa).

### T252-S & T2652-S Componente de cableado

1. Utilice la ilustración para una correcta conexión.
2. Asegúrese de mantener la polaridad de los altavoces.

### Eje de encendido y apagado

1. En ON u OFF para que coincida con la posición de los tweeter en relación con el oyente. Por defecto posición OFF cumple la mayoría de las instalaciones.

### dB

1. Coincide con la amplitud 0dB (sin aumento o no de atenuación), de el tweeter en el mismo nivel que los de gama media (woofer).
2. +2B de aumento y -2dB reduce la amplitud de los tweeter en relación con la gama media, (ideal cuando se pongan en venta compensar la instalación tweeters de alta como situado en los paneles de puerta y en el tiro bajo midranges paneles).

### T252-S & T2652-S Bi-Amp Coscover de cableado

1. Utilice la ilustración para la correcta conexión y asegúrese de mantener la polaridad de los altavoces.
2. Retire los 4 tornillos de la parte inferior de cruce detach a cubrir.
3. Cuando BI-AMP apagado de un amplificador, utilice sólo "TWT" de entrada.
4. Cuando BI-AMP encendido durante dos dedicados amplificador, use tanto "TWT" y "WFR" insumos.

## Deutsch

### T2T-S Crossover-Verkabelung

1. Zum ordnungsgemäßen Anschließen die Illustration benutzen.
2. Dabei die Lautsprecherpolarität beachten.
3. Das Anschließen des positiven Drahts an 0 dB stimmt die Amplitude des Hochtöners auf den Lautsprecher ab.
4. Das Anschließen des positiven Drahts an -2dB oder -4dB reduziert die Amplitude des Hochtöners auf -2dB oder -4dB niedriger als den Mitteltöner (ideal für Hochtöner, die sich hoch in Türpaneelen befinden, und Mitteltöner, die sich tief im Fußpaneel befinden).

### T252-S & T2652-S Komponente Verdrahtung

1. Verwenden Sie für die richtige Verbindung Illustration.
2. Stellen Sie sicher, dass die Aufrechterhaltung Lautsprecher Polarität.

### Axis ON-OFF-Schalter

1. Auf ON oder OFF, um Position der Hochtöner relativ zum Hörer. Standard-OFF-Position entspricht den meisten Installationen.

### dB-Schalter

1. Mit der Amplitude 0 dB (keine Zunahme / keine Dämpfung) von der Hochtöner auf der gleichen Ebene wie die Mid-Range-(TT).
2. +2dB -2dB erhöht und verringert die Amplitude der Hochtöner in Bezug auf die Mid-Range-, (ideal, wenn Offset-Installation Hochtöner hoch wie in Türverkleidungen und Mitteltöner gering Kick Platten).

### T252-S & T2652-S Bi-Amp Coscover Verdrahtung

1. Verwenden Sie für die richtige Verbindung Illustration und vergewissern Sie sich, um Lautsprecher Polarität.
2. Nehmen Sie 4 Schrauben von unten nach Crossover detach decken.
3. Bei der Bi-Amp ausgeschaltet für einen Verstärker, verwenden Sie nur "TWT" Input.
4. Bei der Bi-Amp eingeschaltet für zwei spezielle Verstärker, sowohl "TWT" und "WFR" Eingänge.

## Italiano

### Impianto di crossover del T2T-S

1. Per il collegamento corretto riferirsi all'illustrazione.
2. Accertarsi di mantenere la polarità del diffusore.
3. Il collegamento del filo del positivo a 0dB fa corrispondere l'ampiezza del tweeter al diffusore.
4. Il collegamento del filo del positivo a -2dB o -4dB riduce l'ampiezza del tweeter di -2dB o -4dB al disotto del midrange (particolarmente indicato per tweeter posti in alto nei pannelli della portiera e per midrange posti in basso nel kick panel).

### T252-S & T2652-S Componente Cablaggio

1. Usa illustrazione per la corretta connessione.
2. Ricordati di mantenere la polarità dei diffusori.

### Asse ON-OFF

1. Impostato su ON o OFF per corrispondenza di posizione rispetto al tweeter ascoltatore. Default OFF posizione soddisfa la maggior parte degli impianti.

### dB

1. 0dB corrisponde l'ampiezza (nessun aumento / no attenuazione) di il tweeter è allo stesso livello, come il mid-range (woofer).
2. +2dB aumenta -2dB e riduce l'ampiezza del tweeter nella rispetto al mid-range, (ideale quando corrispondenti compensare l'installazione come tweeter situato in alto pannelli porta e midrange a basso contenuto di calcio pannelli).

### T252-S & T2652-S Bi-Amp Wiring Coscover

1. Usa illustrazione per la corretta connessione ed essere certi di mantenere la polarità dei diffusori.
2. 4 Rimuovere le viti dal fondo di crossover detach copertina.
3. Quando BI-AMP spento per un amplificatore, utilizzare solo "TWT" input.
4. Quando BI-AMP attivata per due amplificatore dedicato, l'uso sia "TWT" e "WFR" ingressi.

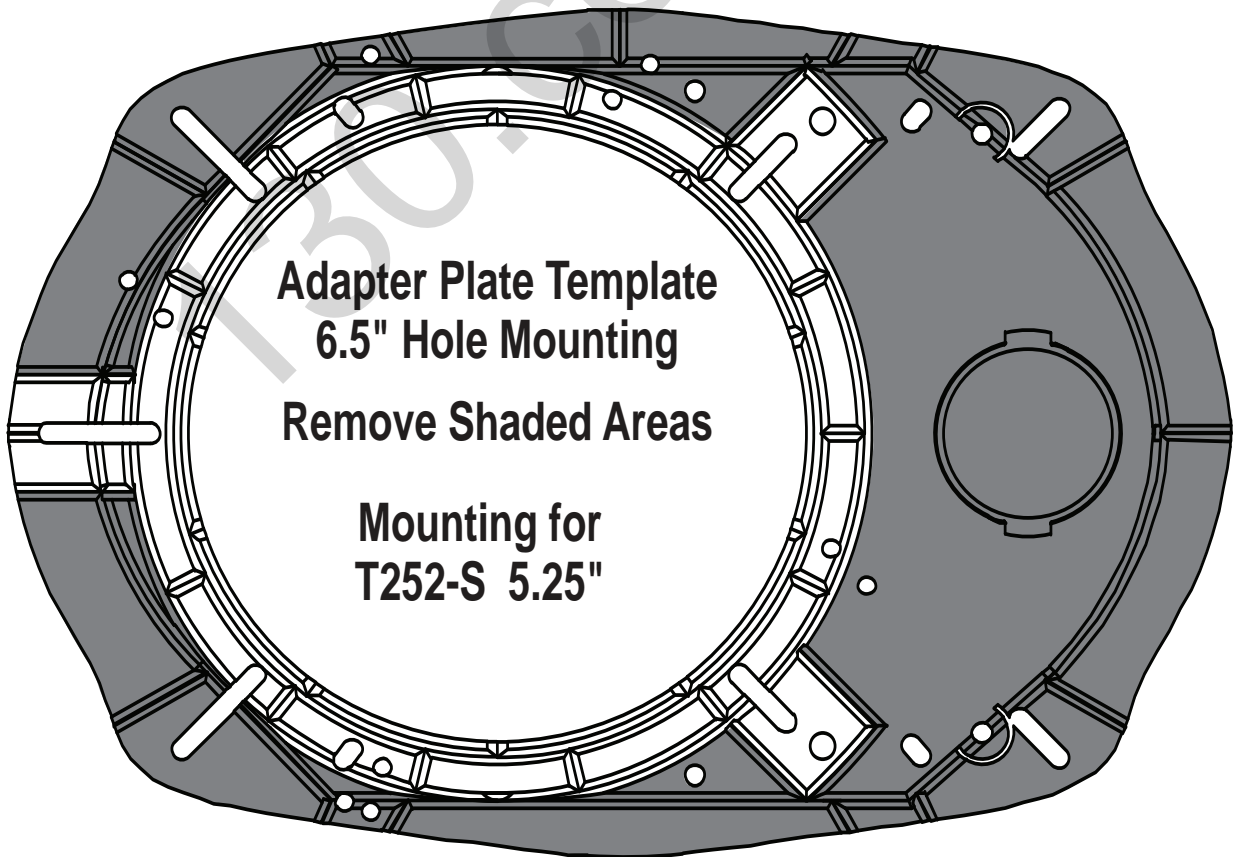
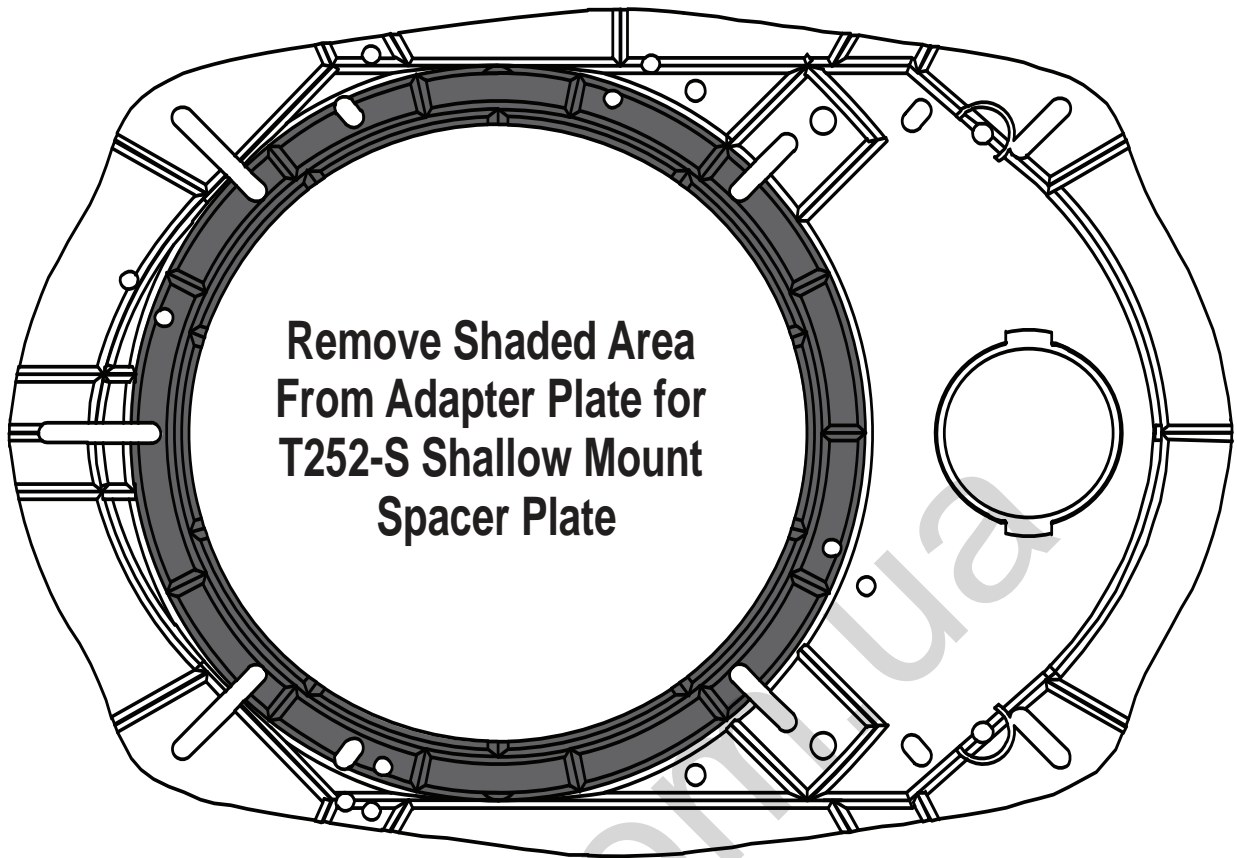

**For 5"x7" Hole Mounting - Remove Dark Shaded Areas**

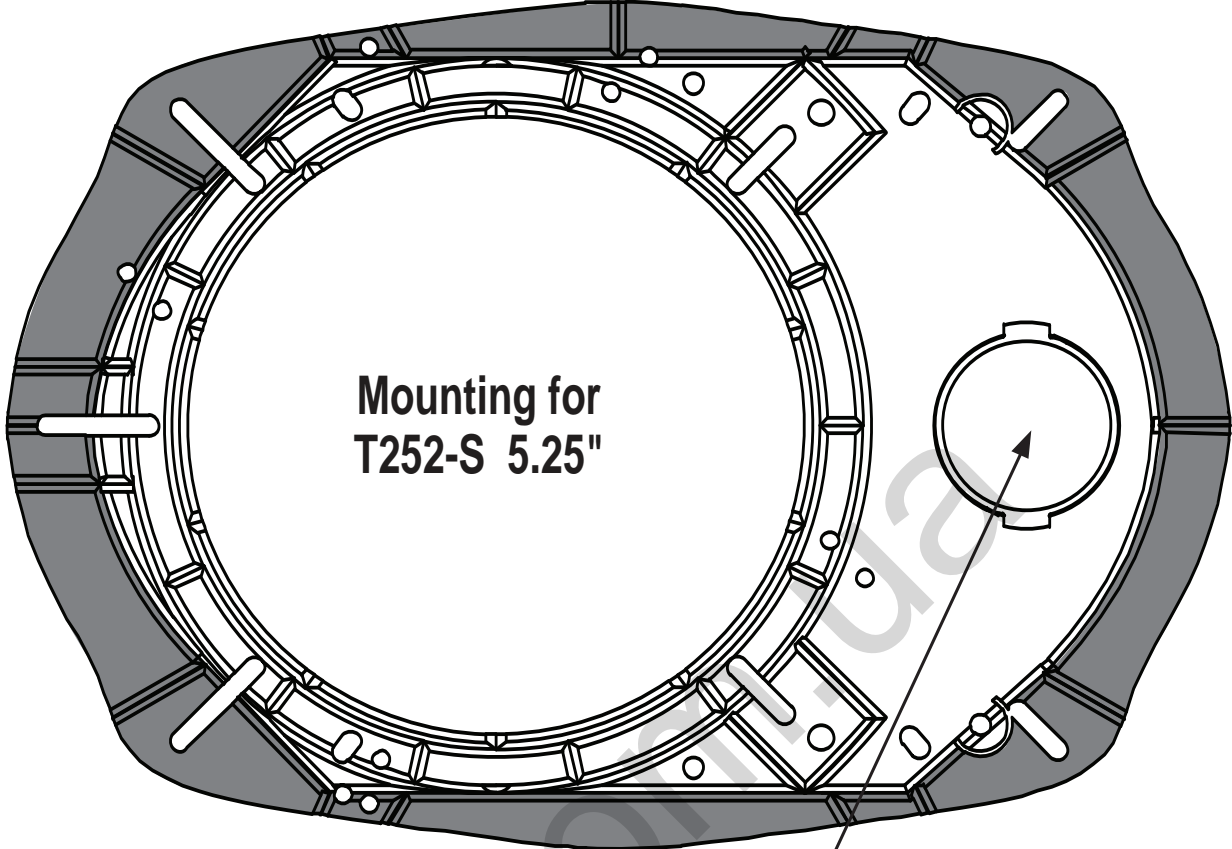

**Remove For Tweeter**

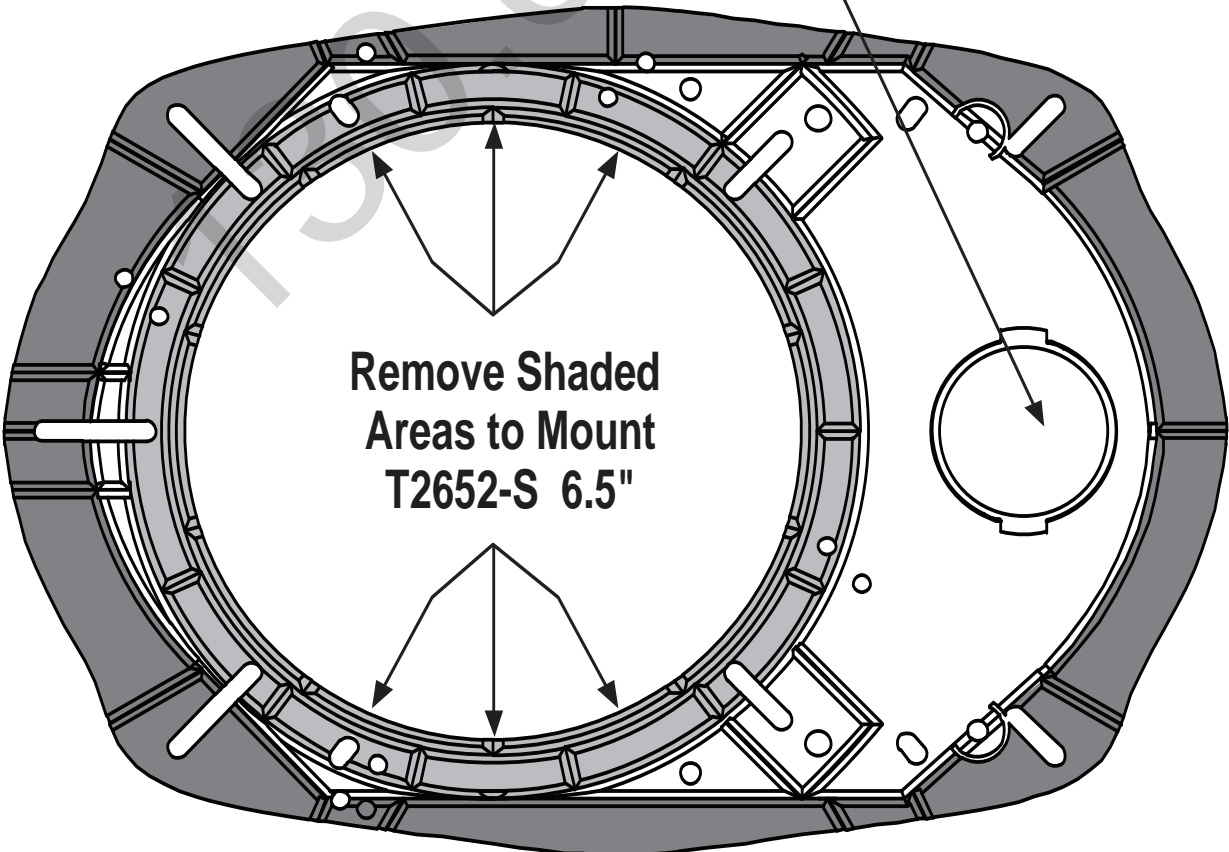

# T252-S Component System

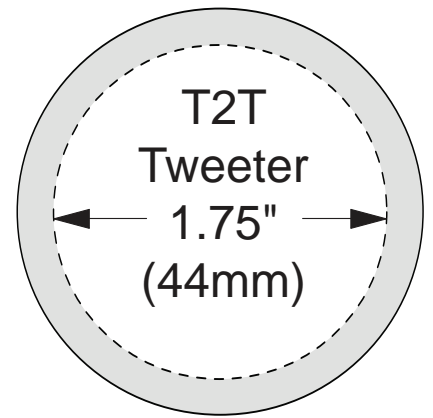

## Mounting Template

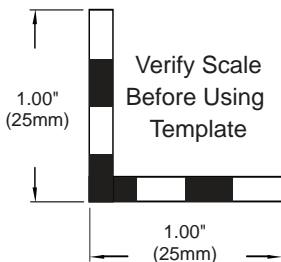
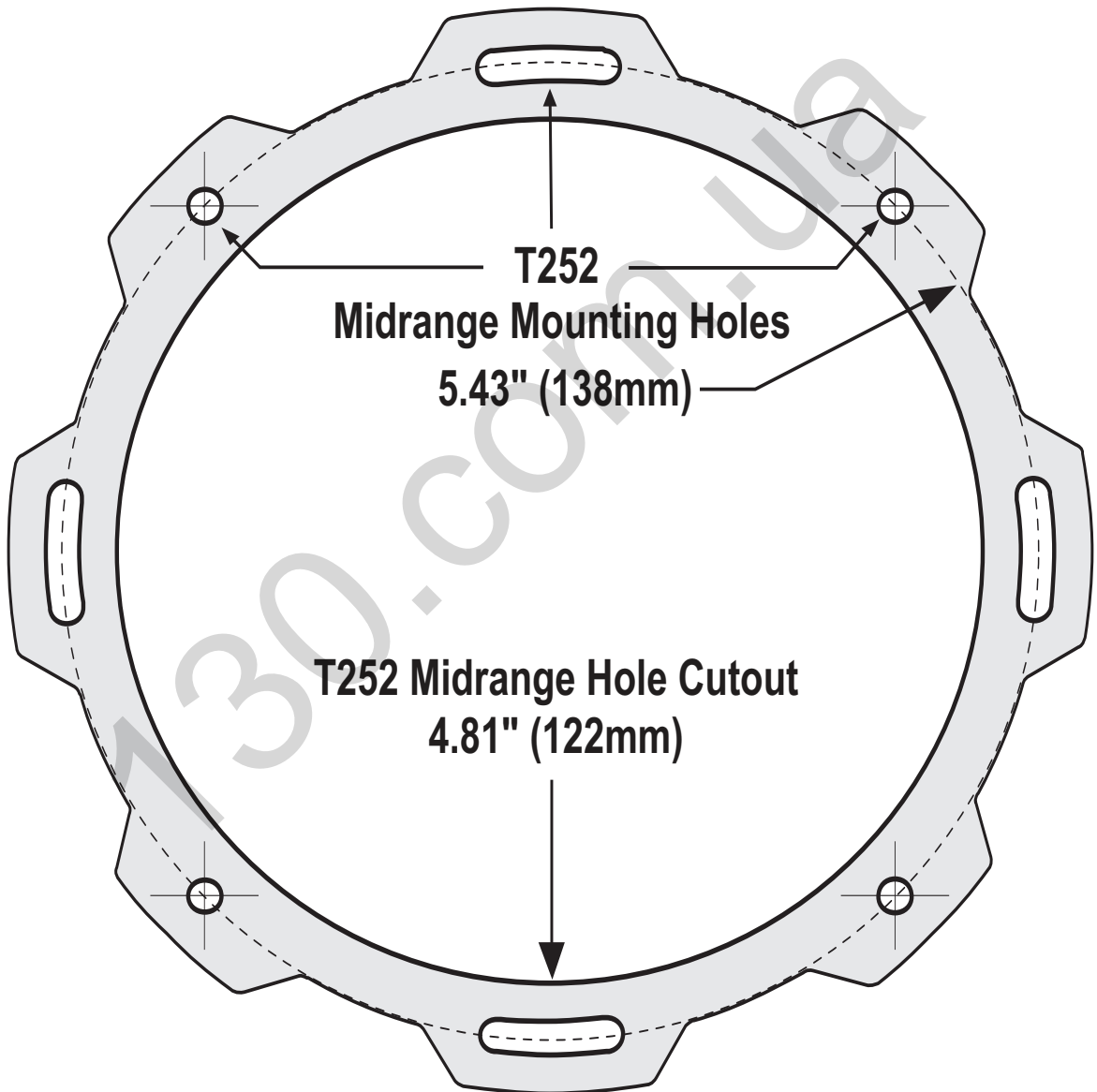

# T2652-S Component System

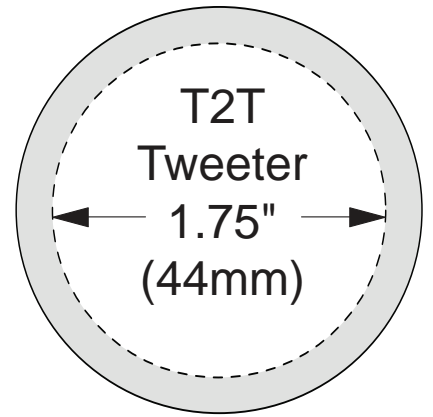

## Mounting Template

