



PHONES

0 (800) 800 130
(050) 462 0 130
(063) 462 0 130
(067) 462 0 130

130
COM.UA

Internet store of
autogoods



SKYPE

km-130

CAR RECEIVERS — Receivers • Media receivers and stations • Native receivers • CD/DVD changers • FM-modulators/USB adapters • Flash memory • Facia plates and adapters • Antennas • Accessories |
CAR AUDIO — Car audio speakers • Amplifiers • Subwoofers • Processors • Crossovers • Headphones • Accessories | TRIP COMPUTERS — Universal computers • Model computers • Accessories |
GPS NAVIGATORS — Portable GPS • Built-in GPS • GPS modules • GPS trackers • Antennas for GPS navigators • Accessories | VIDEO — DVR • TV sets and monitors • Car TV tuners • Cameras • Videomodules
• Transcoders • Car TV antennas • Accessories | SECURITY SYSTEMS — Car alarms • Bike alarms • Mechanical blockers • Immobilizers • Sensors • Accessories | OPTIC AND LIGHT — Xenon • Bixenon • Lamps
• LED • Stroboscopes • Optic and Headlights • Washers • Light, rain sensors • Accessories | PARKTRONICS AND MIRRORS — Rear parktronic • Front parktronic • Combined parktronic • Rear-view mirrors
• Accessories | HEATING AND COOLING — Seat heaters • Mirrors heaters • Screen-wipers heaters • Engine heaters • Auto-refrigerators • Air conditioning units • Accessories | TUNING — Vibro-isolation
• Noise-isolation • Tint films • Accessories | ACCESSORIES — Radar-detectors • Handsfree, Bluetooth • Windowlifters • Compressors • Beeps, loudspeakers • Measuring instruments • Cleaners • Car seats
• Miscellaneous | MOUNTING — Installation kits • Upholstery • Grilles • Tubes • Cable and wire • Tools • Miscellaneous | POWER — Batteries • Converters • Start-charging equipment • Capacitors
• Accessories | MARINE AUDIO AND ELECTRONICS — Marine receivers • Marine audio speakers • Marine subwoofers • Marine amplifiers • Accessories | CAR CARE PRODUCTS — Additives • Washer fluid •
Care accessories • Car polish • Flavors • Adhesives and sealants | LIQUID AND OIL — Motor oil • Transmission oil • Brake fluid • Antifreeze • Technical lubricant



In store "130" you can find and buy almost all necessary goods for your auto in Kyiv and other cities, delivery by ground and postal services. Our experienced consultants will provide you with exhaustive information and help you to chose the very particular thing. We are waiting for you at the address

<https://130.com.ua>



РУКОВОДСТВО ПО УСТАНОВКЕ

Club 34F

Club 44F

Club 54F

Club 64FSL

Club 644F

Club 864F

Club 964M

Club 64

Club 64SQ

Club 194T
Autogoods "130"

Club 64CSQ

Club 64C

Club 64CTP

Club 34F

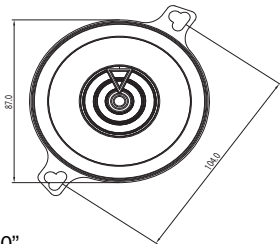
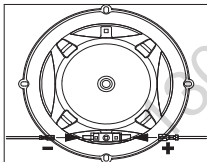
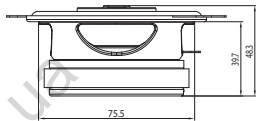

Autogoods "130"

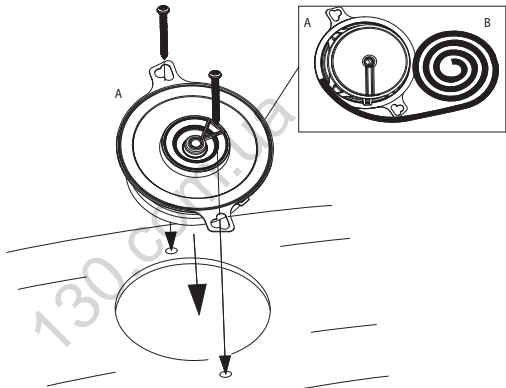
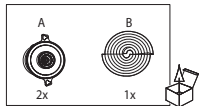

Autogoods "130"

Технические Характеристики

- Тип: 2-полосные акустические системы 3-1/2" (87 мм)
- Мощность: 25 Вт RMS, 75 Вт пик
- Чувствительность (при 2,83 В/м): 89 дБ
- Частотный диапазон: 90 Гц – 20 кГц
- Номинальный импеданс: 3,0 Ом

Параметры Тила-Смолла

- BL (Tm): 2,873
- DCR (ohms): 2,26
- Mms (g): 3,723
- Sd (cm²): 44,18
- Cms (µm/N): 0,491
- Vas (l): 1,3574
- Fs (Hz): 117,7
- Qes: 0,755
- Qms: 7,777
- Qts: 0,688
- Crossover Point: 4kHz

Autogoods "130"

Club 44F

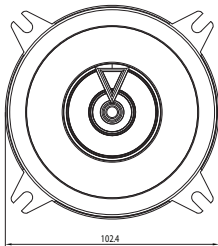
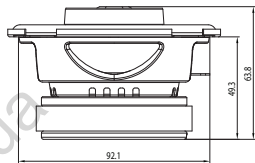
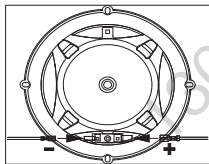

Autogoods "130"

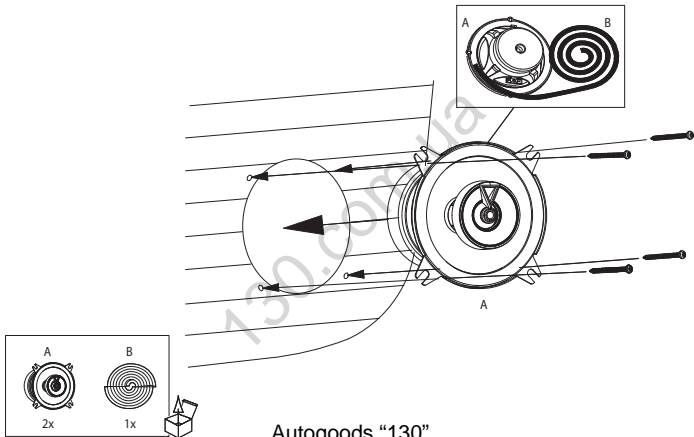

Технические Характеристики

- Тип: 2-полосные акустические системы 4" (100 мм)
- Мощность: 35 Вт RMS, 105 Вт пик
- Чувствительность (при 2,83 В): 90 дБ
- Частотный диапазон: 75 Гц – 20 кГц
- Номинальный импеданс: 3,0 Ом

Параметры Тиля-Смолла

- BL (Tm): 3,783
- DCR (ohms): 2,46
- Mms (g): 6,608
- Sd (cm²): 63,62
- Cms (µm/N): 0,750
- Vas (l): 4,2937
- Fs (Hz): 71,5
- Qes: 0,510
- Qms: 6,495
- Qts: 0,473
- Crossover Point: 3kHz

Autogoods "130"

Club 54F

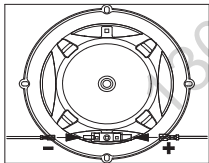
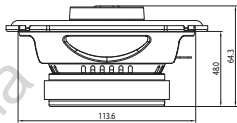

Autogoods "130"

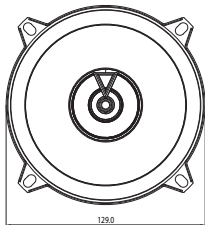

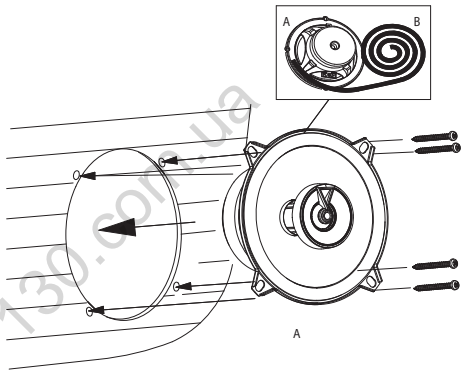
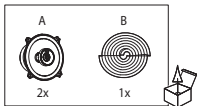

Autogoods "130"

Технические Характеристики

- Тип: 2-полосные акустические системы 5-1/4" (130 мм)
- Мощность: 45 Вт RMS, 135 Вт пик
- Чувствительность (при 2,83 В): 91 дБ
- Частотный диапазон: 75 Гц – 20 кГц
- Номинальный импеданс: 3,0 Ом

Параметры Тила-Смолла

- BL (Tm): 3,563
- DCR (ohms): 2,24
- Mms (g): 9,484
- Sd (cm²): 103,87
- Cms (µm/N): 0,274
- Vas (l): 4,1850
- Fs (Hz): 98,7
- Qes: 1,036
- Qms: 8,608
- Qts: 0,925
- Crossover Point: 3kHz

Autogoods "130"

Club 64FSL

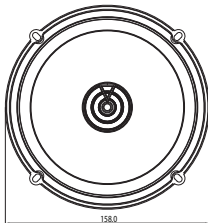
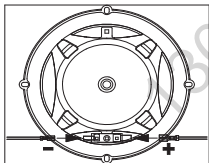
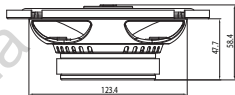

Autogoods "130"

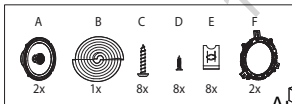
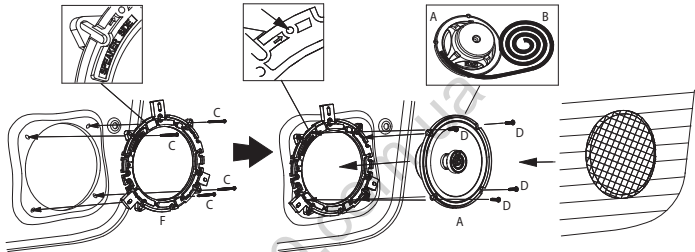

Autogoods "130"

Технические Характеристики

- Тип: 2-полосные акустические системы с уменьшенной монтажной глубиной 6-1/2" (160 мм)
- Мощность: 55 Вт RMS, 165 Вт пик
- Чувствительность (при 2,83 В): 92 дБ
- Частотный диапазон: 55 Гц – 20 кГц
- Номинальный импеданс: 3,0 Ом

Параметры Тила-Смолла

- BL (Tm): 3,739
- DCR (ohms): 2,41
- Mms (g): 9,934
- Sd (cm²): 122,72
- Cms (µm/N): 0,278
- Vas (l): 5,9287
- Fs (Hz): 95,7
- Qes: 1,032
- Qms: 11,357
- Qts: 0,946
- Crossover Point: 4kHz

Autogoods "130"

Club 644F

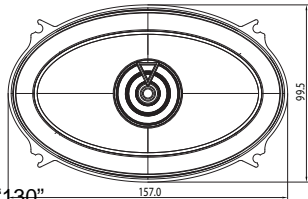
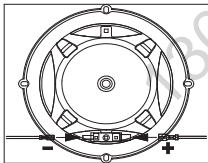
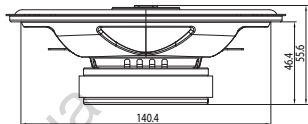

Autogoods "130"

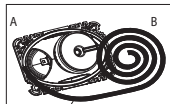
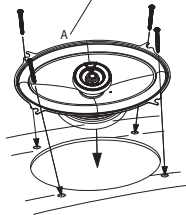
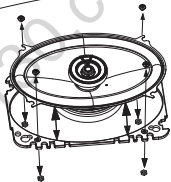
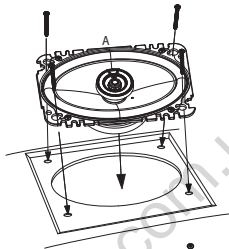
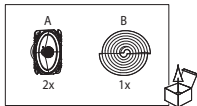

Autogoods "130"

Технические Характеристики

- Тип: 2-полосные акустические системы 4" x 6" (100 мм x 152 мм)
- Мощность: 40 Вт RMS, 120 Вт пик
- Чувствительность (при 2,83 В): 92 дБ
- Частотный диапазон: 75 Гц – 20 кГц
- Номинальный импеданс: 3,0 Ом

Параметры Тила-Смолла

- BL (Tm): 3,296
- DCR (ohms): 2,5
- Mms (g): 7,86
- Sd (cm²): 86,59
- Cms (µm/N): 0,245
- Vas (l): 2,5977
- Fs (Hz): 114,7
- Qes: 1,303
- Qms: 12,752
- Qts: 1,182
- Crossover Point: 3kHz

Autogoods "130"

Club 864F

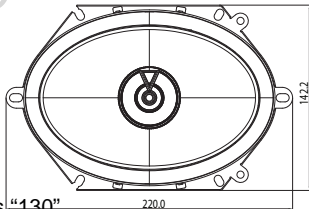
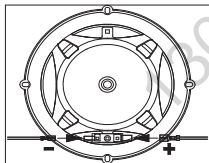
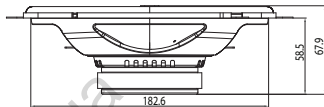

Autogoods "130"

220.0

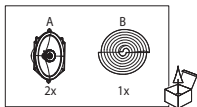
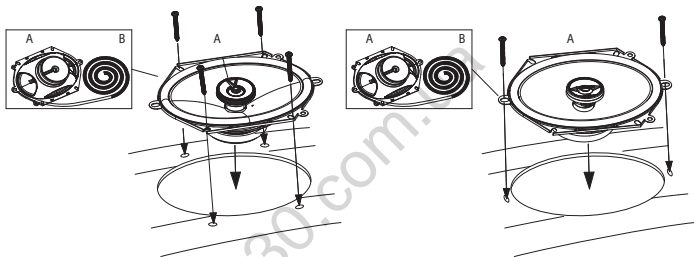

Autogoods "130"

Технические Характеристики

- Тип: 2-полосные акустические системы 6" x 8" (152 мм x 203 мм)
- Мощность: 60 Вт RMS, 180 Вт пик
- Чувствительность (при 2,83 В): 93 дБ
- Частотный диапазон: 65 Гц – 20 кГц
- Номинальный импеданс: 3,0 Ом

Параметры Тила-Смолла

- BL (Tm): 3,785
- DCR (ohms): 2,39
- Mms (g): 17,718
- Sd (cm²): 165,13
- Cms (µm/N): 0,336
- Vas (l): 12,9798
- Fs (Hz): 65,2
- Qes: 1,210
- Qms: 14,592
- Qts: 1,118
- Crossover Point: 3,5kHz

Autogoods "130"

Club 964M

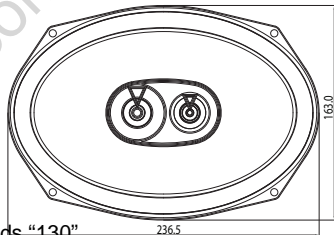
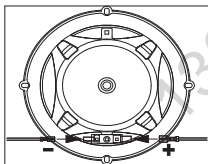
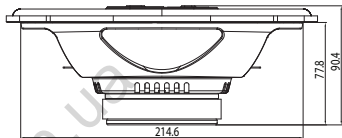

Autogoods "130"

236.5

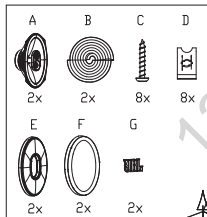

Autogoods "130"

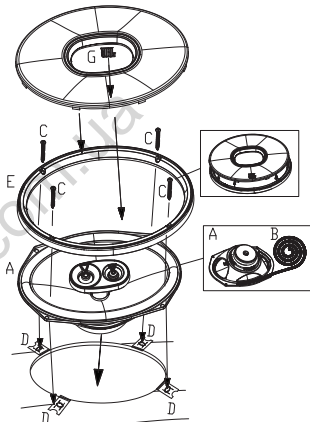

Технические Характеристики

- Тип: 3-полосные акустические системы 6" x 9" (152 мм x 230 мм)
- Мощность: 85 Вт RMS, 255 Вт пик
- Чувствительность (при 2,83 В): 93 дБ
- Частотный диапазон: 50 кГц – 20 кГц
- Номинальный импеданс: 3,0 Ом

Параметры Тила-Смолла

- BL (Tm): 4,063
- DCR (ohms): 2,63
- Mms (g): 23,163
- Sd (cm²): 226,98
- Cms (µm/N): 0,337
- Vas (l): 24,5866
- Fs (Hz): 56,9
- Qes: 1,321
- Qms: 11,751
- Qts: 1,188
- Crossover Point: 3kHz

Autogoods "130"

Club 64

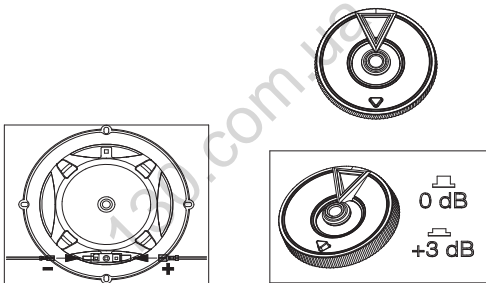

Autogoods "130"

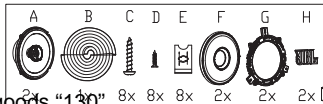
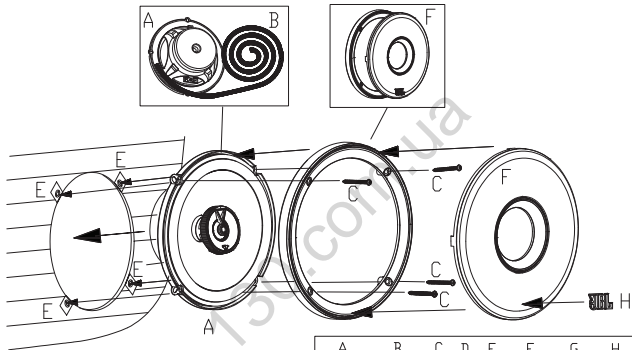

Autogoods "130"



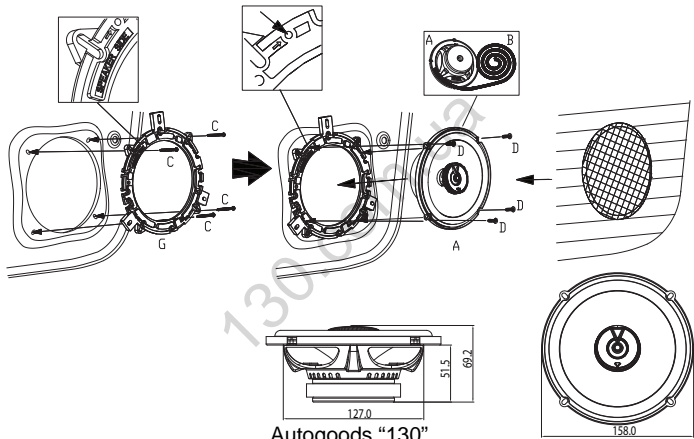

Autogoods "130"

Технические Характеристики

- Тип: 2-полосные акустические системы 6-1/2" (160 мм) с расширенными возможностями настройки
- Мощность: 60 Вт RMS, 180 Вт пик
- Чувствительность (при 2,83 В): 93 дБ
- Частотный диапазон: 48 Гц – 21 кГц
- Номинальный импеданс: 3,0 Ом

Параметры Тила-Смолла

- BL (Tm): 3,632
- DCR (ohms): 2,36
- Mms (g): 13,758
- Sd (cm²): 132,73
- Cms (µm/N): 0,378
- Vas (l): 9,4253
- Fs (Hz): 69,8
- Qes: 1,080
- Qms: 10,655
- Qts: 0,980
- Crossover Point: 3,5kHz

Autogoods "130"

Club 64SQ

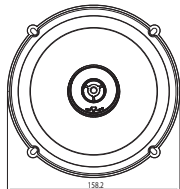
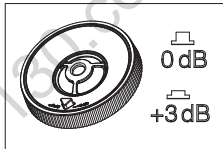
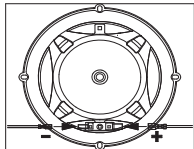
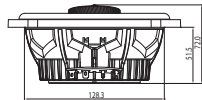

Autogoods "130"

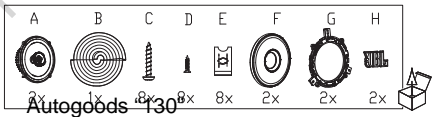
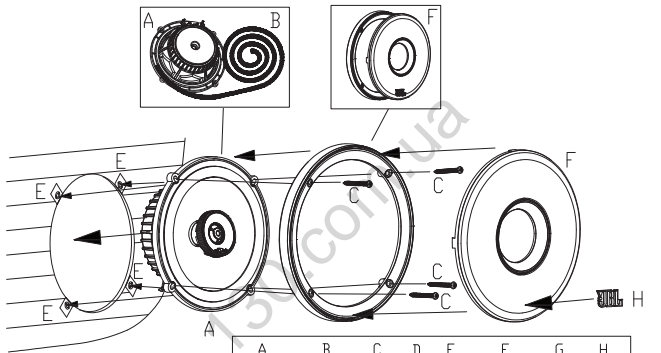

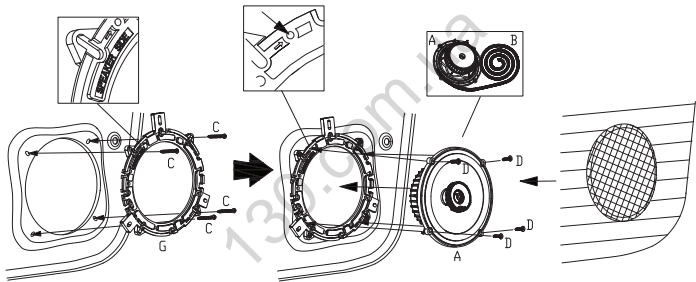

Autogoods "130"

Технические Характеристики

- Тип: 6-1/2" (160 мм) 2-полосный автомобильный динамик, разработанный для передачи звука превосходного качества.
- Мощность: 75 Вт RMS, 225 Вт пик
- Чувствительность (при 2,83 В): 93 дБ
- Частотный диапазон: 48 Гц – 21 кГц
- Номинальный импеданс: 3,0 Ом

Параметры Тила-Смолла

- BL (Tm): 3.748
- DCR (ohms): 2.12
- Mms (g): 12.273
- Sd (cm²): 132.73
- Cms (µm/N): 0.530
- Vas (l): 13.2162
- Fs (Hz): 62.4
- Qes: 0.724
- Qms: 9.037
- Qts: 0.671
- Crossover Point: 5 kHz

Autogoods "130"

Club 194T

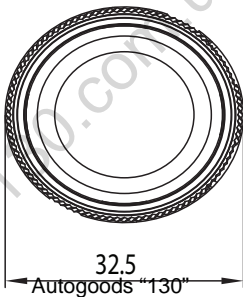
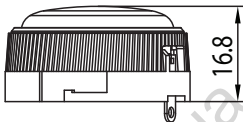

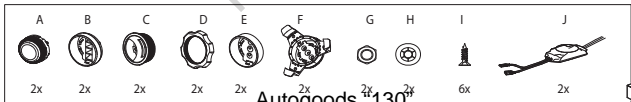
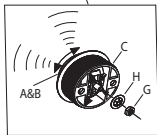
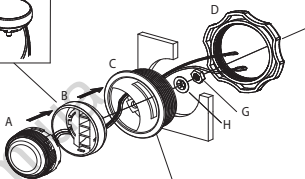
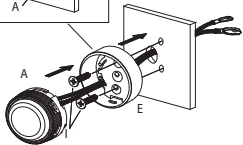
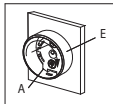

Autogoods 130



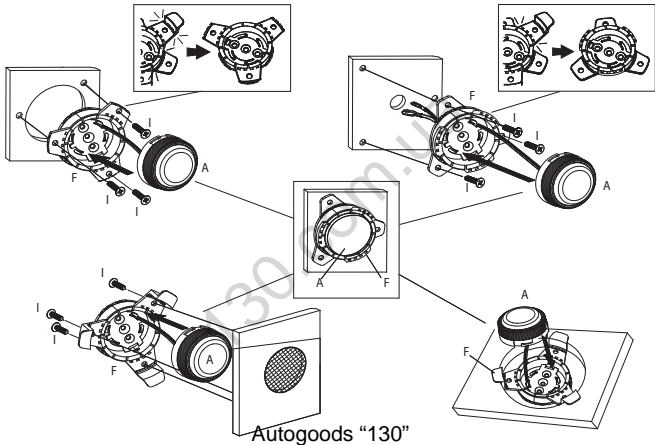

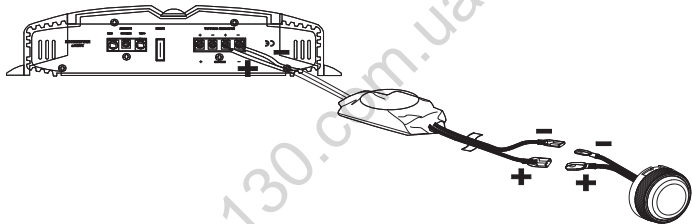

Autogoods "130"

Технические Характеристики

- Тип: Купольный ВЧ-динамик 3/4" (19 мм)
- Мощность: 50 Вт RMS, 150 Вт пик
- Чувствительность (при 2,83 В): 92 дБ
- Частотный диапазон: 3 кГц – 20 кГц
- Номинальный импеданс: 3,0 Ом

130.com.ua

Autogoods "130"

Club 64CSQ

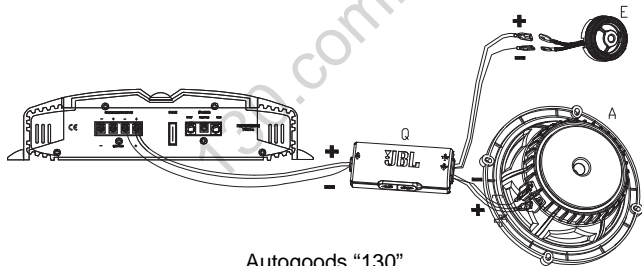
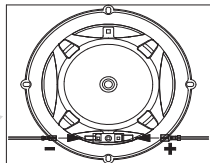

Autogoods "130"

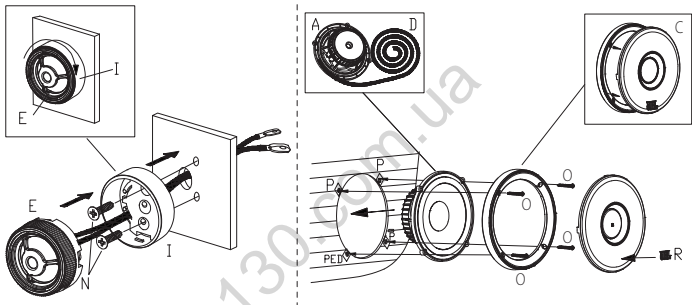

Autogoods "130"

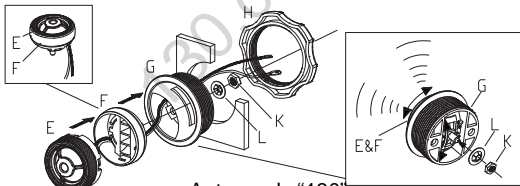
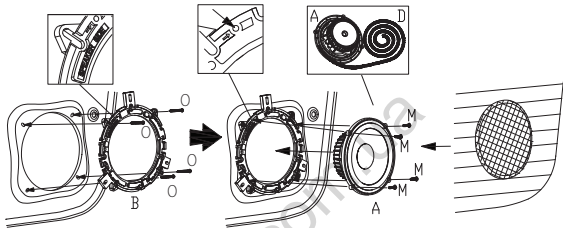

Autogoods "130"

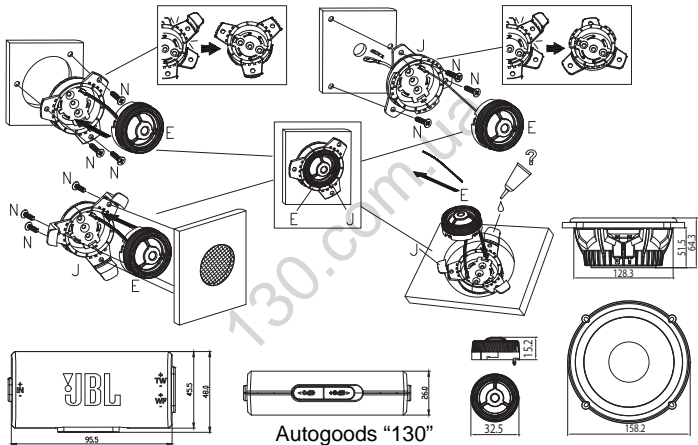

Технические Характеристики

- Тип: 6-1/2" (160 мм) 2-полосная компонентная акустическая система, разработанная для передачи звука превосходного качества.
- Мощность: 95 Вт RMS, 285 Вт пик
- Чувствительность (при 2,83 В): 93 дБ
- Частотный диапазон: 48 Гц – 21 кГц
- Номинальный импеданс: 3,0 Ом

Параметры Тила-Смолла

- BL (Tm): 3.776
- DCR (ohms): 2.09
- Mms (g): 13.238
- Sd (cm²): 132.73
- Cms (µm/N): 0.536
- Vas (l): 13.3648
- Fs (Hz): 59.7
- Qes: 0.728
- Qms: 8.315
- Qts: 0.670
- Crossover Point: 5 kHz

Autogoods "130"

Club 64C

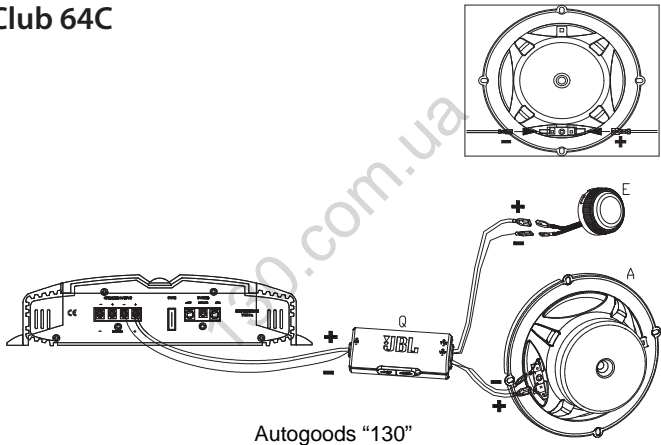

Autogoods "130"

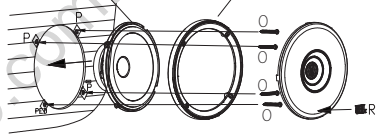
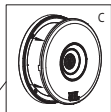
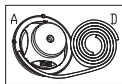
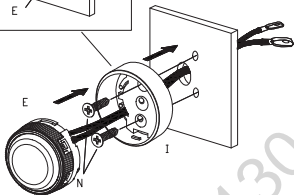
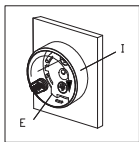

Autogoods 130



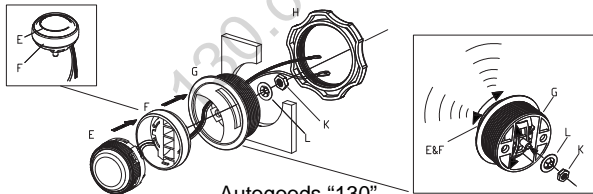
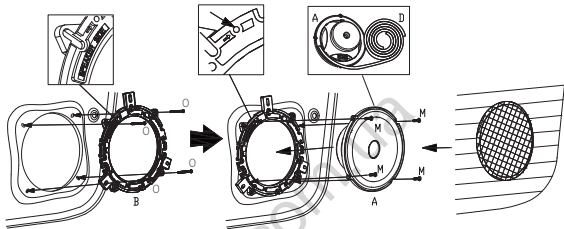

Autogoods "130"

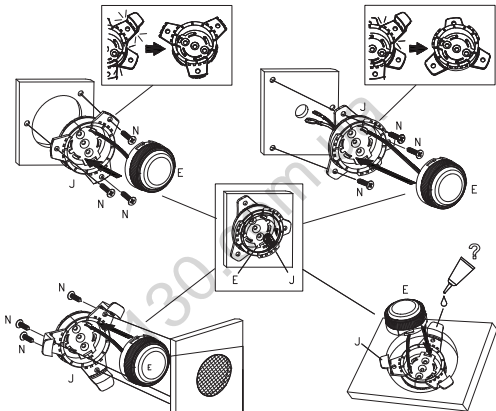

Autogoods "130"

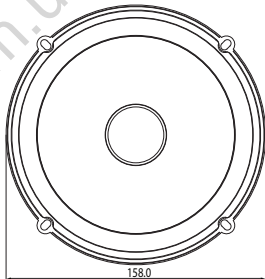
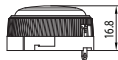
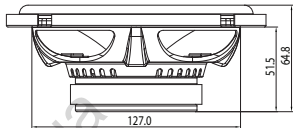
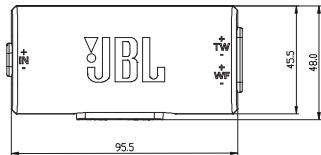

Autogoods "130"

Технические Характеристики

- Тип: 2-полосные компонентные акустические системы 6-1/2" (160 мм)
- Мощность: 70 Вт RMS, 210 Вт пик
- Чувствительность (при 2,83 В): 92 дБ
- Частотный диапазон: 55 Гц – 20 кГц
- Номинальный импеданс: 3,0 Ом

Параметры Тила-Смолла

- BL (Tm): 3,635
- DCR (ohms): 2,37
- Mms (g): 14,409
- Sd (cm²): 132,73
- Cms (µm/N): 0,257
- Vas (l): 6,4107
- Fs (Hz): 82,7
- Qes: 1,340
- Qms: 10,965
- Qts: 1,194
- Crossover Point: 5,5kHz

Autogoods "130"

Club 64CTP

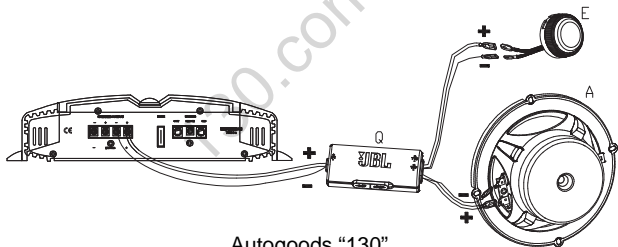
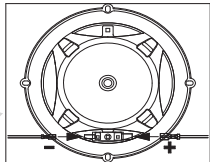

Autogoods "130"

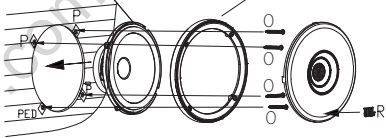
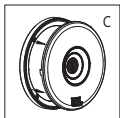
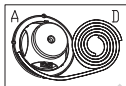
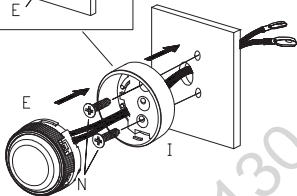
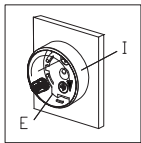

| A | B | C | D | E | F | G | H | I | J | K | L | M | N | O | P | Q | R | S | T | U | V | W | X | Y | Z |
|----|----|----|----|----|----|----|----|----|----|----|----|----|----|----|----|----|----|----|----|----|----|----|----|----|----|
| | | | | | | | | | | | | | | | | | | | | | | | | | |
| 2x | 2x | 2x | 1x | 2x | 2x | 2x | 2x | 2x | 2x | 2x | 2x | 8x | 6x | 8x | 8x | 2x | 8x | 2x | 2x | 2x | 2x | 2x | 4x | 2x | 2x |

Autogoods "130"



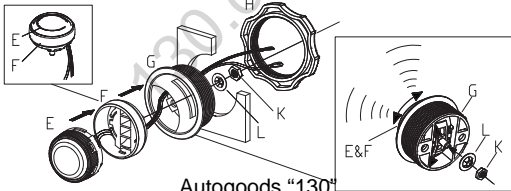
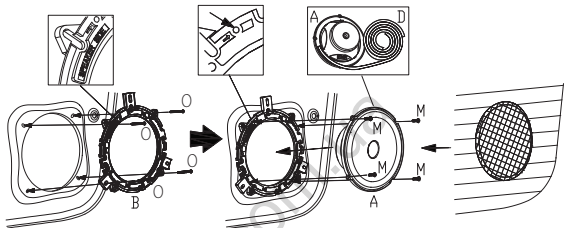

Autogoods "130"

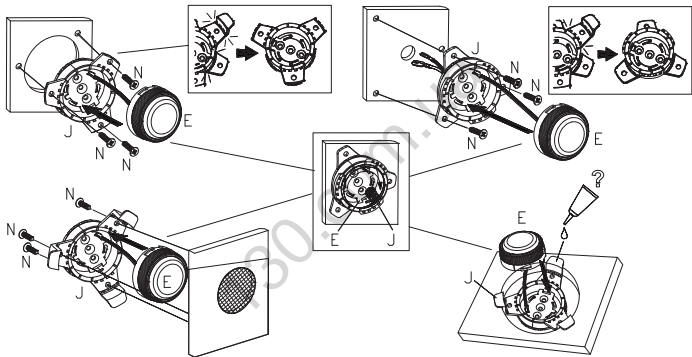

Autogoods "130"

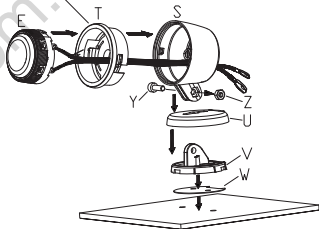
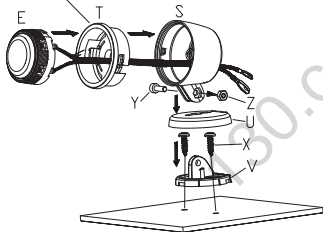

Autogoods "130"

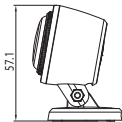
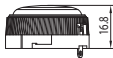
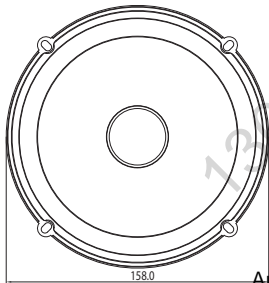
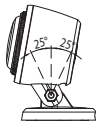
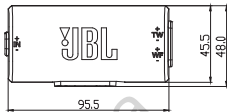
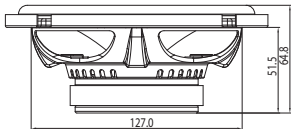

Autogoods "130

Технические Характеристики

- Тип: 2-полосные компонентные акустические системы 6-1/2" (160 мм) с конструкцией Tweeter Pod
- Мощность: 70 Вт RMS, 210 Вт пик
- Чувствительность (при 2,83 В): 92 дБ
- Частотный диапазон: 55 Гц – 20 кГц
- Номинальный импеданс: 3,0 Ом

Параметры Тила-Смолла

- BL (Tm): 3,635
- DCR (ohms): 2,37
- Mms (g): 14,409
- Sd (cm²): 132,73
- Cms (µm/N): 0,257
- Vas (l): 6,4107
- Fs (Hz): 82,7
- Qes: 1,340
- Qms: 10,965
- Qts: 1,194
- Crossover Point: 5,5kHz

Autogoods "130"



HARMAN International Industries,
Incorporated
8500 Balboa Boulevard, Northridge,
CA 91329 USA

© 2023 HARMAN International
Industries, Incorporated. Все

права защищены. JBL – это торговая марка компании HARMAN International Industries Incorporated, зарегистрированной в США и других странах.

Функции, характеристики и внешний вид могут изменяться без предварительного уведомления.

Autogoods “130”