



PHONES

0 (800) 800 130
(050) 462 0 130
(063) 462 0 130
(067) 462 0 130

130
COM.UA

Internet store of
autogoods



SKYPE

km-130

CAR RECEIVERS — Receivers • Media receivers and stations • Native receivers • CD/DVD changers • FM-modulators/USB adapters • Flash memory • Facia plates and adapters • Antennas • Accessories |
 CAR AUDIO — Car audio speakers • Amplifiers • Subwoofers • Processors • Crossovers • Headphones • Accessories | TRIP COMPUTERS — Universal computers • Model computers • Accessories |
 GPS NAVIGATORS — Portable GPS • Built-in GPS • GPS modules • GPS trackers • Antennas for GPS navigators • Accessories | VIDEO — DVR • TV sets and monitors • Car TV tuners • Cameras • Videomodules
 • Transcoders • Car TV antennas • Accessories | SECURITY SYSTEMS — Car alarms • Bike alarms • Mechanical blockers • Immobilizers • Sensors • Accessories | OPTIC AND LIGHT — Xenon • Bixenon • Lamps
 • LED • Stroboscopes • Optic and Headlights • Washers • Light, rain sensors • Accessories | PARKTRONICS AND MIRRORS — Rear parktronic • Front parktronic • Combined parktronic • Rear-view mirrors
 • Accessories | HEATING AND COOLING — Seat heaters • Mirrors heaters • Screen-wipers heaters • Engine heaters • Auto-refrigerators • Air conditioning units • Accessories | TUNING — Vibro-isolation
 • Noise-isolation • Tint films • Accessories | ACCESSORIES — Radar-detectors • Handsfree, Bluetooth • Windowlifters • Compressors • Beeps, loudspeakers • Measuring instruments • Cleaners • Car seats
 • Miscellaneous | MOUNTING — Installation kits • Upholstery • Grilles • Tubes • Cable and wire • Tools • Miscellaneous | POWER — Batteries • Converters • Start-charging equipment • Capacitors
 • Accessories | MARINE AUDIO AND ELECTRONICS — Marine receivers • Marine audio speakers • Marine subwoofers • Marine amplifiers • Accessories | CAR CARE PRODUCTS — Additives • Washer fluid •
 Care accessories • Car polish • Flavors • Adhesives and sealants | LIQUID AND OIL — Motor oil • Transmission oil • Brake fluid • Antifreeze • Technical lubricant



In store "130" you can find and buy almost all necessary goods for your auto in Kyiv and other cities, delivery by ground and postal services. Our experienced consultants will provide you with exhaustive information and help you to choose the very particular thing. We are waiting for you at the address

<https://130.com.ua>

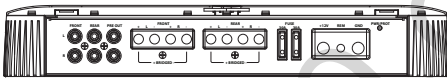
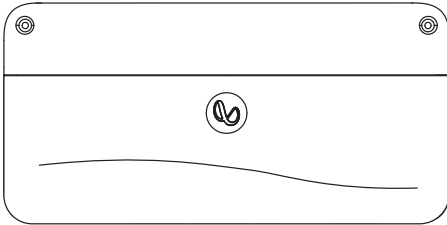

Owner's Manual	EN
Betjeningsvejledning	DA
Bedienungsanleitung	DE
Manual de propietario	ES
Käyttöopas	FI
Mode d'emploi	FR
Manuale d'istruzioni	IT
Gebruikershandleiding	NL
Instrukcja obsługi	PL
Manual do utilizador	PT
Bruksanvisning	SV
Kullanıcı Kılavuzu	TR
用户手册	ZH-CN
使用者手冊	ZH-TW
Panduan Pengguna	ID
取扱説明書	JP
사용자 설명서	KO

Торговая марка: JBL
 Назначение товара: Усилитель мощности
 Изготовитель: Харман Интернешнл Индастриз Инкорпорейтед, США, 06901 Коннектикут, г.Стамфорд, Атлантик Стрит 400, офис 1500
 Страна происхождения: Китай
 Импортёр в Россию: ООО «ХАРМАН РУС СиАйЭс», Россия, 127018, г.Москва, ул. Двинцев, д.12, к 1
 Гарантийный период: 1 год
 Информация о сервисных центрах: www.harman.com/ru тел. +7-800-700-0467
 Срок службы: 3 года



Товар сертифицирован
 Дата производства:

Дата изготовления устройства определяется по двум буквенным обозначениям из второй группы символов серийного номера изделия, следующих после разделительного знака «-». Кодировка соответствует порядку букв латинского алфавита, начиная с января 2010 года: 000000-MY0000000, где «M» - месяц производства (А - январь, В - февраль, С - март и т.д.) и «Y» - год производства (А - 2010, В - 2011, С - 2012 и т.д.).

Используйте устройство только по прямому назначению в соответствии с предоставленной инструкцией. Не пытайтесь самостоятельно вскрывать корпус товара и осуществлять ремонт. В случае обнаружения недостатков или дефектов, обращайтесь за гарантийным обслуживанием в соответствии с информацией из гарантийного талона. Особые условия хранения, реализации и (или) транспортировки не предусмотрены. Избегайте воздействия экстремальных температур, длительного воздействия влаги, сильных магнитных полей. Устройство предназначено для работы в жилых зонах. Срок годности не ограничен при соблюдении условий хранения.

产品中有害物质的名称及含量

部件名称	目标部件	有害物质或元素					
		铅 (Pb)	汞 (Hg)	镉 (Cd)	六价铬 (Cr (VI))	多溴联苯 (PBB)	多溴二苯醚 (PBDE)
箱体	外壳, 面板, 背板等	×	0	0	0	0	0
电路板	印刷电路板, 电路板上的电子零件, 内部相关连接线	×	0	0	0	0	0
零部件	电容, 连接器等	×	0	0	0	0	0
附件	电源线, 说明书, 包装等	0	0	0	0	0	0

本表格依据 SJ/T 11364 的规定编制

0: 表示该有害物质在该部件所有均质材料中的含量均在 GB/T 26572 规定的限量要求以下。

X: 表示该有害物质至少在该部件的某一均质材料中的含量超出 GB/T 26572 规定的限量求。



在中华人民共和国境内销售的电子电气产品上将印有“环保使用期”(EPAP)符号。

圆圈中的数字代表产品的正常环保使用年限。



WHAT'S IN THE BOX

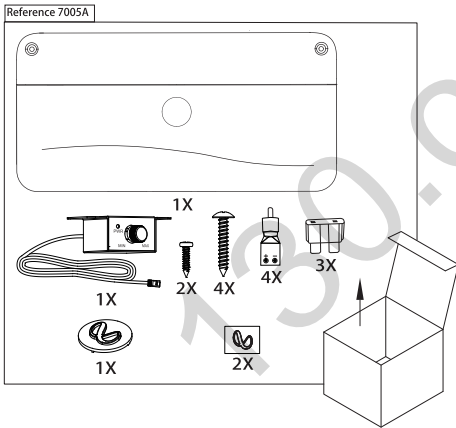
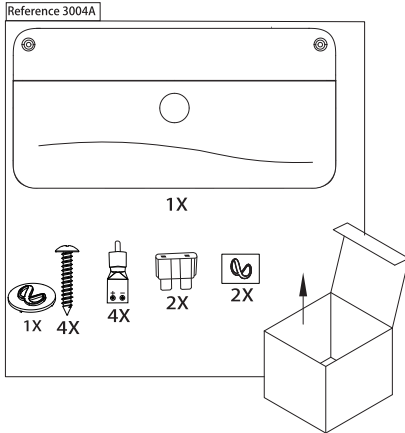

ACCESSING CONNECTORS/ CONTROL PANEL

1. Slide the panel cover down

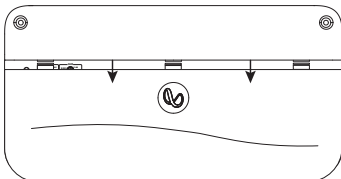

2. Remove panel cover

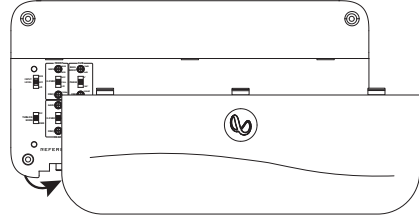

MOUNTING THE AMP

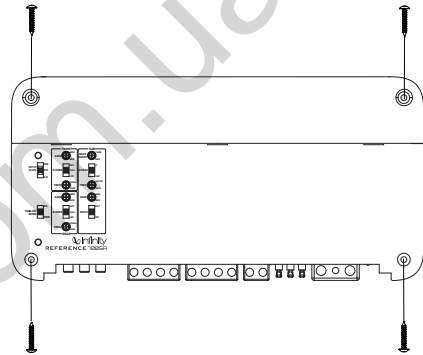

Note: It is recommended that you make all wire connections before mounting the amplifier.

IMPORTANT: Disconnect the vehicle's negative (-) battery terminal before beginning the installation.

- Always wear protective eyewear when using tools.
- Choose a safe mounting location, away from moisture. Check clearances on both sides of a planned mounting surface. Be sure that screws or wires will not puncture brake lines, fuel lines, or wiring harnesses and that wire routing will not interfere with the safe vehicle operation. Use caution when drilling or cutting in the mounting area.
- Choose a location that provides enough air circulation.
- Do not mount the amplifier with the heat sink facing downward, as this interferes with cooling.
- Mount the amplifier so that it will not be damaged by the feet of backseat passengers or shifting cargo in the trunk.

WIRING FOR POWER AND GROUND

At amplifier:

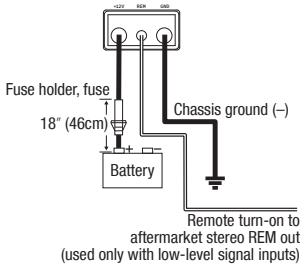

At ground location:

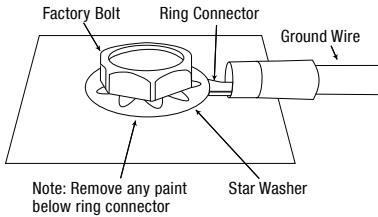

WIRING FOR INPUT SIGNAL

Reference 3004A low-level signals

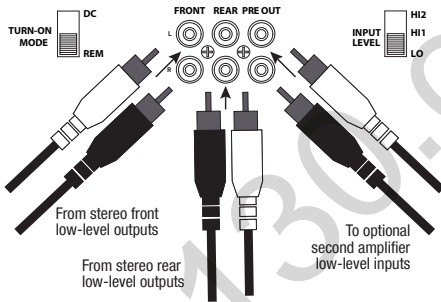

Note: when using low-level signals and remote turn-on lead, set the "TURN-ON MODE" switch to "REM" and the "INPUT LEVEL" switch to "LO".

Reference 7005A low-level signals

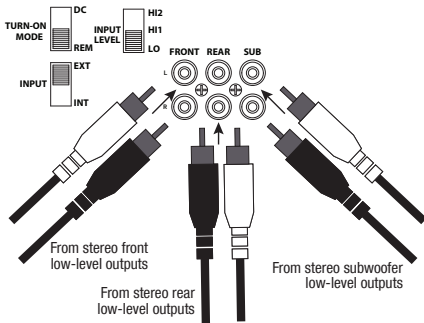

Note: when using low-level signals and remote turn-on lead with the Reference 7005A, set the "TURN-ON MODE" switch to "REM" and the SUB "INPUT" switch to "EXT" and the "INPUT LEVEL" switch to "LO".

Reference 3004A high-level signals

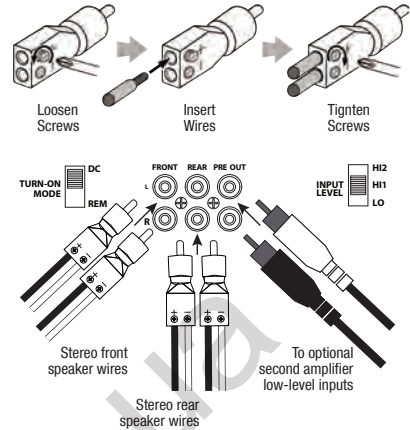

Note: when using high-level signals, set the "TURN-ON MODE" switch to "DC" and the "INPUT LEVEL" switch to "HI1". If no sound plays, change the "INPUT LEVEL" switch to "HI2".

Reference 7005A high-level input signals

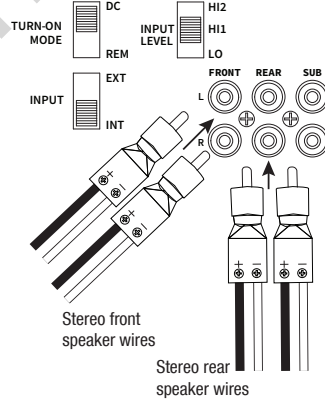

Note: when using high-level signals with the Reference 7005A, set the "TURN-ON MODE" switch to "DC", the SUB "INPUT" switch to "INT", and the "INPUT LEVEL" switch to "HI1". If no sound plays, change the "INPUT LEVEL" switch to "HI2".

WIRING FOR OUTPUT

Reference 3004A 4-channel output (4ohm/2ohm)

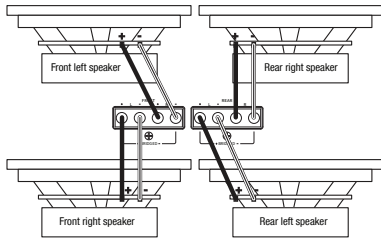

Reference 3004A 3-channel output (Front: 4ohm/2ohm; Rear:4ohm)

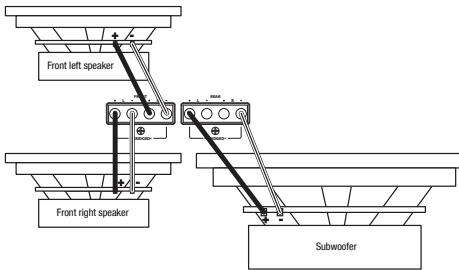

Reference 3004A 2-channel output (4ohm)

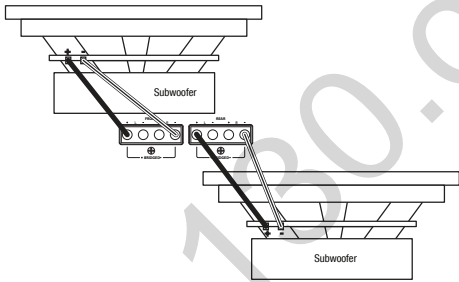

Reference 7005A 5-channel output (4ohm/2ohm)

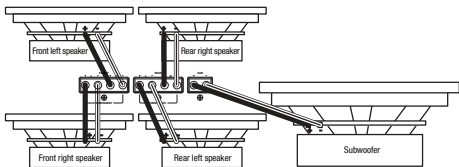

CONNECTING THE REMOTE BASS CONTROLLER (REFERENCE 7005A ONLY)

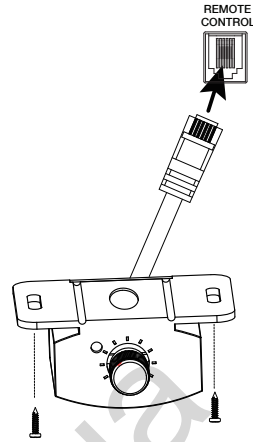

EN

SETTING GAIN, CROSSOVERS, AND BASS BOOST

Setting the gain

1. Start with **GAIN** control set to minimum, and the crossover control rotated midway.
2. For the front and rear channels, choose music you're familiar with. For the subwoofer channel on the Reference 7005A, choose music with substantial bass content.
3. Turn the volume control on your receiver to $\frac{3}{4}$ of its total output.
4. Adjust the **GAIN** control clockwise, listening carefully to the bass output. If you hear distortion, turn the **GAIN** control counterclockwise to decrease the gain.



Selecting the crossover mode

On the front and rear channels, you can select your preferred crossover mode.

Choose HPF to allow only frequencies above a certain point to reach your speakers. Recommended if you're using a subwoofer in your system, as it keeps low base from your full-range speakers.



Choose LPF to allow only frequencies below a certain point to reach your speakers. Recommended if you're bridging the front or rear channels to power a subwoofer.

Choose FULL to allow all frequencies to reach your speakers. Recommended if you're not using a subwoofer in your system.

Note: The crossover mode for the subwoofer channel of the Reference 7005A is low-pass only.

Selecting the crossover frequency

Choose the crossover point to suit listening preferences. Turn the dials to the left to lower the crossover point and to the right to raise the crossover point. Exact crossover settings for coaxial speakers and subwoofers depend on your listening preferences.



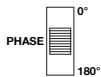

**Selecting the subwoofer phase
(Reference 7005A only)**

Switch the **PHASE** back and forth to determine which setting provides the most clean bass output.



**Selecting the bass boost
(Reference 7005A only)**

Adjust the **BASS-BOOST** control clockwise or counterclockwise to suit your taste.

EN

SPECIFICATIONS

	Reference 3004A	Reference 7005A
Power output @ 4 ohms	75 watts RMS x 4	50 watts RMS x 4, 320 watts x 1
Power output @ 2 ohms	100 watts RMS x 4	75 watts RMS x 4, 500 watts x 1
Power output in bridged mode	200 watts RMS x 2 at 4 ohms	150 watts RMS x 2 at 4 ohms
Frequency response	10-40 K Hz	10-40 K Hz / 10-320 Hz
Crossover frequencies	32-320 Hz variable, 12 dB/ octave	32-320 Hz variable high- and low-pass (front and rear); 32-320 Hz low-pass (subwoofer); 12 dB/ octave
Line-level input sensitivity	200 mVrms – 2.0 Vrms	200 mVrms – 2.0 Vrms
High-level input sensitivity	2.0 Vrms – 20 Vrms	2.0 Vrms – 20 Vrms
Signal-to-noise ratio	>80 dB	>80 dB
THD+N @ rated power	<1%	<1%
Fuse rating	30 x 2	30 x 3
Operating voltage	9~16 V	9~16 V
Dimensions (W x H x D)	12-5/8" x 2-3/16" x 7-1/8" (320 mm x 55.5 mm x 180 mm)	14-3/16" x 2-3/16" x 7-1/8" (360 mm x 56 mm x 180 mm)
Weight	3.15 kg	4.02 kg
Recommended wire gauge	8	4

TROUBLESHOOTING

No audio and POWER INDICATOR is off.

- No voltage at BATT+ and/or REM terminals, or bad or no ground connection. Check voltages at amplifier terminals with VOM.

No audio and PROTECT INDICATOR flashes every 4 seconds.

- DC voltage on amplifier output. Amplifier may need service; see enclosed warranty card for service information.

No audio and PROTECT and POWER INDICATORS flash.

- Voltage less than 9V on BATT+ connection. Check vehicle charging system.

No audio and PROTECT INDICATOR is on.

- Amplifier is overheated. Make sure amplifier cooling is not blocked at mounting location. Or, there may be voltage greater than 16V (or less than 8.5V) on BATT+ connection. Check vehicle charging system.

Amplifier fuse keeps blowing.

- The wiring is connected incorrectly or there is a short circuit. Check wiring connections.

Distorted audio.

- Gain is not set properly. Check setting. Check wires for shorts or grounds. Amplifier or source unit may be defective.

Distorted audio and PROTECT INDICATOR flashes.

- Short circuit in speaker or wire. Remove speaker leads one at a time to locate shorted speaker or wire, and repair.

Music lacks dynamics or "punch".

- Speakers are not connected properly. Check speaker connections for proper polarity.

Engine noise—whining or clicking—in system when the engine is on.

- Amplifier is picking up alternator noise. First, check ground connection on the amplifier – a loose or improper ground is one of the main causes for noise. Turn down gain. Move RCA audio cables away from power wires. Installing an alternator noise filter on power line between battery and alternator might also be necessary.



HARMAN International Industries, Incorporated
8500 Balboa Boulevard,
Northridge, CA 91329 USA
www.infinityspeakers.com

© 2019 HARMAN International Industries, Incorporated. All rights reserved. Infinity is a trademark of HARMAN International Industries, Incorporated, registered in the United States and/or other countries. Features, specifications and appearance are subject to change without notice.

HVAD ER DER I ÆSKEN

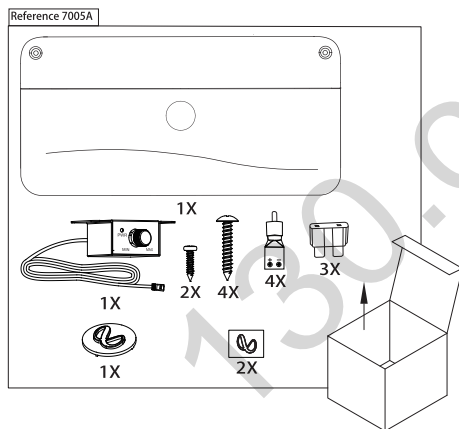
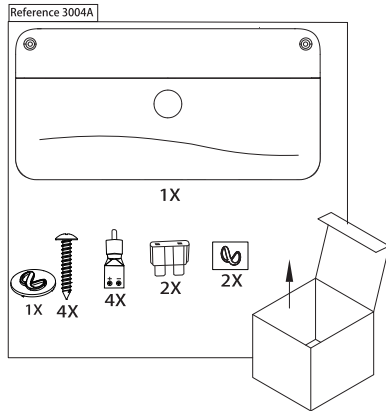

ADGANG TIL TILSLUTNINGER/ KONTROLPANEL

1. Skub paneldækslet ned

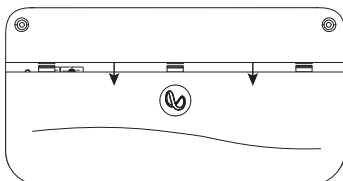

2. Fjern paneldækslet

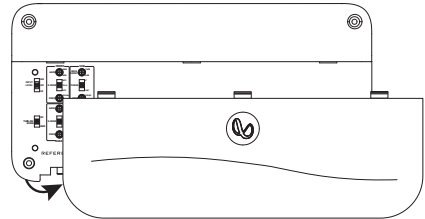

DA

MONTERING AF FORSTÆRKEREN

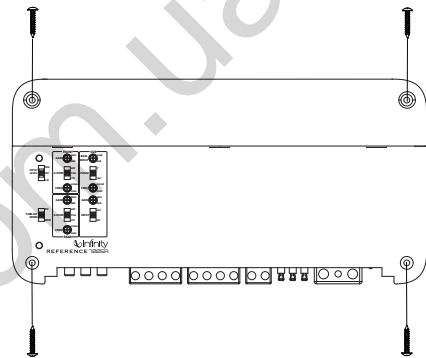

Bemærk: Det anbefales, at du tilslutter alle kabler, inden forstærkeren monteres.

VIGTIGT: Frakobl køretøjets negative (-) batteriterminal, inden du påbegynder installationen.

- Bær altid beskyttelsesbriller, når du bruger værktøj.
- Vælg et sikkert monteringssted, fjernt fra fugtighed. Sørg for, at der er fri plads på begge sider af den planlagte monteringsoverflade. Sørg for, at skruer eller ledninger ikke punkterer bremseslanger, brændstofslanger eller ledninger, og at ledningsføringen ikke påvirker sikker køretøjsoperation. Vær forsigtig, når der bores eller skæres i monteringsområdet.
- Vælg et placeringssted med tilstrækkelig luftcirkulation.
- Monter ikke forstærkeren med varmelederne nedad, da dette forringer køleevnen.
- Monter forstærkeren således, at den ikke bliver beskadiget af passagerernes fødder eller ved indlæsning af bagage i bagagerummet.

LEDNINGER TIL STRØM OG JORD

På forstærkeren:

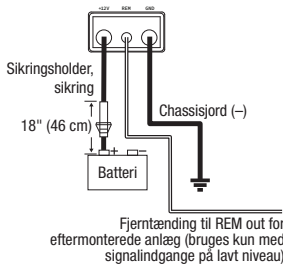

DA

På jordplaceringsstedet:

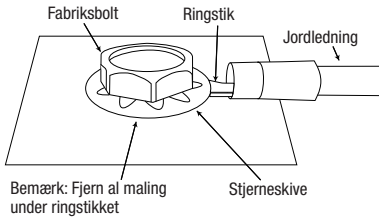

LEDNINGER TIL INDGANGSSIGNAL

Reference 3004A signaler på lavt niveau

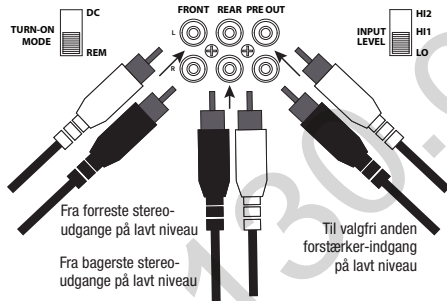

Bemærk: når du bruger signaler på lavt niveau og fjernbetjening, skal du indstille "TURN-ON MODE" kontakten til "REM" og "INPUT LEVEL" kontakten til "LO".

Reference 7005A signaler på lavt niveau

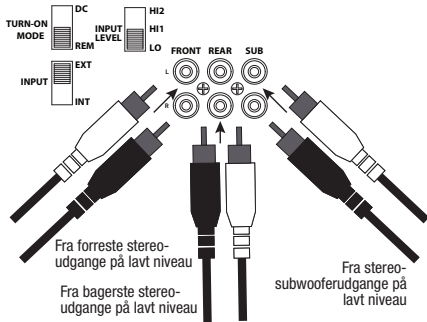

Bemærk: når du bruger signaler på lavt niveau og fjernbetjening med Reference 7005A, skal du indstille "TURN-ON MODE" kontakten til "REM" og SUB "INPUT" kontakten til "EXT" og "INPUT LEVEL" kontakten "LO".

Reference 3004A signaler på højt niveau

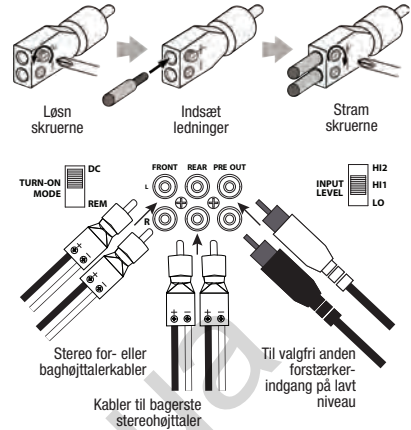

Bemærk: når bruger signaler på højt niveau, skal du indstille "TURN-ON MODE" kontakten til "DC" og "INPUT LEVEL" kontakten til "HI1". Hvis der ikke afspilles nogen lyd, skift "INPUT LEVEL" kontakten til "HI2".

Reference 7005A indgangssignaler på højt niveau

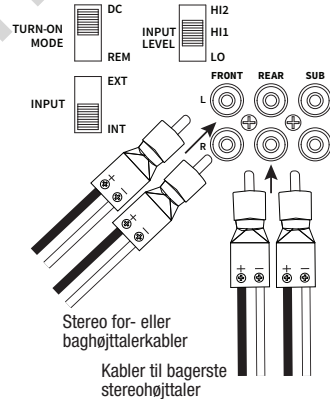

Bemærk: når du bruger signaler på højt niveau Reference 7005A, indstil "TURN-ON MODE" kontakten til "DC", SUB "INPUT" kontakten til "INT", og "INPUT LEVEL" kontakten til "HI1". Hvis der ikke afspilles nogen lyd, skift "INPUT LEVEL" kontakten til "HI2".

LEDNINGER TIL UDGANGE

Reference 3004A 4-kanalindgang (4 ohm/2 ohm)

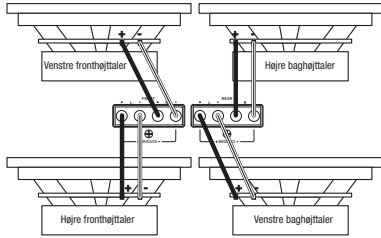

Reference 3004A 3-kanalindgang (Front: 4 ohm/2 ohm; Bag: 4 ohm)

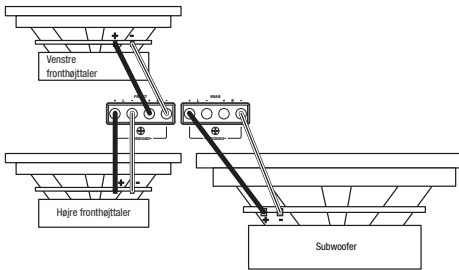

Reference 3004A 2-kanalindgang (4 ohm)

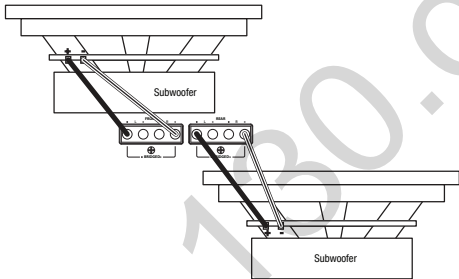

Reference 7005A 5-kanalindgang (4 ohm/2 ohm)

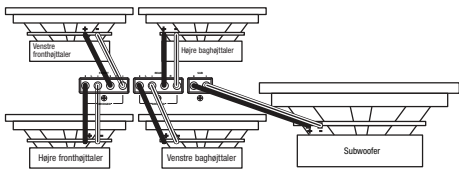

TILSLUTNING AF FJERNBETJENING AF BASSEN (KUN REFERENCE 7005A)

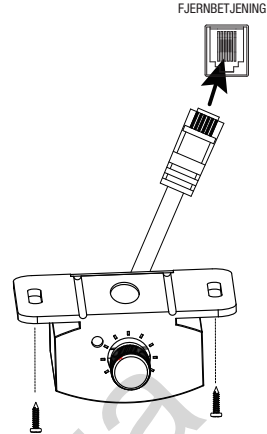

DA

INDSTILLING AF FORSTÆRKNING, CROSSOVERS OG BAS-FORSTÆRKNING

Indstilling af forstærkning

1. Start med **GAIN** forstærkningskontrol indstillet til minimum, og crossover-kontrol roteret halvvejs.
2. Vælg velkendt musik til de forreste og bagerste kanaler. For musik i subwoofer på Reference 7005A skal du vælge musik med stort basindhold.
3. Drej lydstyrkekontrollen på din receiver til $\frac{3}{4}$ af dens samlede output.
4. Juster **GAIN** forstærkerkontrollen med uret, og lyt nøje til basudgangen. Hvis du hører forvrængning, drej **GAIN** forstærkerkontrollen mod uret for at mindske forstærkningen.



Valg af crossover-tilstand

På de forreste og bagerste kanaler kan du vælge din foretrukne crossover-tilstand.

Vælg HPF for kun at tillade frekvenser over et bestemt punkt at nå dine højttalere. Anbefales, hvis du bruger en subwoofer i dit system, da det holder dyb bas fra dine fuldskala-højttalere.

Vælg LPF for kun at tillade frekvenser under et bestemt punkt at nå dine højttalere. Anbefales, hvis du vil bygge en bro mellem de forreste eller bageste kanaler for at skabe en subwoofer.

Vælg FULL for at tillade alle frekvenser at nå dine højttalere. Anbefales, hvis du ikke bruger en subwoofer i dit system.

Bemærk: Crossover-tilstanden til subwooferkanalen i Reference 7005A er kun lavpas.

Valg af crossover-frekvens

Vælg crossover-punktet, der passer til dine præferencer. Drej knapperne til venstre for at sænke crossover-punktet og til højre for at hæve crossover-punktet. De nøjagtige indstillinger af crossover for koaksiale højttalere og subwoofere afhænger af dine lyttepræferencer.



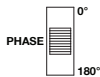

Valg af subwoofer-fasen (Kun Reference 7005A)

Skift PHASE frem og tilbage for at bestemme hvilken indstilling, der giver den reneeste basgengivelse.



Valg af bas-forstærkning (Kun Reference 7005A)

Justér BASS-BOOST betjeningen med uret eller mod uret for at tilpasse til din smag.

PROBLEMLØSNING

Ingen lyd og STRØMINDIKATOREN er slukket.

- Ingen spænding ved BATT+ og/eller REM-terminalerne, eller dårlig eller ingen jordforbindelse. Kontroller spændingen ved forstærkerens terminaler med et voltmeter.

Ingen lyd og BESKYTTELSESINDIKATOREN blinker hver 4. sekund.

- DC-spænding ved forstærkerudgang. Forstærkeren skal muligvis efterses; se vedlagte garantibeviskort for oplysninger vedrørende service.

Ingen lyd og BESKYTTELSES- og STRØMINDIKATORERNE blinker.

- Spændingen er mindre end 9 V ved BATT+ forbindelsen. Kontroller køretøjets opladesystem.

Ingen lyd og BESKYTTELSESINDIKATOREN er tændt.

- Forstærkeren er overophedet. Sørg for, at forstærkerens koelementer ikke er blokeret på monteringsstedet. Eller, der er muligvis en spænding, som er større end 16 V (eller mindre end 8,5 V) på BATT+ forbindelsen. Kontroller køretøjets opladesystem.

Forstærkerens sikring springer hele tiden.

- Kabelføringen er tilsluttet forkert, eller der er en kortslutning. Kontrollér kabelforbindelserne.

Forvrænget lyd.

- Forstærkningen ("Gain") er ikke indstillet korrekt. Kontroller indstillingen. Kontroller ledningerne for kortslutninger eller jordforbindelse. Forstærkeren eller kildeenhed er muligvis defekt.

Forvrænget lyd og BESKYTTELSESINDIKATOREN blinker.

- Kortslutning i højttaleren eller kablerne. Fjern højttalerkablerne én efter én for at finde den kortsluttede højttaler eller kabel, og udfør reparation.

Musikken mangler dynamik eller "punch".

- Højttalerne er ikke tilsluttet korrekt. Kontroller højttalerstikkene for korrekt polaritet.

Motorstøj—hylen eller klik—i systemet, når motoren er i gang.

- Forstærkeren opfanger støj fra generatoren. Kontroller jordforbindelsen på forstærkeren, da en los eller forkert jordforbindelse er en af hovedårsagerne til støj. Skru ned for forstærkningen. Flyt RCA-lydkablerne væk fra strømkabler. Det kan være nødvendigt at installere et filter for generatorstøj på imellem batteriet og generatoren.

SPECIFIKATIONER

DA

	Reference 3004A	Reference 7005A
Effektudgang @ 4 ohm	75 watt RMS x 4	50 watt RMS x 4, 320 watts x 1
Effektudgang @ 2 ohm	100 watt RMS x 4	75 watt RMS x 4, 500 watts x 1
Strømodgang i brobygningstilstand	200 watt RMS x 2 ved 4 ohm	150 watt RMS x 2 ved 4 ohm
Frekvensområde	10-40 K Hz	10-40 K Hz / 10-320 Hz
Crossover-frekvenser:	32-320 Hz variabel, 12 dB/ oktav	32-320 Hz variabel høj- og lavpas (foran og bag); 32-320 Hz lavpas (subwoofer); 12 dB/oktav
Line-niveau indgangsfølsomhed:	200 mVrms – 2,0 Vrms	200 mVrms – 2,0 Vrms
Høj-level indgangsfølsomhed:	2,0 mVrms – 20 Vrms	2,0 mVrms – 20 Vrms
Signal til støj-forhold	>80 dB	>80 dB
THD+N @ nominal effekt	<1%	<1%
Sikringskapacitet	30 x 2	30 x 3
Driftsspænding	9–16 V	9–16 V
Mål (B x H x D):	12-5/8" x 2-3/16" x 7-1/8" (320 mm x 55,5 mm x 180 mm)	14-3/16" x 2-3/16" x 7-1/8" (360 mm x 56 mm x 180 mm)
Vægt	3.15 kg	4.02 kg
Anbefalede kabelmål	8	4



HARMAN International Industries,
Incorporated 8500 Balboa Boulevard,
Northridge, CA 91329 USA
www.infinityspeakers.com

© 2019 HARMAN International Industries, Incorporated. Alle rettigheder forbeholdes. Infinity er et varemærke tilhørende Harman International Industries, Incorporated, registreret i USA og/eller andre lande. Funktioner, specifikationer og udseende kan ændres uden varsel.

VERPACKUNGSIHALT

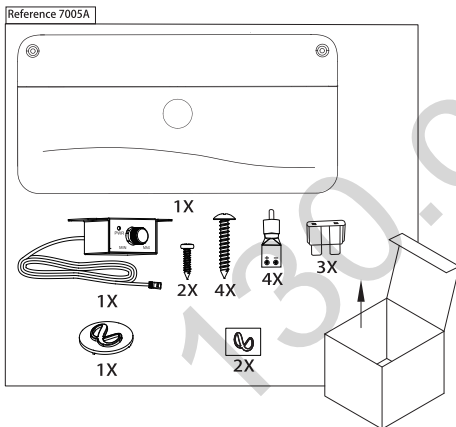
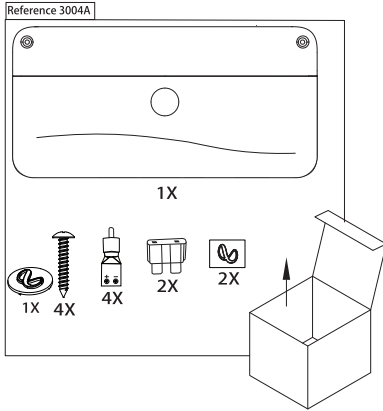

ZUGANG ZU ANSCHLÜSSEN UND BEDIENFELD

1. Abdeckung nach unten schieben

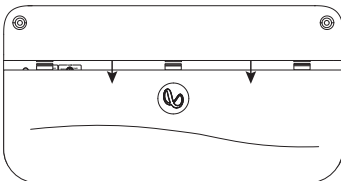

2. Abdeckung entfernen

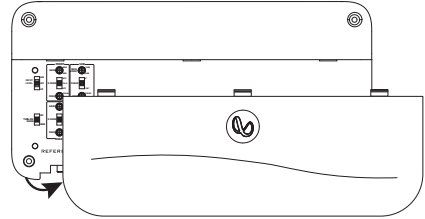

DE

MONTAGE DES VERSTÄRKERS

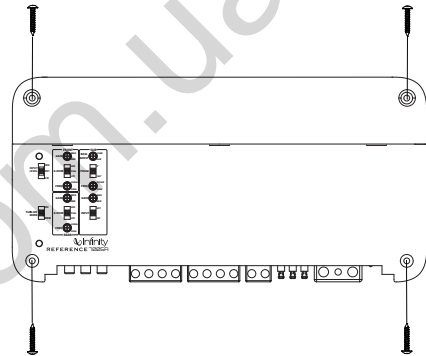

Hinweis: Es wird empfohlen, alle Kabelverbindungen herzustellen, bevor der Verstärker montiert wird.

WICHTIG: Trenne den Minus(-)-Pol der Fahrzeugbatterie vor Beginn der Installation.

- Trage bei der Arbeit mit Werkzeugen immer eine Schutzbrille.
- Wähle einen sicheren und trockenen, vor Feuchtigkeit geschützten Montagestandort. Prüfe die Abstände auf beiden Seiten der vorgesehenen Montagefläche. Achte darauf, dass Schrauben oder Kabel keine Bremsleitungen, Kraftstoffleitungen oder Kabelbäume durchstechen und dass die Kabelführung nicht den sicheren Betrieb des Fahrzeugs beeinträchtigt. Gehe beim Bohren oder Schneiden im Montagebereich vorsichtig vor.
- Wähle einen Ort, der für eine ausreichende Luftzirkulation sorgt.
- Montiere den Verstärker nicht mit dem Kühlkörper nach unten, da dies die Konvektionskühlung beeinträchtigt.
- Montiere den Verstärker so, dass er nicht durch die Füße der Mitfahrer auf dem Rücksitz oder durch ein Verschieben der Ladung im Kofferraum beschädigt werden kann.

VERKABELUNG FÜR STROMVERSORUNG UND MASSE

Am Verstärker:

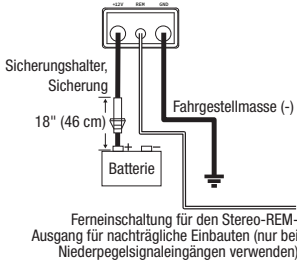

Hinweis: Wenn Niederpegelsignale und die Fernsteuerungs-Einschaltleitung beim Reference 7005A verwendet werden, muss der Schalter „TURN-ON MODE“ auf „REM“, der SUB-Schalter „INPUT“ auf „EXT“ und der Schalter „INPUT LEVEL“ auf „LO“ gesetzt werden.

Reference 3004A Hochpegelsignale

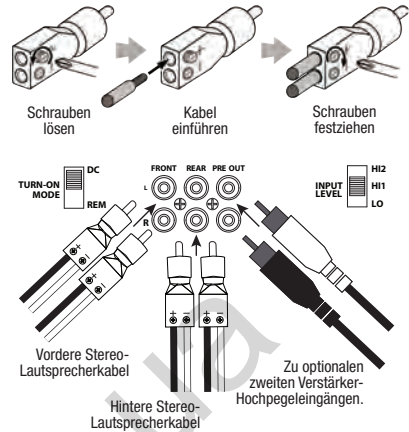

Hinweis: Wenn Hochpegelsignale verwendet werden, muss der Schalter „TURN-ON MODE“ auf „DC“ und der Schalter „INPUT LEVEL“ auf „HI1“ gesetzt werden. Wenn kein Ton wiedergegeben wird, muss der Schalter „INPUT LEVEL“ auf „HI2“ gesetzt werden.

DE An Masseanschluss:

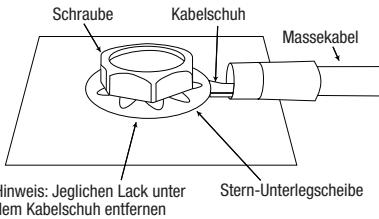

VERKABELUNG FÜR EINGANGSSIGNAL

Reference 3004A Niederpegelsignale

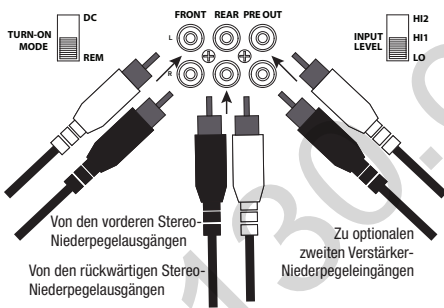

Hinweis: Wenn Niederpegelsignale und die Fernsteuerungs-Einschaltleitung verwendet werden, muss der Schalter „TURN-ON MODE“ auf „REM“ und der Schalter „INPUT LEVEL“ auf „LO“ gesetzt werden.

Reference 7005 a Niederpegelsignale

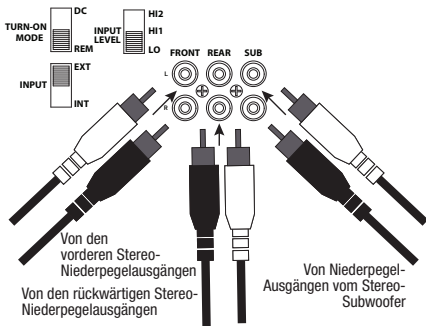

Reference 7005A Hochpegel-Eingangssignale

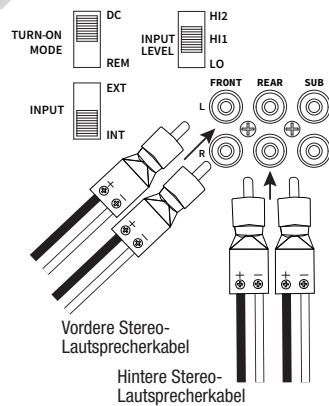

Hinweis: Wenn Hochpegelsignale beim Reference 7005A verwendet werden, muss der Schalter „TURN-ON MODE“ auf „DC“, der SUB-Schalter „INPUT“ auf „INT“ und der Schalter „INPUT LEVEL“ auf „HI1“ gesetzt werden. Wenn kein Ton wiedergegeben wird, muss der Schalter „INPUT LEVEL“ auf „HI2“ gesetzt werden.

VERKABELUNG FÜR AUSGANG

Reference 3004A 4-Kanal-Ausgang (4 Ohm/2 Ohm)

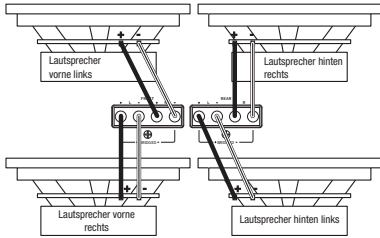

Reference 3004A 3-Kanal-Ausgang (Front: 4 Ohm/2 Ohm; Rückseite: 4 Ohm)

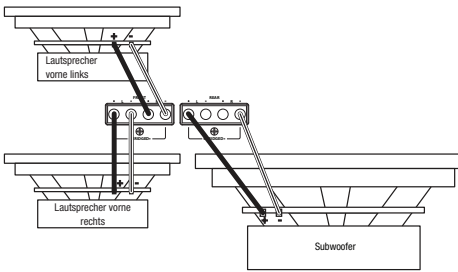

Reference 3004A 2-Kanal-Ausgang (4 Ohm)

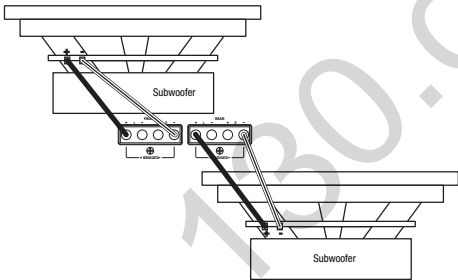

Reference 7005 a 5-Kanal-Ausgang (4 Ohm/2 Ohm)

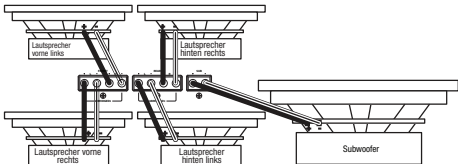

ANSCHLUSS DER BASS-FERNSTEUERUNG (NUR REFERENCE 7005A)

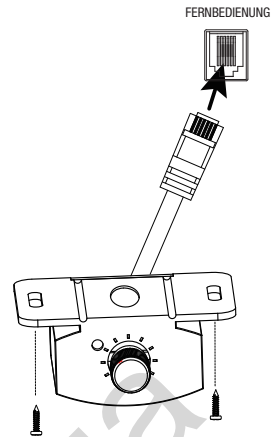

DE

EINSTELLEN VON VORVERSTÄRKUNG, FREQUENZWEICHEN UND BASSVERSTÄRKUNG

Einstellen der Vorverstärkung

1. Beginne mit der Minimaleinstellung des Reglers **GAIN**, während die Frequenzweiche in Mittelstellung steht.
2. Wähle für die vorderen und hinteren Kanäle Musik, mit der du vertraut bist. Wähle für den Subwoofer-Kanal des Reference 7005A Musik mit kräftigem Bassanteil.
3. Drehe den Lautstärkeregler deines Receivers auf $\frac{3}{4}$ der Gesamtleistung.
4. Drehe den Regler **GAIN** im Uhrzeigersinn, während du gleichzeitig auf die Bässe hörst. Falls du eine Verzerrung hörst, drehe den Regler **GAIN** gegen den Uhrzeigersinn, um die Vorverstärkung zu senken.



Auswahl des Frequenzweichenmodus

Auf den vorderen und hinteren Kanälen kann der gewünschte Frequenzweichenmodus ausgewählt werden.

Wähle HPF, um nur Frequenzen ab einem bestimmten Wert zuzulassen, die deine Lautsprecher erreichen. Dies wird empfohlen, wenn ein Subwoofer in deinem System integriert ist, da er die Wiedergabe der tiefen Bässe übernimmt und sie nicht an die Breitbandlautsprecher weitergeleitet werden.



Wähle LPF, um nur Frequenzen unter einem bestimmten Wert zuzulassen, die deine Lautsprecher erreichen. Dies wird empfohlen, wenn die vorderen oder hinteren Kanäle überbrückt sind, um einen Subwoofer zu betreiben.

Wähle FULL, damit alle Frequenzen deine Lautsprecher erreichen. Dies wird empfohlen, wenn kein Subwoofer im System integriert ist.

Hinweis: Der Frequenzweichenmodus für den Subwoofer-Kanal des Reference 7005A ist ein reiner Tiefpass.



Auswahl der Weichenfrequenz

Wähle den Übergangspunkt entsprechend den Hörpräferenzen. Drehe die Regler nach links, um den Crossover-Punkt zu verringern bzw. nach rechts, um ihn zu erhöhen. Die genauen Frequenzweicheneinstellungen für Koaxial-Lautsprecher und Subwoofer sind von deinen persönlichen Vorlieben abhängig.

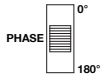

Auswahl der Subwoofer-Phase (nur Reference 7005A)

Wechsle PHASE zwischen 0 und 180 Grad, um festzustellen, welche Einstellung die klarsten Bässe liefert.



Auswahl der Bassverstärkung (nur Reference 7005A)

Passe den Regler BASS-BOOST nach deinen Wünschen im Uhrzeigersinn oder gegen diesen an.

DE

TECHNISCHE DATEN

	Reference 3004 a	Reference 7005 a
Nennleistung bei 4 Ohm	75 Watt RMS x 4	50 Watt RMS x 4 + 320 Watt RMS x 1
Nennleistung bei 2 Ohm	100 Watt RMS x 4	75 Watt RMS x 4 + 500 Watt RMS x 1
Ausgangsleistung im gebrückten Modus	200 Watt RMS x 2 mit 4 Ohm	150 Watt RMS x 2 mit 4 Ohm
Frequenzbereich	10–40 kHz	10–40 kHz / 10–320 Hz
Trennfrequenzen	32–320 Hz (variabel), 12 dB/Oktave	32–320 Hz variabler Hoch- und Tiefpass (vorne und hinten); 32–320 Hz Tiefpass (Subwoofer); 12 dB/Oktave
Eingangsempfindlichkeit für Line-Pegel:	200 mV RMS – 2,0 V RMS	200 mV RMS – 2,0 V RMS
Eingangsempfindlichkeit für Hochpegel:	2,0–20 V RMS	2,0–20 V RMS
Rauschabstand	>80 dB	>80 dB
THD+N bei Nennleistung	< 1 %	< 1 %
Sicherungswert	30 A x 2	30 A x 3
Betriebsspannung	9–16 V	9–16 V
Abmessungen (B x H x T):	12-5/8" x 2-3/16" x 7-1/8" (320 mm x 55,5 mm x 180 mm)	14-3/16" x 2-3/16" x 7-1/8" (360 mm x 56 mm x 180 mm)
Gewicht	3.15 kg	4.02 kg
Empfohlener Kabelquerschnitt	8	4

FEHLERBEHEBUNG

Kein Ton und die NETZSTROMANZEIGE ist aus.

- Keine oder unzureichende Spannung an den BATT+- und/oder REM-Anschlüssen oder kein Masse-Anschluss. Überprüfe die Spannung an den Verstärkeranschlüssen mit einem Spannungsmessgerät.

Kein Ton und die SCHUTZANZEIGE blinkt alle 4 Sekunden.

- DC-Spannung am Verstärker-Ausgang. Der Verstärker muss eventuell repariert werden. Entnehme die Informationen zu den Reparaturmöglichkeiten dem beigefügten Garantieschein.

Kein Ton und SCHUTZ- und NETZSTROMANZEIGE blinken.

- Stromspannung unter 9 V am BATT+-Anschluss. Überprüfe das Batterieladesystem des Fahrzeugs.

Kein Ton und die SCHUTZANZEIGE leuchtet.

- Der Verstärker ist überhitzt. Stelle sicher, dass die Kühlung des Verstärkers am aufgestellten Standort genügend Kühlluft bekommt. Möglicherweise übersteigt die Spannung am BATT+-Anschluss 16 V (oder liegt unter 8,5 V). Überprüfe das Batterieladesystem des Fahrzeugs.

Die Sicherung des Verstärkers brennt immer wieder durch.

- Die Verkabelung ist falsch angeschlossen oder ein Kurzschluss tritt auf. Überprüfe die Kabelanschlüsse.

Verzerrter Ton.

- Die Eingangsempfindlichkeit (Gain) ist falsch eingestellt. Einstellung prüfen. Vergewissere dich, dass keine Kurz- oder Masseschlüsse aufgetreten sind. Der Verstärker oder das Quellgerät ist eventuell defekt.

Verzerrter Ton und die SCHUTZANZEIGE blinkt.

- Kurzschluss im Lautsprecher oder in der Verkabelung. Entferne die Lautsprecheranschlüsse einzeln und nacheinander, um die betroffene Komponente (Lautsprecher oder Kabel) zu identifizieren, und repariere sie.

Die Musik hat keine Dynamik, oder keinen „Punch“.

- Die Lautsprecher sind nicht richtig angeschlossen. Überprüfe die Anschlüsse und die entsprechenden Polaritäten.

Motorgeräusch – „Jaulen“ oder „Knacken“ – im System, wenn der Motor läuft.

- Der Verstärker übernimmt die Geräusche der Lichtmaschine. Überprüfe die Masse-Anschlüsse am Verstärker - ein lockerer oder fehlerhafter Masse-Anschluss ist einer der häufigsten Gründe für externe Geräusche. Drehe die Vorverstärkung (Gain) herunter. Entferne die Cinch-Audiokabel von den Netzstromkabeln. Die Installation eines Filters zur Entfernung von Lichtmaschinengeräuschen am Netzkabel zwischen der Batterie und der Lichtmaschine ist evtl. auch nötig.



HARMAN International Industries, Incorporated 8500 Balboa Boulevard, Northridge, CA 91329 USA www.infinityspeakers.com

© 2019 HARMAN International Industries, Incorporated. Alle Rechte vorbehalten. Infinity ist ein Warenzeichen von HARMAN International Industries, Incorporated, registriert in den Vereinigten Staaten und/oder anderen Ländern. Änderungen an Merkmalen, Spezifikationen und Aussehen können ohne vorherige Ankündigung erfolgen.

CONTENIDO DE LA CAJA

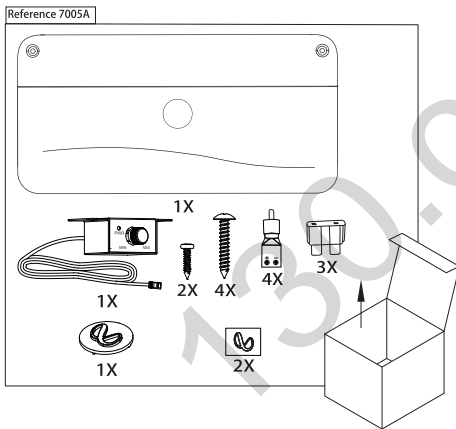
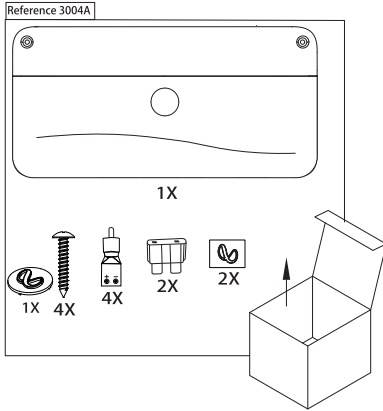

ACCESO A LOS CONECTORES Y EL PANEL DE CONTROL

1. Desliza la tapa del panel para quitarla

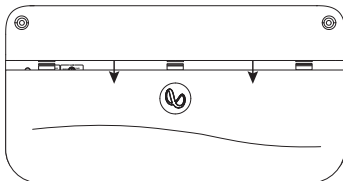

2. Quita la cubierta del panel

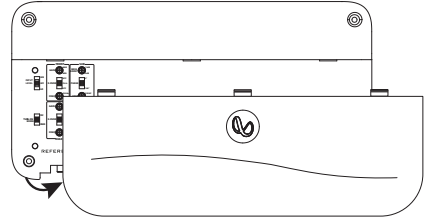

MONTAJE DEL AMPLIFICADOR

ES

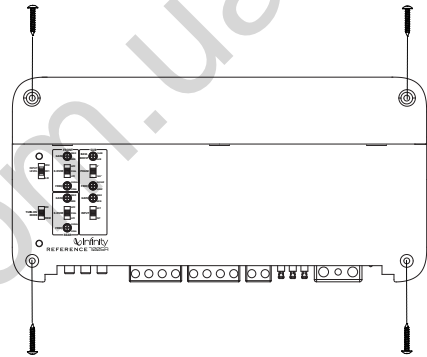

Nota: se recomienda realizar todas las conexiones de cables antes de montar el amplificador.

IMPORTANTE: desconecta el terminal negativo (-) de la batería del vehículo antes de empezar la instalación.

- Utiliza protección ocular siempre que utilices herramientas.
- Elige una ubicación de montaje segura, alejada de la humedad. Comprueba los espacios libres a ambos lados de la superficie de montaje planificada. Asegúrate de que los tornillos o cables no pinchen las líneas de freno, las líneas de combustible ni los mazos de cables y que el tendido de los cables no interfiera en el funcionamiento seguro del vehículo. Actúa con precaución al taladrar o cortar en el área de montaje.
- Elige una ubicación con circulación de aire suficiente.
- No montes el amplificador con el sumidero de calor mirando hacia abajo, ya que esto interfiere con la refrigeración.
- Monta el amplificador de forma que no se dañe con los pies de los pasajeros de los asientos traseros ni con el movimiento de las cargas en el maletero.

CABLEADO DE ALIMENTACIÓN Y CONEXIÓN A TIERRA

En el amplificador:

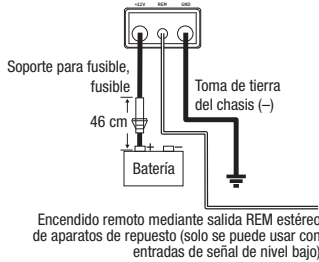

En la ubicación de toma de tierra:

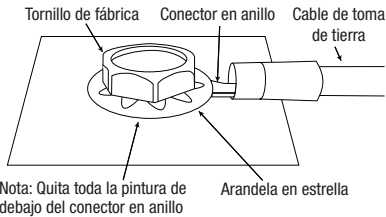

Nota: si vas a utilizar señales de nivel bajo y un cabo de encendido remoto con el Reference 7005A, pon el interruptor "TURN-ON MODE" en "REM", el interruptor SUB "INPUT" en "EXT" y el interruptor "INPUT LEVEL" en "LO".

Señales de nivel alto de Reference 3004A

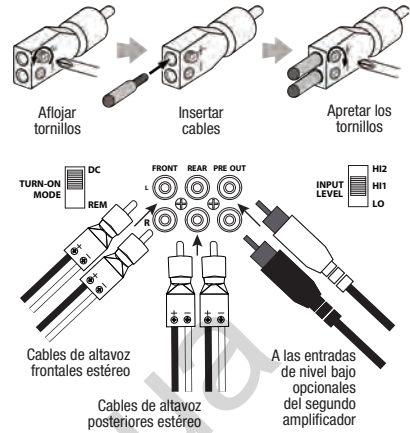

Nota: si vas a utilizar señales de nivel alto, pon el interruptor "TURN-ON MODE" en "DC" y el interruptor "INPUT LEVEL" en "HI1". Si no se reproduce ningún sonido, cambia el interruptor "INPUT LEVEL" a "HI2".

CABLEADO DE LA SEÑAL DE ENTRADA

Señales de nivel bajo de Reference 3004A

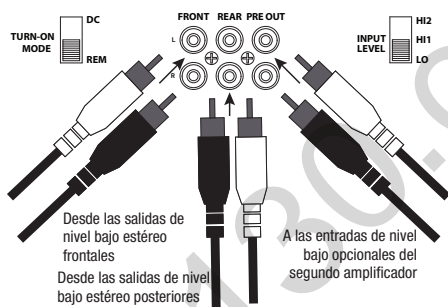

Nota: si vas a utilizar señales de nivel bajo y un cabo de encendido remoto, pon el interruptor "TURN-ON MODE" en la posición "REM" y el interruptor "INPUT LEVEL" en "LO".

Señales de nivel alto de Reference 7005A

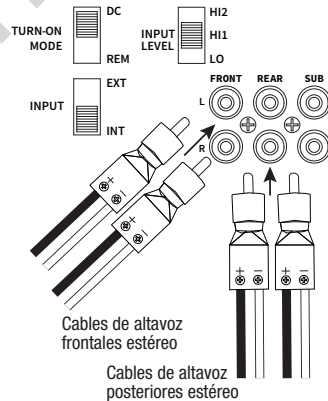

Nota: si vas a utilizar señales de nivel alto con Reference 7005A, pon el interruptor "TURN-ON MODE" en "DC", el interruptor SUB "INPUT" en "INT" y el interruptor "INPUT LEVEL" en "HI1". Si no se reproduce ningún sonido, cambia el interruptor "INPUT LEVEL" a "HI2".

Señales de nivel bajo de Reference 7005A

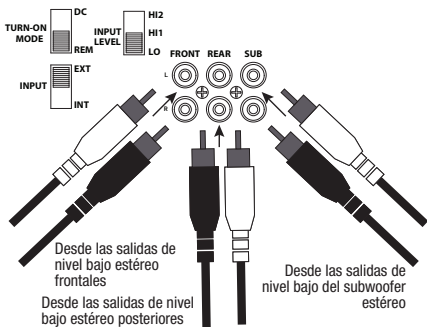

CABLEADO DE SALIDA

Salida de 4 canales de Reference 3004A (4 Ohm/2 Ohm)

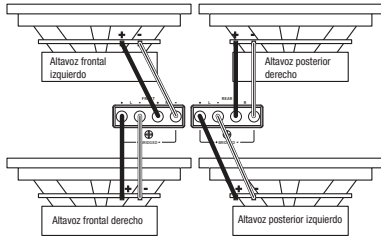

Salida de 3 canales de Reference 3004A (Frontal: 4 Ohm/2 Ohm; Posterior: 4 Ohm)

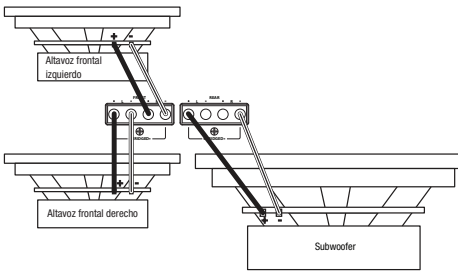

Salida de 2 canales de Reference 3004A (4 Ohm)

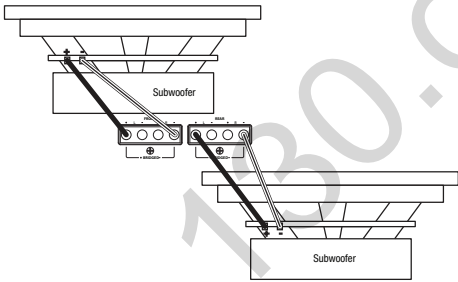

Salida de 5 canales de Reference 7005A (4 Ohm/2 Ohm)

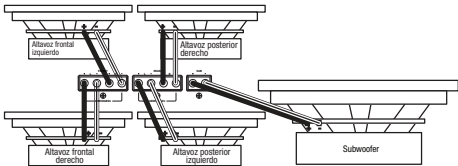

CONECTAR EL CONTROLADOR REMOTO DE BAJOS (REFERENCE 7005A SOLAMENTE)

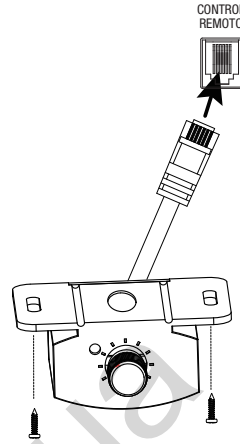

ES

CONFIGURAR LA GANANCIA, LOS CORTES DE FRECUENCIAS Y LA POTENCIACIÓN DE BAJOS (GAIN, CROSSOVER Y BASS BOOST)

Configurar GAIN

1. Empieza con el control **GAIN** en el mínimo y el control de corte de frecuencias girado hasta la mitad.
2. Para los canales frontales y posteriores, elige música que conozcas bien. Para el canal de subwoofer del Reference 7005A, elige música con un contenido sustancial de bajos.
3. Gira el control de volumen del receptor hasta $\frac{3}{4}$ de la salida total.
4. Ajusta el control **GAIN** hacia la derecha, escuchando atentamente a la salida de bajos. Si se oye distorsión, gira el control **GAIN** hacia la izquierda para volver a reducirla.



Seleccionar el modo de corte

En los canales frontal y posterior, puedes seleccionar el modo de corte de frecuencias que prefieras.

Elige HPF para permitir que solo las frecuencias superiores a cierto punto lleguen a los altavoces. Se recomienda si utilizas un subwoofer en el sistema, ya que mantiene la base de los altavoces de gama completa en un nivel bajo.

Elige LPF para permitir que solo las frecuencias superiores a cierto punto lleguen a los altavoces. Recomendado si vas a puentear los canales frontales o posteriores para alimentar un subwoofer.

Elige FULL para permitir que todas las frecuencias lleguen a los altavoces. Recomendado si no utilizas ningún subwoofer en el sistema.

Nota: El modo de corte de frecuencias para el canal de subwoofer del Reference 7005A es solo pasabajos.





Seleccionar la frecuencia de corte

Elige el punto de corte que se ajuste mejor a tus preferencias. Gira los diales hacia la izquierda para reducir el punto de corte y hacia la derecha para aumentarlo. Los ajustes de corte precisos para altavoces coaxiales y subwoofers dependen de las preferencias de escucha de cada persona.

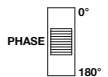

Seleccionar la fase del subwoofer (Reference 7005A solamente)

Alterna el conmutador PHASE entre las dos posiciones para determinar qué ajuste proporciona los bajos más nítidos.



Seleccionar la fase del subwoofer (Reference 7005A solamente)

Ajusta el control BASS-BOOST hacia la derecha o hacia la izquierda a tu gusto.

SOLUCIÓN DE PROBLEMAS

No hay sonido y el indicador POWER (Alimentación) está apagado.

- No hay tensión en los terminales BATT+ y/o REM o la conexión con tierra es defectuosa o inexistente. Comprueba las tensiones en los terminales del amplificador con VOM.

No hay sonido y el indicador PROTECT (Protección) parpadea cada 4 segundos.

- Tensión de CC en la salida del amplificador. Es posible que sea necesario reparar el amplificador. Consulta la información de servicio en la tarjeta de garantía incluida.

No hay sonido y los indicadores PROTECT (Proteger) y POWER (Alimentación) parpadean.

- La tensión en el conector BATT+ es menor que 9 V. Comprueba el sistema de carga del vehículo.

No hay sonido y el indicador PROTECT (Protección) está encendido.

- El amplificador está sobrecalentado. Comprueba que la refrigeración del amplificador no esté bloqueada en el lugar de montaje. También es posible que la tensión sea mayor que 16 V (o menor que 8,5 V) en el conector BATT+. Comprueba el sistema de carga del vehículo.

El fusible del amplificador se quema continuamente.

- El cableado está mal conectado o hay un cortocircuito. Comprueba las conexiones de los cables.

Audio distorsionado.

- La ganancia no está bien configurada. Comprueba el ajuste. Comprueba que no haya ningún cortocircuito ni derivación a tierra en los cables. Es posible que el amplificador o la unidad de fuente estén dañados.

Audio distorsionado y el indicador PROTECT (Proteger) parpadea.

- Cortocircuito en el altavoz o el cable. Quita los latiguillos del altavoz de uno en uno para localizar el cable o el altavoz cortocircuitado y repáralo.

La música carece de dinámica o "pegada".

- Los altavoces no están bien conectados. Comprueba la polaridad de las conexiones de los altavoces.

Ruido del motor (chirridos o chasquidos) en el sistema cuando el motor está en marcha.

- El amplificador capta ruido del alternador. Comprueba las conexiones del amplificador, ya que una toma de tierra floja o deficiente es una de las causas principales del ruido ajeno en el sistema de audio. Reduce la ganancia. Aleja los cables de audio RCA de los cables de alimentación. También puede ser necesario instalar un filtro para el ruido del alternador en la línea de alimentación entre la batería y el alternador.

ES ESPECIFICACIONES

	Reference 3004A	Reference 7005A
Salida de potencia a 4 Ohm	75 W RMS x 4	50 W RMS x 4, 320 W x 1
Salida de potencia a 2 Ohm	100 W RMS x 4	75 W RMS x 4, 500 W x 1
Salida de potencia en modo puentado	200 W RMS x 2 a 4 Ohm	150 W RMS x 2 a 4 Ohm
Intervalo de frecuencias	10 - 40 KHz	10 - 40 KHz/ 10 - 320 Hz
Frecuencias de corte	32 - 320 Hz variable, 12 dB/ octava	32 - 320 Hz variable pasaaltos y pasabajos (frontal y posterior); 32 - 320 Hz pasabajos (subwoofer); 12 dB/ octava
Sensibilidad de las entradas de nivel de línea	200 mV rms - 2,0 V rms	200 mV rms - 2,0 V rms
Sensibilidad de las entradas de nivel alto	2,0 V rms - 20 V rms	2,0 V rms - 20 V rms
Relación señal-ruido	>80 dB	>80 dB
THD+N a potencia nominal	<1%	<1%
Valor nominal del fusible	30 x 2	30 x 3
Tensión de funcionamiento	9 ~ 16 V	9 ~ 16 V
Dimensiones (Ancho x Alto x Profundidad):	320 mm x 55,5 mm x 180 mm	360 mm x 56 mm x 180 mm
Peso	3.15 kg	4.02 kg
Calibre de cable recomendado	8	4



HARMAN International Industries, Incorporated 8500 Balboa Boulevard, Northridge, CA 91329 EE.UU. www.infinityspeakers.com

© 2019 HARMAN International Industries, Incorporated. Todos los derechos reservados.

Infinity es una marca comercial de HARMAN International Industries, Incorporated, registrada en los Estados Unidos u otros países. Las funciones, las especificaciones y el diseño del producto están sujetos a cambios sin previo aviso.

PAKKAUKSEN SISÄLTÖ

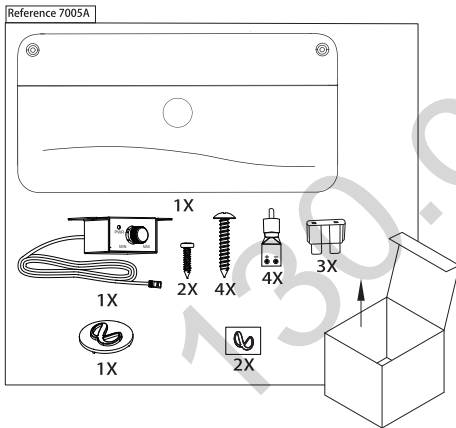
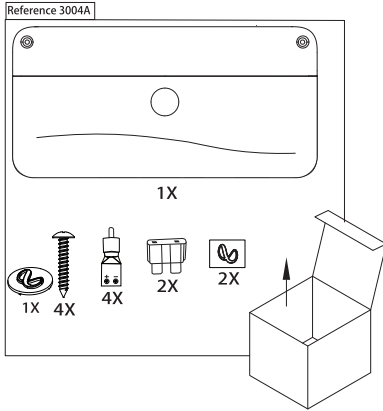

LIITTIMIIN / OHJAUSPANEELIIN PÄÄSY

1. Liu'uta paneelin kansi alas

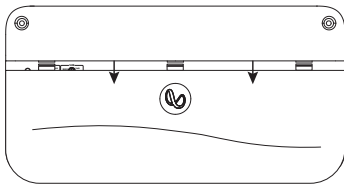

2. Poista paneelin kansi

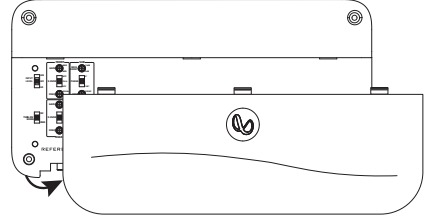

VAHVISTIMEN ASENTAMINEN

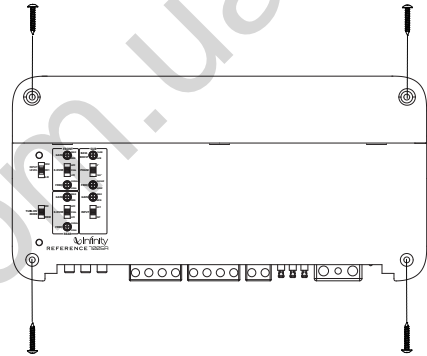

FI

Huomaa: On suositeltavaa tehdä kaikki johtoliitännät ennen vahvistimen kiinnittämistä.

TÄRKEÄÄ: Irrota auton akun negatiivinen (-) napa ennen asennuksen aloittamista.

- Käytä aina suojalaseja työkaluja käyttäessäsi.
- Valitse turvallinen ja kosteudelta suojattu kiinnityskohta. Tarkista, että kiinnityspinnan molemmilla puolilla on riittävästi vapaata tilaa. Varmista, että ruuvit tai johtimet eivät riko jarruputkia, polttoaineputkia tai johdotuksia, ja että niiden reititys ei häiritse ajoneuvon turvallista käyttöä. Noudata varovaisuutta, kun poraat tai leikkaat asennusalueita.
- Valitse sijainti, jossa on riittävästi ilmankiertoa.
- Älä kiinnitä vahvistinta jäähdytysrivat alas päin, sillä tämä häiritsee jäähdytystä.
- Kiinnitä vahvistin niin, että takapenkin matkustajien jalat tai takakantissa liikkuva lasti eivät voi vahingoittaa sitä.

JOHDOTUS, VIRTA JA MAA

Vahvistimessa:

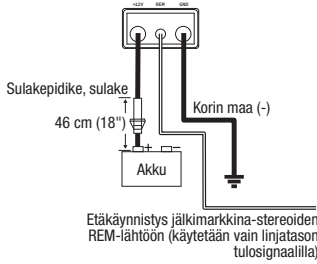

Maassa:

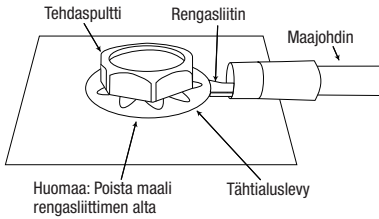

Huomaa: Kun käytät linjatason signaaleja ja herätevirtajohtoa Reference 7005A:n kanssa, aseta "TURN-ON MODE"-kytkin "REM"-asettoon ja SUB "INPUT"-kytkin "EXT"-asettoon ja "INPUT LEVEL"-kytkin "LO"-asettoon.

Reference 3004A kaiutintason signaalit

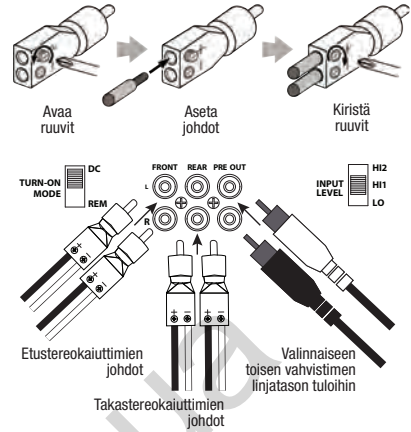

Huomaa: Kun käytät kaiutintason signaaleja, aseta "TURN-ON MODE"-kytkin "DC"-asettoon ja "INPUT LEVEL"-kytkin "HI1"-asettoon. Jos ääntä ei kuulu, vaihda "INPUT LEVEL"-kytkin "HI2"-asettoon.

TULOSIGNAALIN JOHDOTUS

Reference 3004A linjatason signaalit

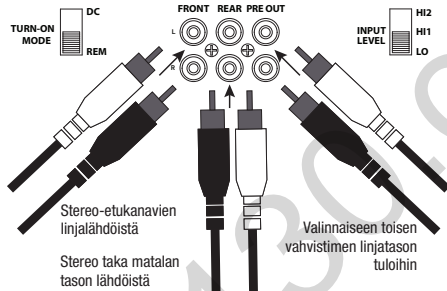

Huomaa: Kun käytät linjatason signaaleja ja herätevirtajohtoa, aseta "TURN-ON MODE"-kytkin "REM"-asettoon ja "INPUT LEVEL"-kytkin "LO"-asettoon.

Reference 7005A linjatason signaalit

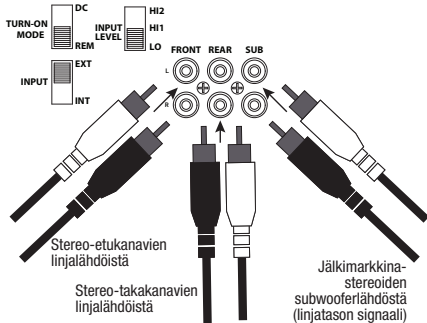

Reference 7005A kaiutintason tulosignaalit

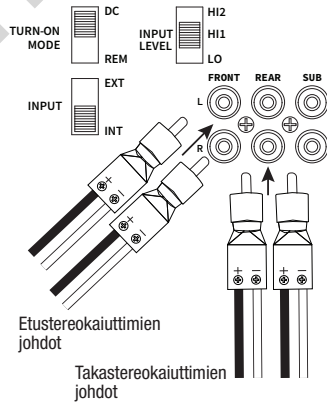

Huomaa: kun käytät linjatason signaaleja Reference 7005A:n kanssa, aseta "TURN-ON MODE"-kytkin "DC"-asettoon ja SUB "INPUT"-kytkin "INT"-asettoon ja "INPUT LEVEL"-kytkin "HI1"-asettoon. Jos ääntä ei kuulu, vaihda "INPUT LEVEL"-kytkin "HI2"-asettoon.

KAIUTTIMIEN JOHDOTUS

Reference 3004A 4-kanavainen lähtö (4 ohm / 2 ohm)

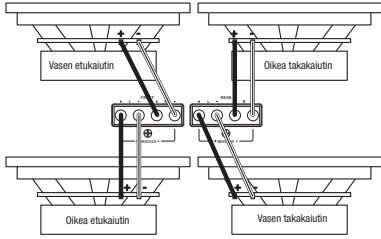

Reference 3004A 3-kanavainen lähtö (etu: 4 ohm / 2 ohm; taka: 4 ohm)

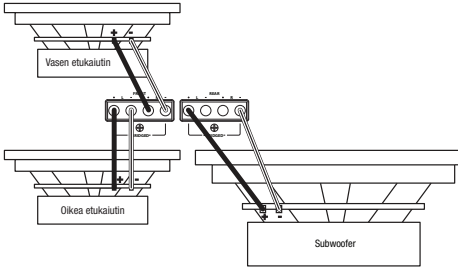

Reference 3004A 2-kanavainen lähtö (4 ohm)

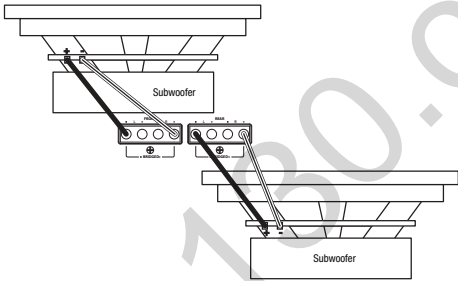

Reference 7005A 5-kanavainen lähtö (4 ohm / 2 ohm)

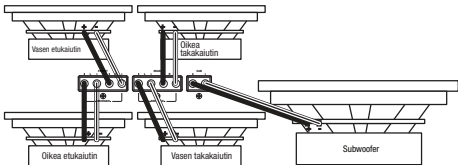

BASSON KAUKOSÄÄTIMEN KYTKEMINEN (VAIN REFERENCE 7005A)

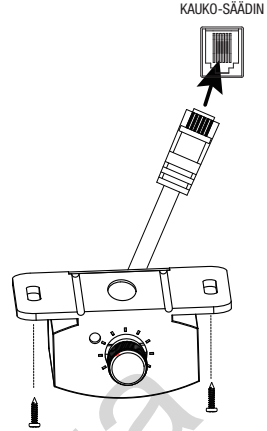

ASETUKSET VAHVISTUKSELLE (GAIN), JAKOSUOTIMILLE, VAIHEELLE JA BASSOTEHOSTUKSELLE

FI

Vahvistuksen asettaminen

1. Aloita **GAIN** säätö pienimmässä asennossa sekä jakotaajuuden ja bassotehostuksen säädöt puolivälissä.
2. Valitse etu- ja takakanaville tuttu musiikki. Valitse Reference 7005A:n subwooferkanavalle musiikki, jossa on merkittävä bassosisältö.
3. Käännä vastaanottimen äänenvoimakkuuden säädin ¼:aan sen kokonaislähdöstä.
4. Säädä **GAIN** -säädintä myötöpäivään kuunnellen tarkasti bassotoistoja. Jos kuulet äänen säröytymistä, käännä **GAIN** -säädintä vastapäivään vähentääksesi vahvistusta.



Jakosuotimen valinta

Etu- ja takakanavilla voit valita haluamasi jakosuotimen.

Valitse HPF, jotta vain tietyin pisteen yläpuolella olevat taajuudet pääsevät kaiuttimiin. Suositellaan, jos käytät subwooferia järjestelmässäsi, koska se rajaa matalimmat bassot full-range-kaiuttimilta.

Valitse LPF, jotta vain tietyin pisteen alapuolella olevat taajuudet pääsevät kaiuttimiin. Suositellaan, jos siltaatyt etu- tai takakanavat ohjatakseen subwoofer-kaiutinta.

Valitse FULL, jotta kaikki taajuudet tavoittavat kaiuttimet. Suositellaan, jos et käytä subwooferia järjestelmässäsi.

Huomaa: Reference 7005A:n subwooferkanava toimii vain alipäästötillassa.

Jakotaajuuden valinta

Valitse jakosuodatinkohta sopivaksi kuunteluasetuksille. Käännä osoittimia vasemmalle, kun haluat madallaa jakosuodinpistettä ja oikealle, kun haluat nostaa sitä. Koaksiaalikaiuttimien ja subwoofer-kaiuttimien jakosuodinpisteen optimaalinen asetus riippuu kuuntelumielityksestäsi.

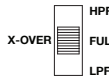

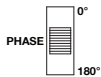

Valitse subwooferin vaihe
(vain Reference 7005A)

Vuorottele PHASE-kytkimen asentoa kokeillaksesi, mikä asento antaa puhtaimman bassotoiston.



Bassotehostuksen valitseminen
(vain Reference 7005A)

Säädä BASS-BOOST -säädintä myötöpäivään tai vastapäivään oman makusi mukaan.

TEKNISET TIEDOT

	Reference 3004A	Reference 7005A
Lähtöteho @ 4 ohm	75 W RMS x 4	50 W RMS x 4, 320 W x 1
Lähtöteho @ 2 ohm	100 W RMS x 4	75 W RMS x 4, 500 W x 1
Lähtöteho sillatussa tilassa	200 W RMS x 2 @ 4 ohm	150 W RMS x 2 @ 4 ohm
Taajuusvaste	10 Hz - 40 kHz	10 Hz - 40 kHz / 10-320 Hz
Jakotaajuudet	32-320 Hz säädettävä, 12 dB / oktaavi	32-320 Hz säädettävä yli- ja alipäästö (edessä ja takana); 32-320 Hz alipäästö (subwoofer); 12 dB / oktaavi
Linjatson tulon herkkyys	200 mV rms – 2,0 V rms	200 mV rms – 2,0 V rms
Kaiutintason tulon herkkyys	2,0 mV rms – 20 V rms	2,0 mV rms – 20 V rms
Signaali-kohinasuhde	> 80 dB	>80 dB
THD+ N @ nimellisteho	< 1 %	< 1 %
Sulake	30 x 2	30 x 3
Käyttöjännite	9–16 V	9–16 V
Mitat (L x K x S)	320 mm x 55,5 mm x 180 mm (12-5/8" x 2-3/16" x 7-1/8")	360 mm x 56 mm x 180 mm (14-3/16" x 2-3/16" x 7-1/8")
Paino	3.15 kg	4.02 kg
Suosittelut kaapeliuokitus (Gauge)	8	4

VIANMÄÄRITYS

Ei ääntä. VIRRRAN MERKKIVALO on pois päältä.

- BATT+ ja/tai REM -liittimissä ei ole jännitettä tai maadoitus on huono. Tarkista vahvistimen liittimien jännitteet volttimittarilla.

Ei ääntä. SUOJAUKSEN MERKKIVALO vilkkuu 4 sekunnin välein.

- Vahvistimen lähdössä tasavirtajännite. Vahvistin saattaa vaatia huoltoa. Katso huoltotiedot mukana toimitetusta takuukortista.

Ei ääntä. SUOJAUKSEN ja VIRRRAN MERKKIVALOT välkkyvät.

- BATT+ -liittännän jännite on alle 9 voltia. Tarkasta ajoneuvon latausjärjestelmä.

Ei ääntä. SUOJAUKSEN MERKKIVALO on päällä.

- Vahvistin on ylikuumentunut. Varmista, ettei vahvistimen jäähtytys ole estynyt sen asennuspaikassa. Synny voi olla myös ylijännite (yli 16 V) tai alijännite (alle 8,5 V) BATT+ -liittännässä. Tarkasta ajoneuvon latausjärjestelmä.

Vahvistimen sulake palaa toistuvasti.

- Johdotus on kytketty väärin tai järjestelmässä on oikosulku. Tarkista johdotuksen liitännät.

Ääni säröytyy.

- Vahvistusta ei ole asetettu oikein. Tarkista asetukset. Tarkista kaiutinkaapelit oikosulkujen ja maalenkkien varalta. Vahvistin tai lähdeyksikkö voi olla viallinen.

Ei ääntä. SUOJAUKSEN MERKKIVALO vilkkuu.

- Kaiutin tai johto oikosulussa. Irrota kaiutinjohdot yksi kerrallaan oikosulussa olevan johdon tai kaiuttimen paikantamiseksi ja korjaa oikosulku.

Musiikissa ei ole dynamiikkaa tai "potkua".

- Kaiuttimet kytketty väärin. Tarkasta kaiutin kytkentöjen napaisuudet.

Moottorin ääntä (vinkunaa tai napsahduksia) järjestelmässä moottorin ollessa päällä.

- Vahvistin poimii laturin aiheuttamia häiriöitä. Tarkista ensin vahvistimen maadoitusliitännät. Irrallaan oleva tai väärin kytketty maajohto on yksi häiriöiden pääaiheuttajista. Vähennä vahvistusta. Siirrä RCA-äänijohdot kauemmaksi virtajohdoista. Voi myös olla välttämätöntä asentaa laturin häiriönpoistosuodatin virtajohtoon akun ja laturin välille.



HARMAN International Industries,
Incorporated 8500 Balboa Boulevard,
Northridge, CA 91329 USA
www.infinityspeakers.com

© 2019 HARMAN International Industries, Incorporated. Kaikki oikeudet pidätetään. Infinity on HARMAN International Industries, Incorporated -yrityksen tavaramerkki, joka on rekisteröity Yhdysvalloissa ja/tai muissa maissa. Toimintoja, teknisiä ominaisuuksia ja ulkomuotoa voidaan muuttaa ilman erillistä ilmoitusta.

CONTENU DE LA BOÎTE

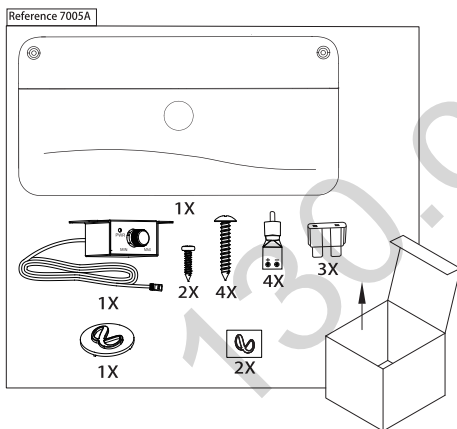
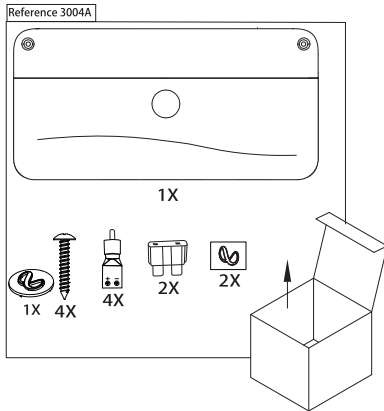

ACCÈS AUX CONNECTEURS / AU PANNEAU DE COMMANDE

1. Faites glisser le couvercle vers le bas.

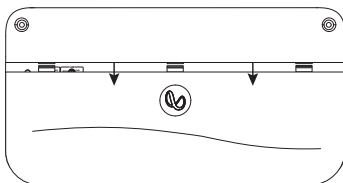

2. Retirez le couvercle.

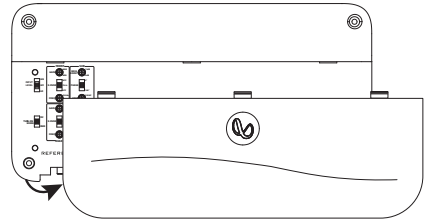

MONTAGE DE L'AMPLIFICATEUR

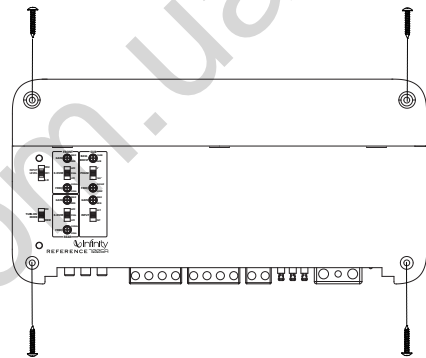

FR

Remarque : il est recommandé de faire toutes les connexions des câbles avant de monter l'amplificateur.

IMPORTANT : débranchez la borne négative de la batterie (-) du véhicule avant de commencer l'installation.

- Portez toujours des lunettes de protection pour utiliser des outils.
- Choisissez un emplacement de montage sûr, sans humidité. Vérifiez les espaces des deux côtés de la surface de montage prévue. Veillez à ce que des vis ou des fils ne percent pas de canalisations de freins, de carburant ou des faisceaux de câblage, et que le cheminement des fils ne nuira pas à la sécurité de fonctionnement du véhicule. Soyez prudent lors des perçages ou des découpes dans la zone de montage.
- Choisissez un emplacement permettant une circulation d'air suffisante.
- Ne montez pas l'amplificateur avec son radiateur dessous, car ceci nuit à son refroidissement.
- Montez l'amplificateur de sorte qu'il ne soit pas endommagé par les pieds des passagers arrière ou le déplacement du chargement dans le coffre.

CÂBLAGE DE L'ALIMENTATION ET DE LA MASSE

Sur l'amplificateur :

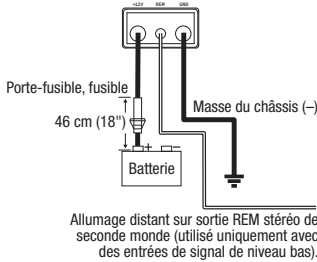

Au point de masse :

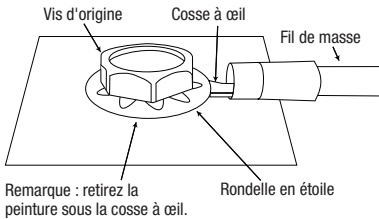

Remarque : lors de l'utilisation de signaux de niveau bas et du fil d'allumage télécommandé avec le Reference 7005A, réglez le commutateur « TURN-ON MODE » sur « REM », le commutateur SUB « INPUT » sur « EXT », et le commutateur « INPUT LEVEL » sur « LO ».

Signaux de niveau high du Reference 3004A

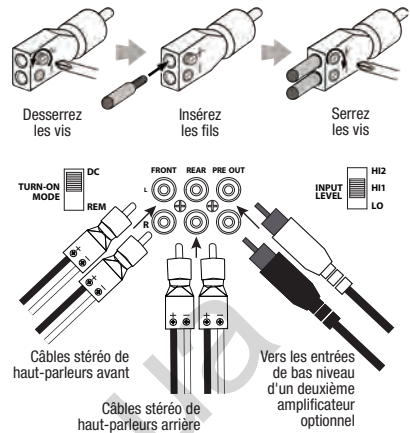

Remarque : si vous utilisez des signaux de niveau élevé et un fil d'allumage télécommandé, réglez le commutateur « TURN-ON MODE » sur « DC » et le commutateur « INPUT LEVEL » sur « HI1 ». En l'absence de son, basculez le commutateur « INPUT LEVEL » sur « HI2 ».

Signaux de niveau élevé du Reference 7005A

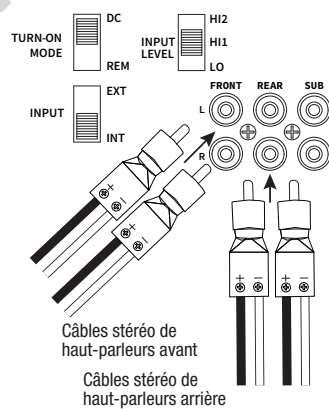

Remarque : lors de l'utilisation de signaux de niveau élevé avec le Reference 7005A, réglez le commutateur « TURN-ON MODE » sur « DC », le commutateur SUB « INPUT » sur « INT », et le commutateur « INPUT LEVEL » sur « HI1 ». En l'absence de son, basculez le commutateur « INPUT LEVEL » sur « HI2 ».

CÂBLAGE DU SIGNAL D'ENTRÉE

Signaux de niveau bas du Reference 3004A

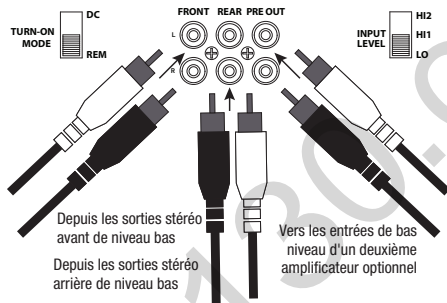

Remarque : si vous utilisez des signaux de niveau bas et un fil d'allumage télécommandé, réglez le commutateur « TURN-ON MODE » sur « REM » et le commutateur « INPUT LEVEL » sur « LO ».

Signaux de niveau bas du Reference 7005A

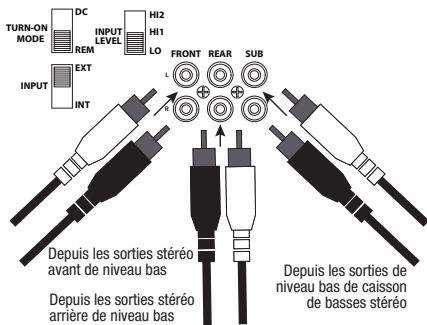

CÂBLAGE DE LA SORTIE

Sortie à 4 canaux du Reference 3004A (4 ohms / 2 ohms)

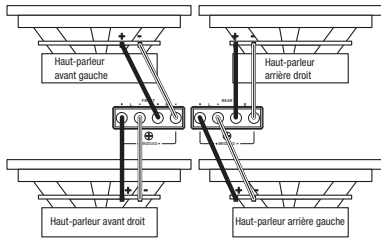

Sortie à 3 canaux du Reference 3004A (avant : 4 ohms / 2 ohms, arrière : 4 ohms)

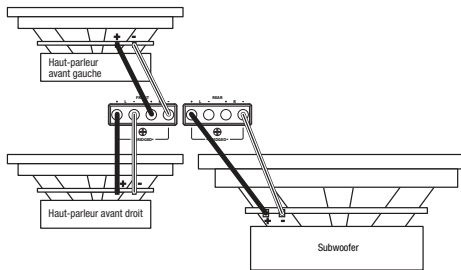

Sortie à 2 canaux du Reference 3004A (4 ohms)

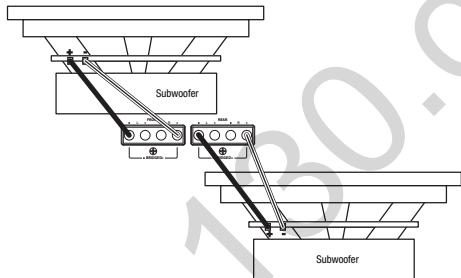

Sortie à 5 canaux du Reference 7005A (4 ohms / 2 ohms)

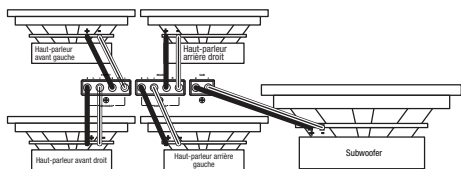

BRANCHEMENT DE LA TÉLÉCOMMANDE DES GRAVES (REFERENCE 7005A UNIQUEMENT)

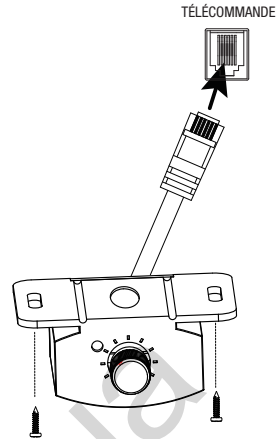

RÉGLAGE DU GAIN, DU FILTRE DE RÉPARTITION ET DE L'AMPLIFICATION DES GRAVES

FR

Réglage du gain

1. Démarrez avec la commande **GAIN** réglée au minimum et la commandes de répartition tournée à mi-course.
2. Pour les canaux avant et arrière, choisissez une musique que vous connaissez bien. Pour le canal de caisson de basses du Reference 7005A, choisissez une musique riche en graves.
3. Réglez le volume de votre récepteur à ¾ de sa puissance totale.
4. Réglez la commande **GAIN** dans le sens horaire, en écoutant attentivement la sortie des graves. Si vous percevez une distorsion, tournez la commande **GAIN** dans le sens trigonométrique pour diminuer le gain.



Sélection du mode de croisement

Sur les canaux avant et arrière, vous pouvez sélectionner votre mode de croisement préféré.

Choisissez HPF pour n'autoriser que les fréquences supérieures à un certain point vers vos haut-parleurs. Option recommandée si vous utilisez un caisson de basses dans votre système, car il filtre les basses fréquences de vos haut-parleurs large bande.

Choisissez LPF pour n'autoriser que les fréquences inférieures à un certain point vers vos haut-parleurs. Option recommandée si vous pontez les canaux avant ou arrière pour alimenter un caisson de basses.

Choisissez FULL pour autoriser toutes les fréquences vers vos haut-parleurs. Option recommandée si vous n'utilisez pas de caisson de basses dans votre système.

Remarque : le mode de croisement du canal de caisson de basses du Reference 7005A est uniquement passe-bas.





Sélection de la fréquence de croisement

Choisissez le point de croisement en fonction de vos préférences d'écoute. Tournez les réglages vers la gauche pour abaisser le point de croisement et vers la droite pour l'élever. Les réglages de croisement exacts des haut-parleurs coaxiaux et des caissons de basses dépendent de vos préférences d'écoute.

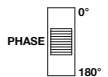

Sélection de la phase du caisson de basses (Référence 7005A uniquement)

Basculez le commutateur PHASE dans les deux sens pour déterminer quel réglage produit la sortie de graves la plus propre.



Sélection de l'amplification des graves (Référence 7005A uniquement)

Réglez la commande BASS-BOOST dans les sens horaire ou trigonométrique en fonction de votre goût.

SPÉCIFICATIONS

	Reference 3004A	Reference 7005A
Puissance de sortie sous 4 ohms	4 x 75 watts RMS	4 x 50 watts RMS + 1 x 320 watts RMS
Puissance de sortie sous 2 ohms	4 x 100 watts RMS	4 x 75 watts RMS + 1 x 500 watts RMS
Puissance de sortie en mode ponté	2 x 200 Watts RMS sous 4 ohms	2 x 150 Watts RMS sous 4 ohms
Réponse en fréquence	10 - 40 kHz	10 - 40 kHz / 10 - 320 Hz
Fréquences de croisement :	32 - 320 Hz variable, 12 dB/octave	Passes-haut et passe-bas variable 32-320 Hz (avant et arrière), passe-bas 32-320 Hz (caisson de basses), 12 dB/octave
Sensibilité d'entrée de niveau ligne	200 mV rms – 2,0 V rms	200 mV rms – 2,0 V rms
Sensibilité d'entrée de niveau élevé	2,0 V rms – 20 V rms	2,0 V rms – 20 V rms
Rapport signal sur bruit	> 80 dB	> 80 dB
DHT+ B à la puissance nominale	< 1 %	< 1 %
Valeur du fusible :	30 x 2	30 x 3
Tension de service	9~16 V	9~16 V
Dimensions (L x H x P)	320 mm x 55,5 mm x 180 mm (12-5/8" x 2-3/16" x 7-1/8")	360 mm x 56 mm x 180 mm (14-3/16" x 2-3/16" x 7-1/8")
Poids	3.15 kg	4.02 kg
Calibres de fils recommandés	8	4

RÉSOLUTION DES PROBLÈMES

Aucun son et TÉMOIN D'ALIMENTATION éteint.

- Aucune tension sur BATT + et/ou aux bornes REM, ou connexion de masse mauvaise ou absente. Vérifiez les tensions aux bornes de l'amplificateur avec un voltmètre.

Aucun son et clignotement du TÉMOIN DE PROTECTION toutes les 4 secondes.

- Tension CC sur la sortie de l'amplificateur. L'amplificateur peut devoir être révisé, consultez la carte de garantie jointe pour des informations sur le service.

Aucun son et clignotement des TÉMOINS D'ALIMENTATION ET DE PROTECTION.

- Tension inférieure à 9 V sur la connexion à BATT +. Contrôlez le circuit de charge du véhicule.

Aucun son et TÉMOIN DE PROTECTION allumé.

- L'amplificateur a surchauffé. Vérifiez que le refroidissement de l'amplificateur n'est pas empêché à l'emplacement de montage. Ou une tension supérieure à 16 V (ou inférieure à 8,5 V) est présente sur la connexion à BATT +. Contrôlez le circuit de charge du véhicule.

Le fusible d'amplificateur fond constamment.

- Le câblage est erroné ou il y a un court-circuit. Vérifiez les connexions du câblage.

Son déformé.

- Le gain n'est pas réglé correctement. Vérifiez le réglage. Recherchez des court-circuits ou des masses sur les câbles. L'amplificateur ou l'appareil source peuvent être défectueux.

Son déformé et TÉMOIN DE PROTECTION clignotant.

- Court-circuit dans le haut-parleur ou le fil. Débranchez un fil de haut-parleur à la fois pour localiser le haut-parleur ou le fil en court-circuit puis réparez.

La musique manque de dynamique ou de « punch ».

- Les haut-parleurs ne sont pas connectés correctement. Vérifiez la bonne polarité des connexions des haut-parleurs.

Bruit de moteur - couinement ou cliquetis - dans le système lorsque le moteur tourne.

- L'amplificateur capte le bruit de l'alternateur. Vérifiez d'abord les connexions de masse de l'amplificateur – une masse lâche ou insuffisante est l'une des principales causes de bruit. Réduisez le gain. Éloignez les câbles audio RCA des fils d'alimentation. Le montage d'un filtre de bruit d'alternateur sur la ligne d'alimentation entre la batterie et l'alternateur peut également être nécessaire.

FR



HARMAN International Industries, Incorporated 8500 Balboa Boulevard, Northridge, CA 91329 USA
www.infinityspeakers.com

© 2019 HARMAN International Industries, Incorporated. Tous droits réservés. Infinity est une marque commerciale de HARMAN International Industries, Incorporated, déposée aux États-Unis et/ou dans d'autres pays. Les caractéristiques, les spécifications et l'aspect sont susceptibles d'être modifiés sans préavis.

CONTENUTO DELLA CONFEZIONE

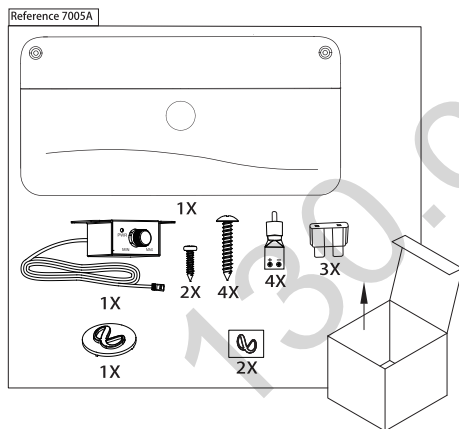
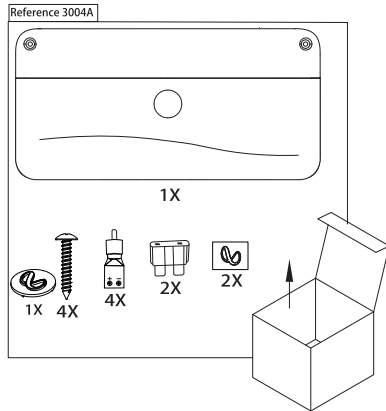

ACCESSO AI CONNETTORI/ PANNELLO DI CONTROLLO

1. Far scorrere verso il basso la copertura del pannello

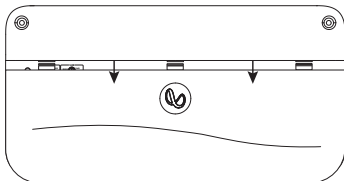

2. Rimuovere la copertura del pannello

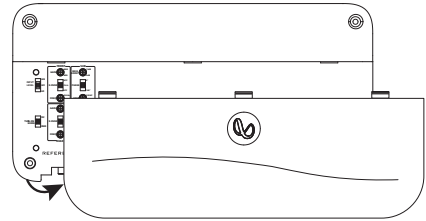

MONTAGGIO DELL'AMPLIFICATORE

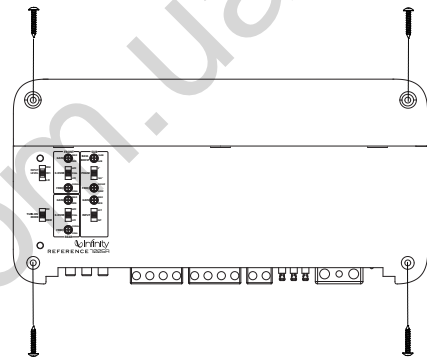

Nota: Si raccomanda di effettuare tutti i collegamenti dei cavi prima di montare l'amplificatore.

IMPORTANTE: Prima di iniziare l'installazione, scollegare il terminale negativo (-) della batteria del veicolo.

- Quando si usano gli attrezzi, indossare sempre gli occhiali di protezione.
- Scegliere una posizione di montaggio sicura, lontano dall'umidità. Controllare che vi sia spazio libero su entrambi i lati della superficie di montaggio prevista. Accertarsi che le viti o i cavi non forino le linee dei freni, le linee del carburante o i cablaggi e che l'instradamento dei cavi non interferisca con il funzionamento in sicurezza del veicolo. Prestare attenzione quando si effettuano delle perforazioni o tagli nella zona di montaggio.
- Scegliere una posizione che fornisca una sufficiente circolazione dell'aria.
- Non montare l'amplificatore con il dissipatore di calore rivolto verso il basso, poiché ciò interferisce con il raffreddamento.
- Montare l'amplificatore in modo tale che non sia danneggiato da parte dei piedi dei passeggeri dei sedili posteriori o dal carico del bagagliaio che si sposta.

CABLAGGIO PER L'ALIMENTAZIONE E LA MESSA A TERRA

Verso l'amplificatore:

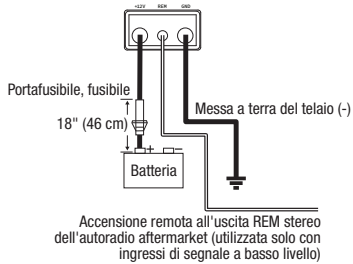

Nel punto di messa a terra:

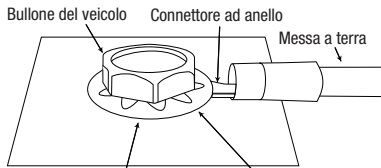

Nota: Rimuovere ogni traccia di vernice sotto il connettore ad anello

Nota: quando si utilizzano segnali di basso livello ed il cavo di accensione a distanza con il Reference 7005A, posizionare l'interruttore "TURN-ON MODE" su "REM" e l'interruttore del SUB "INPUT" su "EXT" e l'interruttore "INPUT LEVEL" su "LO".

Segnali ad alto livello Reference 3004A

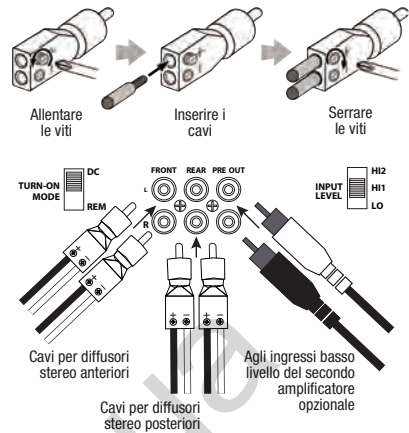

Nota: quando si utilizzano segnali ad alto livello, posizionare l'interruttore "TURN-ON MODE" su "DC" e l'interruttore "INPUT LEVEL" su "HI1". Se non viene riprodotto alcun suono, cambiare l'interruttore "INPUT LEVEL" su "HI2".

CABLAGGIO PER IL SEGNALE AUDIO

Segnali a basso livello Reference 3004A

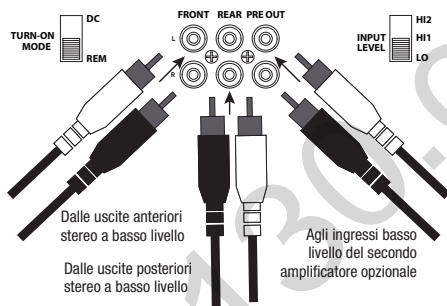

Nota: quando si utilizzano segnali di basso livello ed il cavo di accensione a distanza, posizionare l'interruttore "TURN-ON MODE" su "REM" e l'interruttore "INPUT LEVEL" su "LO".

Segnali a basso livello Reference 7005A

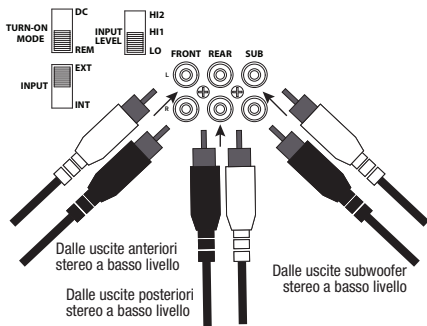

Segnali ad alto livello Reference 7005A

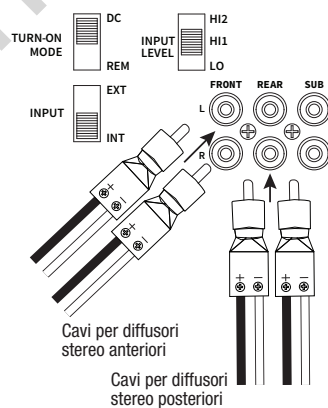

Nota: quando si utilizzano segnali ad alto livello con il Reference 7005A, posizionare l'interruttore "TURN-ON MODE" su "DC", l'interruttore del SUB "INPUT" su "INT", e l'interruttore "INPUT LEVEL" su "HI1". Se non viene riprodotto alcun suono, cambiare l'interruttore "INPUT LEVEL" su "HI2".

CABLAGGIO PER L'USCITA AUDIO

Uscita a 4 canali del Reference 3004A (4 ohm/2 ohm)

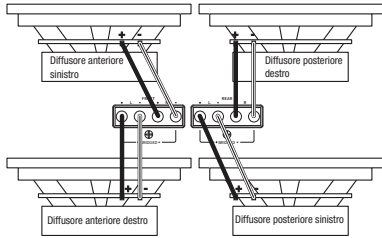

Uscita a 3 canali del Reference 3004A (Anteriore: 4 ohm/2 ohm; Posteriore: 4 ohm)

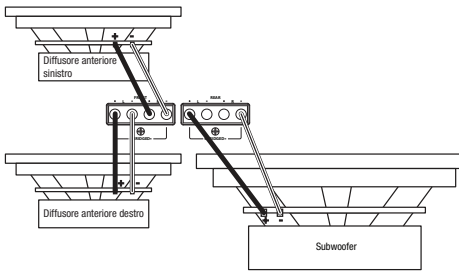

Uscita a 2 canali del Reference 3004A (4 ohm)

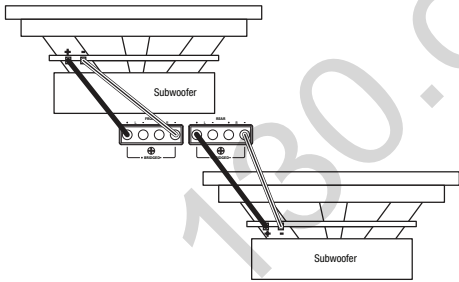

Uscita a 5 canali del Reference 7005A (4 ohm/2 ohm)

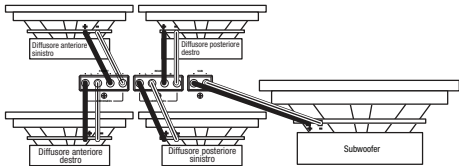

COLLEGAMENTO DEL CONTROLLER REMOTO DEI BASSI (SOLO REFERENCE 7005A)

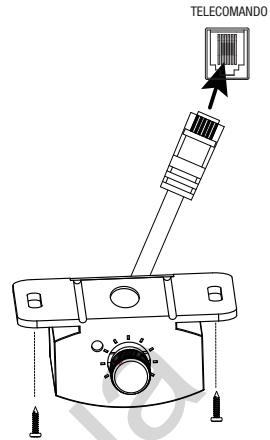

IMPOSTAZIONE DEL GUADAGNO, CROSSOVER E BASS BOOST

Impostazione del guadagno (Gain)

1. Cominciare con il controllo **GAIN** impostato al minimo, e con il controllo del crossover ruotato a metà.
2. Per i canali anteriore e posteriore, scegliere un brano musicale familiare. Per il canale subwoofer del Reference 7005A, scegliere un brano musicale con molti bassi.
3. Impostare il controllo del volume dell'autoradio a $\frac{3}{4}$ del livello massimo.
4. Regolare il controllo **GAIN** in senso orario, ascoltando attentamente la riproduzione dei bassi. Se il suono è distorto, ruotare il controllo **GAIN** in senso antiorario per ridurre il guadagno.

Scelta della modalità di crossover

Sui canali anteriore e posteriore, è possibile selezionare la modalità crossover preferita.

Scegliere HPF per consentire solo alle frequenze al di sopra di un certo punto di raggiungere i diffusori. Impostazione consigliata se nel sistema si utilizza un subwoofer, in quanto vengono inviati pochi bassi ai diffusori full-range.

Scegliere LPF per consentire solo alle frequenze al di sotto di un certo punto di raggiungere i diffusori. Raccomandato se si sta ponticellando i canali anteriori o posteriori per pilotare un subwoofer.

Scegliere FULL per consentire a tutte le frequenze di raggiungere i diffusori. Consigliato se non si utilizza un subwoofer nel sistema.

Nota: La modalità crossover per il canale subwoofer del Reference 7005A è solo passa-basso.

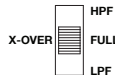

IT



Scelta della frequenza di crossover

Scegliere il punto di crossover in base alle preferenze di ascolto. Girare le ghiera verso sinistra per abbassare il punto di frequenza del crossover e verso destra per alzare il punto di frequenza. L'impostazione perfetta del crossover per gli speaker coassiali ed i subwoofer, in ultima istanza è comunque legata ai gusti personali dell'ascoltatore.

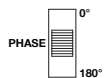

Selezione della fase del subwoofer (solo Reference 7005A)

Spostare il controllo PHASE in avanti e indietro per determinare quale impostazione fornisce una migliore riproduzione delle basse frequenze.



Selezione del bass boost (solo Reference 7005A)

Regolare il comando BASS-BOOST in senso orario od antiorario a seconda dei propri gusti.

SPECIFICHE

	Reference 3004A	Reference 7005A
Potenza nominale in uscita @ 4 ohm	75 watt RMS x 4	50 watt RMS x 4 + 320 watt RMS x 1
Potenza nominale in uscita @ 2 ohm	100 watt RMS x 4	75 watt RMS x 4 + 500 watt RMS x 1
Potenza in uscita in modalità a ponte:	200 watt RMS x 2 a 4 ohm	150 watt RMS x 2 a 4 ohm
Risposta in frequenza	10-40 K Hz	10-40 K Hz / 10-320 Hz
Frequenze di Crossover	32-320 Hz variabile, 12 dB/ottava	32-320 Hz variabile passa alto e passa basso (anteriore e posteriore); 32-320 Hz passa basso (subwoofer); 12 dB/ottava
Sensibilità ingresso Line-level	200 mVrms - 2,0 Vrms	200 mVrms - 2,0 Vrms
Sensibilità ingresso High-level	2,0 Vrms - 20 Vrms	2,0 Vrms - 20 Vrms
Rapporto segnale-rumore	>80 dB	>80 dB
THD+N @ potenza nominale	<1%	<1%
Fusibile	30 x 2	30 x 3
Tensione di funzionamento	9-16 V	9-16 V
Dimensioni (L x A x P)	12-5/8" x 2-3/16" x 7-1/8" (320 mm x 55,5 mm x 180 mm)	14-3/16" x 2-3/16" x 7-1/8" (360 mm x 56 mm x 180 mm)
Peso	3.15 kg	4.02 kg
Sezione raccomandata dei cavi	8	4

RISOLUZIONE DEI PROBLEMI

Assenza di suono e la SPIA di ALIMENTAZIONE è spenta.

- Nessuna tensione ai terminali BATT+ e/o REM, o cattivo o nessun collegamento a terra. Controllare la tensione ai terminali dell'amplificatore con un VOM.

Assenza di suono e la SPIA di PROTEZIONE lampeggia ogni 4 secondi.

- Tensione continua (DC) in uscita dall'amplificatore. L'amplificatore potrebbe avere bisogno di assistenza; fare riferimento alla scheda di garanzia allegata per informazioni sul servizio di assistenza.

Assenza di suono e le SPIE di PROTEZIONE e ALIMENTAZIONE sono accese.

- Tensione inferiore a 9 V sul terminale BATT+. Controllare il sistema di ricarica del veicolo.

Assenza di suono e la SPIA di PROTEZIONE è accesa.

- L'amplificatore è surriscaldato. Assicurarsi che il raffreddamento dell'amplificatore non sia ostacolato nella posizione di montaggio. Oppure, potrebbe essere presente una tensione superiore a 16 V (o inferiore a 8,5 V) sul morsetto BATT+. Controllare il sistema di ricarica del veicolo.

Un fusibile dell'amplificatore si è bruciato.

- Il cablaggio è collegato in modo non corretto o è presente un corto circuito. Controllare i collegamenti dei cavi.

Suono distorto.

- Il guadagno non è regolato correttamente. Controllare l'impostazione. Controllare la presenza di corto circuiti sui cavi. L'amplificatore o la sorgente potrebbero essere difettosi.

Suono distorto e la SPIA di PROTEZIONE lampeggia.

- Corto circuito su un diffusore o su un cavo. Rimuovere i terminali degli altoparlanti uno alla volta per individuare il diffusore o il cavo in corto, e ripararlo.

La riproduzione musicale manca di dinamica o di "punch".

- Gli speaker non sono collegati correttamente. Controllare la corretta polarità dei collegamenti degli altoparlanti.

Rumore del motore - continuo o intermittente - nel sistema quando il motore è acceso.

- L'amplificatore è disturbato dall'alternatore. Innanzitutto, controllare i collegamenti a terra dell'amplificatore - una messa a terra poco serrata o impropria è una delle principali cause di rumori estranei. Abbassare il guadagno. Spostare i cavi audio RCA lontano dai cavi di alimentazione. Potrebbe inoltre essere necessario installare un filtro antirumore per l'alternatore sulla linea elettrica tra la batteria e l'alternatore.



HARMAN International Industries, Incorporated
8500 Balboa Boulevard,
Northridge, CA 91329 USA
www.infinityspeakers.com

© 2019 HARMAN International Industries, Incorporated. Tutti i diritti riservati. Infinity è un marchio di HARMAN International Industries, Incorporated, registrato negli Stati Uniti e/o in altri Paesi. Le funzionalità, le specifiche e l'aspetto sono passibili di modifiche senza preavviso.

VERPAKKINGSINHOUD

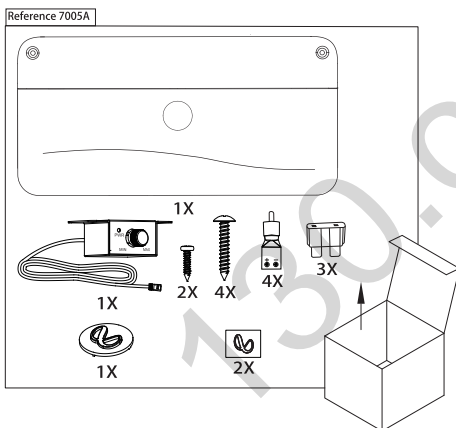
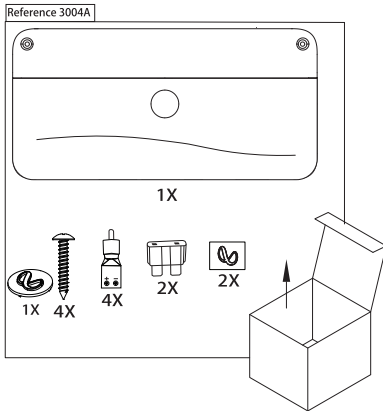

GEbruik VAN CONNECTOREN/ BEDIENINGSPANEEL

1. Schuif het kapje naar beneden

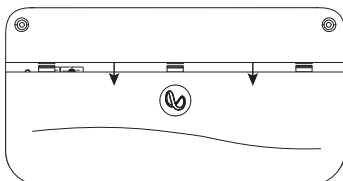

2. Verwijder het kapje

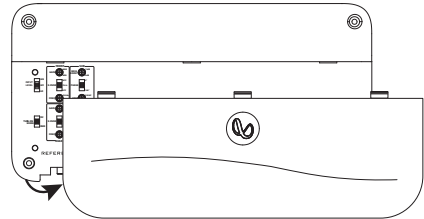

DE VERSTERKER MONTEREN

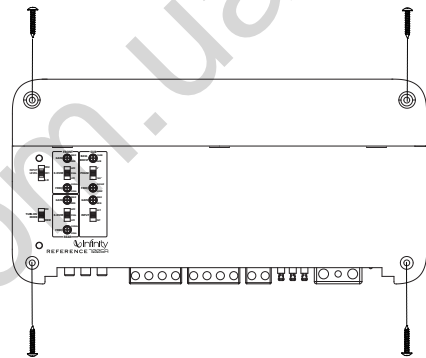

Opmerking: Het wordt aanbevolen dat je alle draadverbindingen maakt voordat je de versterker permanent monteert.

BELANGRIJK: De min-kabel (-) van de autoaccu loskoppelen voordat u tot installatie overgaat.

- Draag bij gebruik van gereedschappen altijd een veiligheidsbril.
- Kies een veilige montagelocatie die niet aan vocht wordt blootgesteld. Controleer de ruimte aan beide zijden van de montageplaats. Zorg ervoor dat de schroeven of kabels geen remleidingen, brandstofleidingen of kabelbundels kunnen beschadigen, en dat de bekabeling de veilige werking van het voertuig niet kan belemmeren. Wees voorzichtig bij het boren of zagen in de montageplek.
- Kies een locatie die voldoende luchtcirculatie biedt.
- Monteer de versterker niet met de heatsink (koellichaam) naar beneden gericht, omdat dit de koeling van de versterker belemmert.
- Monteer de versterker zodanig dat deze niet door de voeten van achterpassagiers of schuivende lading in de kofferbak kan worden beschadigd.

BEDRADING VOOR STROOM EN AARDE

Bij versterker:

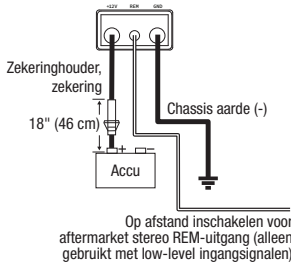

Op aardingslocatie:

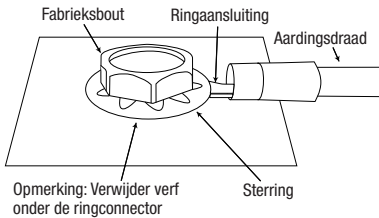

BEDRADING VOOR INGANGSSIGNAAL

Reference 3004A low-level signals

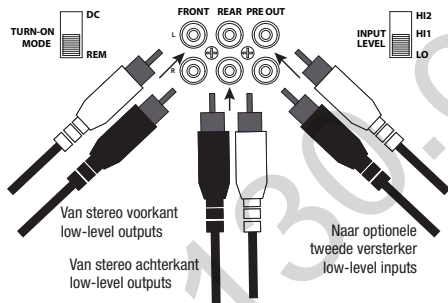

Opmerking: bij gebruik van low-level signalen en externe inschakelkabel, zet je de "TURN-ON MODE" schakelaar op "REM" en de "INPUT LEVEL" schakelaar op "LO".

Reference 7005A low-level signalen

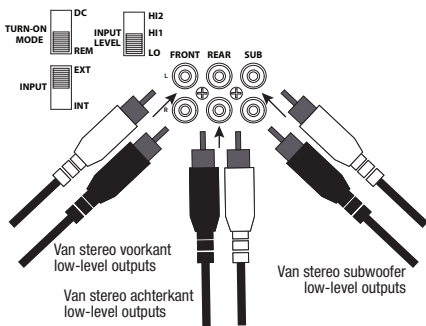

Opmerking: bij gebruik van low-level signalen en externe inschakelkabel met de Reference 7005A, zet je de "TURN-ON MODE" schakelaar op "REM" en de SUB "INPUT" schakelaar op "EXT" and de "INPUT LEVEL" schakelaar op "LO".

Reference 3004A high-level signalen

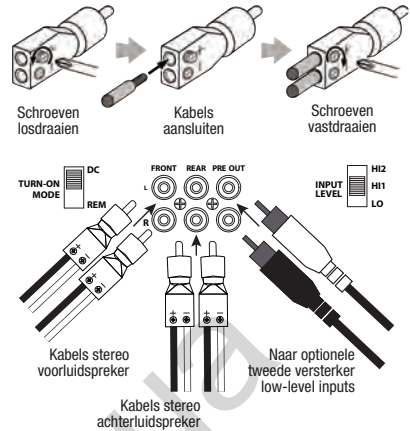

Opmerking: bij gebruik van high-level signalen, zet je de "TURN-ON MODE" schakelaar op "DC" en de "INPUT LEVEL" schakelaar op "HI1". Als er geen geluid wordt afgespeeld, zet je de "INPUT LEVEL" schakelaar op "HI2".

Reference 7005A high-level input signalen

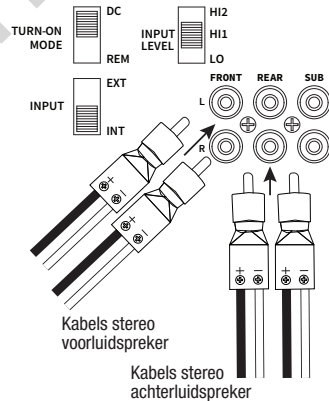

Opmerking: Stel bij gebruik van high-level signalen met de Reference 7005A zet je de "TURN-ON MODE" schakelaar op "DC", de SUB "INPUT" schakelaar op "INT", en de "INPUT LEVEL" schakelaar op "HI1". Als er geen geluid wordt afgespeeld, zet je de "INPUT LEVEL" schakelaar op "HI2".

BEDRADING VOOR UITVOER

Reference 3004A 4-kanaals uitgang (4 ohm/2 ohm)

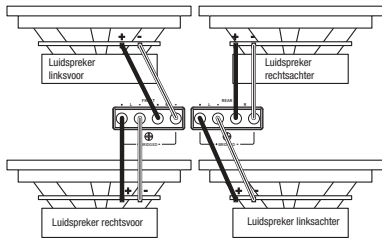

Reference 3004A 3-kanaals uitgang (Voor: 4 ohm/2 ohm; Achter: 4 ohm)

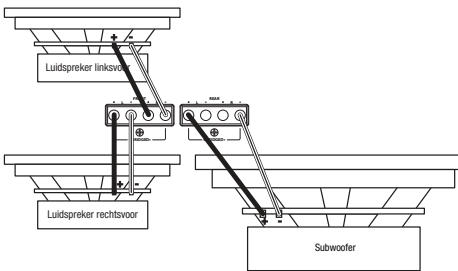

Reference 3004A 2-kanaals uitgang (4 ohm)

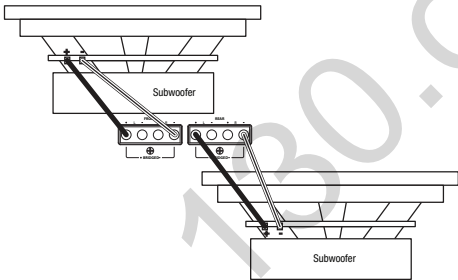

Reference 7005A 5-kanaals uitgang (4 ohm/2 ohm)

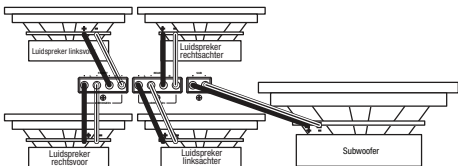

DE EXTERNE BASCONTROLLER AANSLUITEN (ALLEEN REFERENCE 7005A)

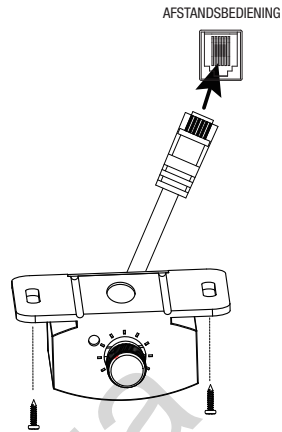

VERSTERKING (GAIN), CROSSOVERS EN BASVERSTERKING INSTELLEN

Versterking (gain) instellen

1. Zet eerst de **GAIN** regelaar op minimum, en de crossover-regeling halverwege.
2. Kies voor de voor- en achterkanalen muziek waarmee je goed bekend bent. Kies voor het subwooferkanaal op de Reference 7005A muziek met sterke bas.
3. Zet de volumeregelaar op de ontvanger op $\frac{3}{4}$ van het totale vermogen.
4. Draai de **GAIN** regelaar naar rechts en luister naar de basweergave. Als je vervorming hoort, draai je de **GAIN** regelaar naar links om de versterking (gain) te verminderen.

Crossover-modus selecteren

Op de voor- en achterkanalen kun je de gewenste crossover-modus selecteren.

Selecteer HPF om alleen frequenties boven een bepaald punt je luidsprekers te laten bereiken. Deze stand is aanbevolen wanneer je een subwoofer in je systeem gebruikt.

Selecteer LPF zodat alleen frequenties onder een bepaald punt je luidsprekers kunnen bereiken. Aanbevolen als je de voor- of achterkanalen koppelt om een subwoofer van stroom te voorzien.

Selecteer FULL zodat alle frequenties je luidsprekers kunnen bereiken. Aanbevolen als je geen subwoofer in je systeem gebruikt.

Opmerking: De crossover-modus voor het subwooferkanaal van de Reference 7005A is alleen low-pass.

Crossover-frequentie selecteren

Kies het crossover-punt dat past bij de luistervoorkeuren. Draai de knoppen naar links om het crossover-punt te verlagen en naar rechts om het crossover-punt te verhogen. Exacte crossover-instellingen voor coaxiale luidsprekers en subwoofers zijn afhankelijk van je luistervoorkeuren.



NL

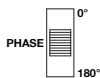

De fase van de subwoofer selecteren (Alleen Reference 7005A)

Schakel de **PHASE** heen en weer om te bepalen welke instelling de meest zuivere basweergave biedt.



De basversterking selecteren (Alleen Reference 7005A)

Draai de **BASS-BOOST** naar links of rechts op basis van je eigen voorkeur.

SPECIFICATIES

	Reference 3004A	Reference 7005A
Uitgangsvermogen @ 4 ohm	75 watt RMS x 4	50 watt RMS x 4, 320 watt x 1
Uitgangsvermogen @ 2 ohm	100 watt RMS x 4	75 watt RMS x 4, 500 watt x 1
Uitgangsvermogen in bridge modus	200 watt RMS x 2 bij 4 ohm	150 watt RMS x 2 bij 4 ohm
Frequentiebereik	10-40 K Hz	10-40 K Hz / 10-320 Hz
Crossover-frequenties	32-320 Hz variabel, 12 dB/ octaaf	32-320 Hz variabele high- en low-pass (voor en achter); 32-320 Hz low-pass (subwoofer); 12 dB/ octaaf
Lijn-niveau ingangsgoedigheid	200 mVrms - 2,0 Vrms	200 mVrms - 2,0 Vrms
High-level input gevoeligheid	2,0 Vrms - 20 Vrms	2,0 Vrms - 20 Vrms
Signaal-ruisverhouding	>80 dB	>80 dB
THD+N @ nominaal vermogen	<1%	<1%
Zekering	30 x 2	30 x 3
Werkspanning	9-16 V	9-16 V
Afmetingen (B x H x D)	12-5/8" x 2-3/16" x 7-1/8" (320 mm x 55,5 mm x 180 mm)	14-3/16" x 2-3/16" x 7-1/8" (360 mm x 56 mm x 180 mm)
Gewicht	3.15 kg	4.02 kg
Aanbevolen draaddikte	8	4

VERHELPEN VAN STORINGEN

Geen geluid en AAN-/UITINDICATOR is uit.

- Geen spanning op aansluitklemmen BATT+ en/of REM of een slechte of geen aardaansluiting. Controleer de spanningen op de aansluitingen van de versterker met VOM.

Geen geluid en de BEVEILIGINGSINDICATOR knippert iedere 4 seconden.

- Gelijkspanning op uitgang van de versterker. Versterker heeft mogelijk onderhoud nodig; zie bijgevoegde garantiekaart voor service-informatie.

Geen geluid en de BEVEILIGING en AAN-/UIT INDICATORS knipperen.

- Spanning minder dan 9 V aan BATT+ aansluiting. Controleer het laadsysteem van het voertuig.

Geen geluid en BEVEILIGINGSINDICATOR is aan.

- Versterker is oververhit. Zorg ervoor dat de koeling van de versterker op de montageplaats niet is geblokkeerd. Controleer of er spanning van meer dan 16 V (of minder dan 8,5 V) op de BATT+ verbinding is. Controleer het laadsysteem van het voertuig.

Zekering van de versterker blijft doorslaan.

- De bedrading is niet juist aangesloten of er is kortsluiting. Controleer de bedravingsverbindingen.

Vervormd geluid.

- Gain is niet juist ingesteld. Controleer instelling. Controleer draden op kortsluiting of aarding. Versterker of broneenheid is mogelijk defect.

Vervormd geluid en de BEVEILIGINGSINDICATOR knippert.

- Kortsluiting in de luidspreker of de kabel. Verwijder de luidsprekerkabels één voor één om de kortgesloten luidspreker of draad te lokaliseren en te repareren.

Muziek mist dynamiek of kracht.

- De luidsprekers zijn niet juist aangesloten. Controleer de luidsprekeraansluitingen op de juiste polariteit.

Motorgeluiden (jankend of klikkend geluid) in het systeem wanneer de motor draait.

- Versterker vangt dynamorus op. Controleer eerst de aardaansluiting op de versterker - een losse of onjuiste aarde is een van de belangrijkste oorzaken van ruis. Verminder de versterking (gain). Verplaats RCA-audiokabels uit de buurt van stroomdraden. Het kan ook nodig zijn om een dynamofilter op de voedingskabel tussen batterij en dynamo te installeren.

NL



HARMAN International Industries, Incorporated 8500 Balboa Boulevard, Northridge, CA 91329 USA www.infinityspeakers.com

© 2019 HARMAN International Industries, Incorporated. Alle rechten voorbehouden.

Infinity is een handelsmerk van HARMAN International Industries, Incorporated, geregistreerd in de Verenigde Staten en / of andere landen. Functies, specificaties en ontwerp kunnen zonder voorafgaande kennisgeving worden gewijzigd.

ZAWARTOŚĆ ZESTAWU

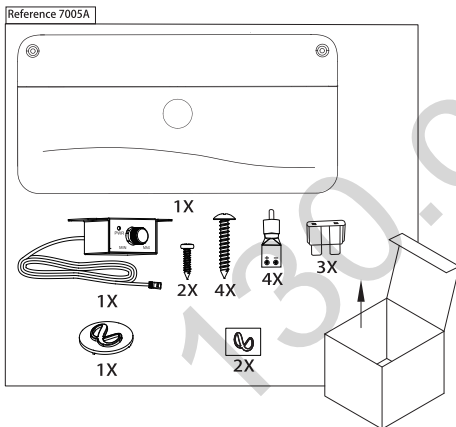
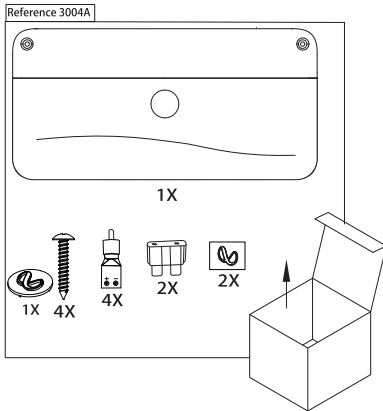

UZYSKIWANIE DOSTĘPU DO ZŁĄCZY I PANELU STEROWANIA

1. Zsuń pokrywę panelu w dół

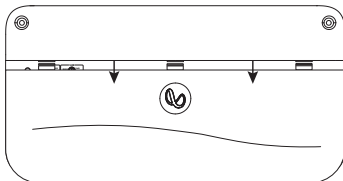

2. Usuń pokrywę panelu

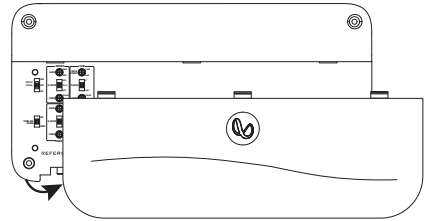

MONTAŻ WZMACNIACZA

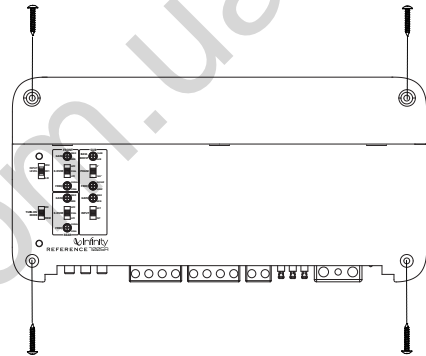

PL

Uwaga: Przed trwałym montażem wzmacniacza zaleca się wykonanie wszystkich połączeń przewodów.

WAŻNE: Odłączyć biegun ujemny akumulatora (-) przed rozpoczęciem montażu.

- Podczas korzystania z narzędzi należy zakładać środki ochrony oczu.
- Należy wybrać bezpieczną lokalizację montażową, z dala od wilgoci. Należy sprawdzić wolną przestrzeń po obu stronach powierzchni montażowej. Należy uważać, aby wkręty lub przewody elektryczne nie przebiły przewodów hamulcowych, przewodów paliwowych lub wiązek przewodów, a prowadzone przewody elektryczne nie przeszkadzały w bezpiecznym działaniu pojazdu. Zachować ostrożność podczas nawiercania otworów lub cięcia w obszarze montażowym.
- Wybrać lokalizację, która zapewnia wystarczającą cyrkulację powietrza.
- Nie należy montować wzmacniacza radiatorem skierowanym w dół, ponieważ utrudni to chłodzenie wzmacniacza.
- Zamontuj wzmacniacz tak, aby pasażerowie siedzący z tyłu nie mogli go uszkodzić stopami ani nie uszkodził go przesuwający się bagaż w bagażniku.

PRZEWODY ZASILANIA I UZIEMIENIA

Przy wzmacniaczu:

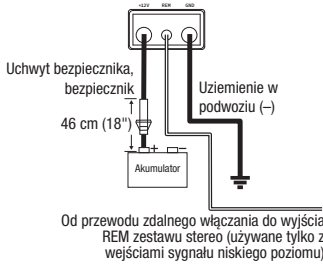

Przy uziemieniu:

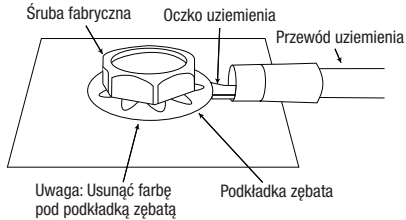

PRZEWODY DLA SYGNAŁU WEJŚCIA

Sygnaly niskiego poziomu Reference 3004A

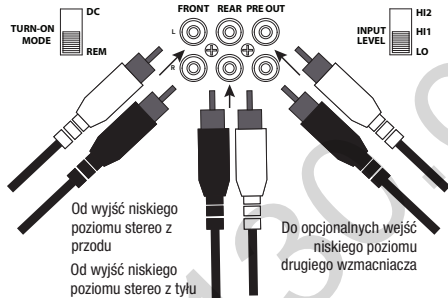

Uwaga: gdy wykorzystywane są sygnały niskiego poziomu i przewód zdalnego włączania, należy ustawić przełącznik „TURN-ON MODE” na „REM”, zaś przełącznik „INPUT LEVEL” na „LO”.

Sygnaly niskiego poziomu Reference 7005A

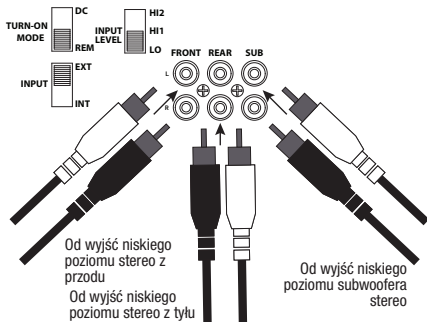

Uwaga: gdy wykorzystywane są sygnały niskiego poziomu i przewód zdalnego włączania z wzmacniaczem Reference 7005A, należy ustawić przełącznik „TURN-ON MODE” na „REM”, przełącznik SUB „INPUT” na „EXT”, zaś przełącznik „INPUT LEVEL” na „LO”.

Sygnaly wysokiego poziomu Reference 3004A

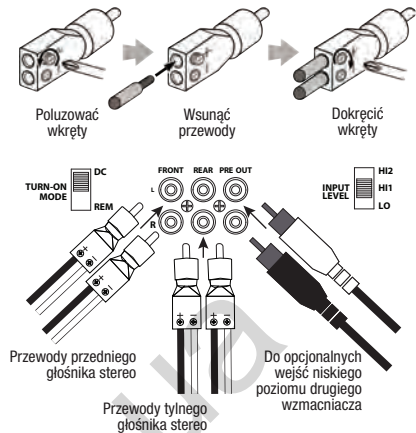

Uwaga: gdy wykorzystywane są sygnały wysokiego poziomu, należy ustawić przełącznik „TURN-ON MODE” na „DC”, zaś przełącznik „INPUT LEVEL” na „HI1”. Jeśli dźwięk nie jest odtwarzany, należy przestawić przełącznik „INPUT LEVEL” na „HI2”.

Sygnaly wejścia wysokiego poziomu Reference 7005A

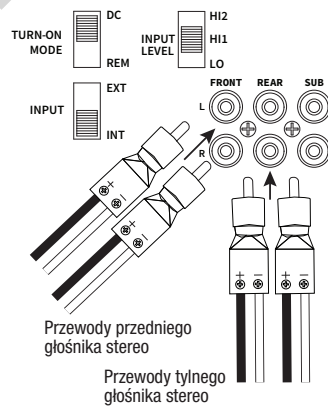

Uwaga: gdy wykorzystywane są sygnały wysokiego poziomu ze wzmacniaczem Reference 7005A, należy ustawić przełącznik „TURN-ON MODE” na „DC”, przełącznik SUB „INPUT” na „INT”, zaś przełącznik „INPUT LEVEL” na „HI1”. Jeśli dźwięk nie jest odtwarzany, należy przestawić przełącznik „INPUT LEVEL” na „HI2”.

PRZEWODY DLA WYJŚCIA

Wyjście 4-kanalowe wzmacniacza Reference 3004A (4 omy/ 2 omy)

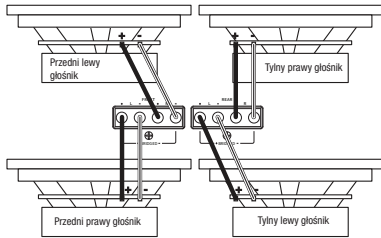

Wyjście 3-kanalowe wzmacniacza Reference 3004A (Przód: 4 omy/2 omy; tył: 4 omy)

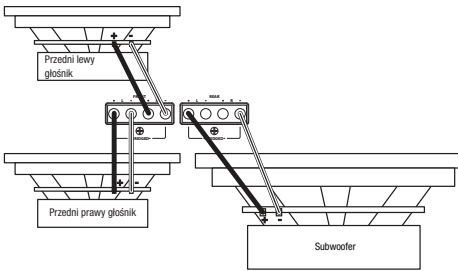

Wyjście 2-kanalowe wzmacniacza Reference 3004A (4 omy)

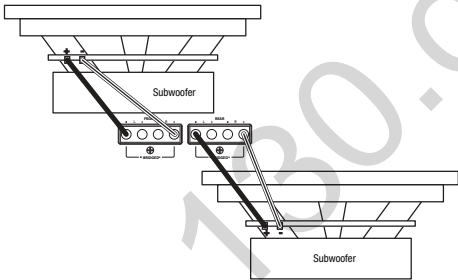

Wyjście 5-kanalowe wzmacniacza Reference 7005A (4 omy/ 2 omy)

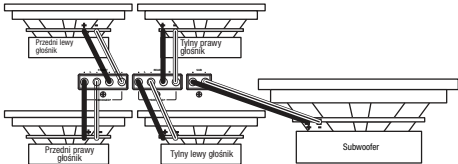

PODŁĄCZANIE PILOTA ZDALNEGO STEROWANIA NISKIMI TONAMI (TYLKO REFERENCE 7005A)

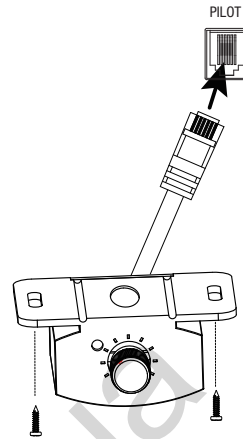

REGULOWANIE WZMOCNIENIA, ZWROTNIC I POZIOMU BASÓW

Regulowanie wzmacnienia

1. Rozpocznij od nastawienia **GAIN** na minimum; regulator zwrotnicy powinien znajdować się w położeniu środkowym.
2. Dla kanału przedniego i tylnego wybierz muzykę, którą znasz. Dla kanału subwoofera na wzmacniaczu Reference 7005A wybierz muzykę ze znaczną zawartością niskich tonów.
3. Obróć pokrętko regulacji głośności na odbiorniku do $\frac{3}{4}$ maksymalnej wartości.
4. Obróć regulator **GAIN** w prawo, nasłuchując brzmienia basów. Jeśli słyszalne są zakłócenia, obróć regulator **GAIN** w lewo.

Wybór trybu zwrotnicy

Na kanale przednim i tylnym można wybrać preferowany tryb zwrotnicy.

Wybierz HPF, aby do głośników docierał sygnał tylko o częstotliwości powyżej pewnego punktu. Jest to zalecane, jeśli w systemie audio występuje subwoofer, ponieważ utrzymywana jest niska podstawa z głośników pełnozakresowych.

Wybierz LPF, aby do głośników docierał sygnał tylko o częstotliwości poniżej pewnego punktu. Jest to zalecane, jeśli łączone są kanały przednie lub tylne dla wzmacnienia subwoofera.

Wybierz FULL, aby do głośników docierał sygnał o dowolnej częstotliwości. Jest to zalecane, jeśli w systemie audio nie ma subwoofera.

Uwaga: Tryb zwrotnicy dla kanału subwoofera wzmacniacza Reference 7005A ma charakter dolnoprzepustowy.

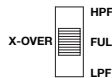

PL



Wybór częstotliwości zwrotnicy

Wybierz punkt zwrotnicy dopasowany do preferencji odsłuchu. Na skutek obrócenia pokrętki w lewo, punkt podziału zwrotnicy zostaje obniżony, a w prawo – podwyższony. Dokładne ustawienia zwrotnicy dla głośników współosiowych i subwooferów zależą od osobistego upodobania słuchacza.

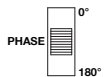

Wybór fazy subwoofera (tylko Reference 7005A)

Przełączając między PHASE, określ, które ustawienia zapewniają najczystsze tony niskie.



Wybór wzmocnienia niskich tonów (tylko Reference 7005A)

Obróć pokrętkę BASS-BOOST w prawo lub w lewo, aby dopasować wartość do swoich potrzeb.

DANE TECHNICZNE

	Reference 3004A	Reference 7005A
Moc wyjścia przy 4 omach	75 W RMS x 4	50 W RMS x 4, 320 W x 1
Moc wyjścia przy 2 omach	100 W RMS x 4	75 W RMS x 4, 500 W x 1
Moc wyjścia w trybie zmostkowanym	200 W RMS x 2 kanały przy 4 omach	150 W RMS x 2 kanały przy 4 omach
Pasma przenoszenia	10-40 kHz	10-40 kHz / 10-320 Hz
Częstotliwości graniczne	32-320 Hz zmienne, 12 dB/oktawę	32-320 Hz zmienne, górno- i dolnoprzepustowe (przód i tył); 32-320 Hz dolnoprzepustowe (subwoofer); 12 dB/oktawę
Czułość wejścia liniowego	200 mV rms – 2,0 V rms	200 mV rms – 2,0 V rms
Czułość wejścia wysokiego poziomu	2,0 Vrms – 20 Vrms	2,0 Vrms – 20 Vrms
Stosunek sygnału do szumu	> 80 dB	> 80 dB
Poziom zniekształceń harmonicznych THD+N przy mocy znamionowej	< 1%	< 1%
Obciążalność dopuszczalna bezpiecznika	30 x 2	30 x 3
Napięcie robocze	9–16 V	9–16 V
Wymiary (szer. x wys. x gł.)	12-5/8" x 2-3/16" x 7-1/8" (320 mm x 55,5 mm x 180 mm)	14-3/16" x 2-3/16" x 7-1/8" (360 mm x 56 mm x 180 mm)
Masa	3.15 kg	4.02 kg
Zalecany rozmiar przewodu	8	4

ROZWIĄZYWANIE PROBLEMÓW

Brak dźwięku, a WSKAŹNIK ZASILANIA jest wyłączony.

- Brak napięcia na zaciskach BATT+ i/lub REM lub brak/nieprawidłowe uziemienie. Sprawdzić napięcie na zaciskach wzmacniacza za pomocą miernika uniwersalnego.

Brak dźwięku, a WSKAŹNIK ZABEZPIECZENIA miga co 4 sekundy.

- Napięcie stałe na wyjściu wzmacniacza. Wzmacniacz może wymagać serwisowania; należy sprawdzić dołączoną kartę gwarancyjną w celu uzyskania informacji o serwisie technicznym.

Brak dźwięku, a WSKAŹNIKI ZASILANIA i ZABEZPIECZENIA migają.

- Napięcie na połączeniu BATT+ poniżej 9 V. Należy sprawdzić układ zasilania pojazdu.

Brak dźwięku, a WSKAŹNIK ZABEZPIECZENIA jest wyłączony.

- Wzmacniacz jest przegrzany. Należy upewnić się, że chłodzenie wzmacniacza nie zostało zablokowane. Przyczyną może również być napięcie wyższe niż 16 V (lub niższe niż 8,5 V) na połączeniu BATT+. Należy sprawdzić układ zasilania pojazdu.

Bezpiecznik wzmacniacza ciągle się przepala.

- Przewody zostały podłączone nieprawidłowo lub dochodzi do spięcia. Należy sprawdzić połączenie kabli.

Zniekształcony dźwięk.

- Czułość na wejściu nie została odpowiednio skonfigurowana. Sprawdź ustawienia. Należy sprawdzić przewody pod kątem zwarców lub przebiegów. Wzmacniacz lub urządzenie źródłowe mogą być wadliwe.

Zniekształcony dźwięk, a WSKAŹNIK ZABEZPIECZENIA miga.

- Spięcie w głośniku lub przewodzie. Należy pojedynczo odłączyć głośniki, aby określić, który głośnik/kabel powoduje spięcie, a następnie go naprawić.

Muzyce brakuje dynamiki lub „uderzenia”.

- Głośniki nie zostały prawidłowo podłączone. Należy sprawdzić głośniki pod kątem podłączenia zgodnie z biegunowością.

Hałasy silnika – gwizdy lub brzęczenie – w głośnikach przy włączonym silniku.

- Wzmacniacz wylapuje hałas alternatora. Należy sprawdzić uziemienie wzmacniacza – nieprawidłowe lub luźne uziemienie jest jedną z głównych przyczyn zakłóceń w systemie audio. Należy zmniejszyć czułość na wejściu. Należy przesunąć przewody audio RCA z dala od przewodów zasilania. Zainstalowanie filtra hałasu alternatora na przewodzie zasilania pomiędzy akumulatorem i alternatorem może być również konieczne.

PL



HARMAN International Industries, Incorporated
8500 Balboa Boulevard,
Northridge, CA 91329 USA
www.infinityspeakers.com

© 2019 Harman International Industries, Incorporated. Wszelkie prawa zastrzeżone. Infinity jest znakiem towarowym firmy HARMAN International Industries, Incorporated, zarejestrowanym w Stanach Zjednoczonych i innych krajach. Cechy, dane techniczne i wygląd produktu mogą ulec zmianie bez powiadomienia.

O QUE ESTÁ INCLUÍDO

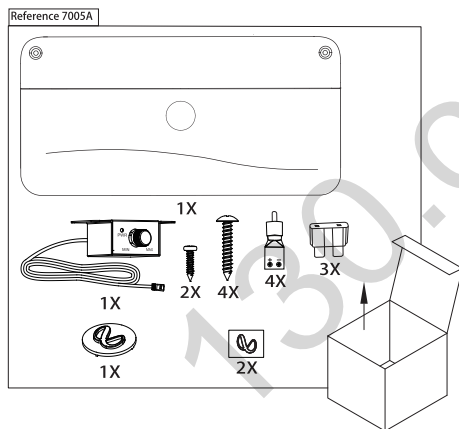
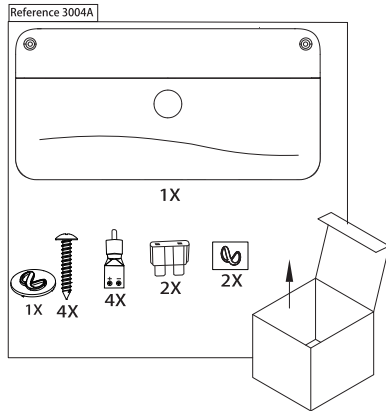

ACEDER AOS CONECTORES/PAINEL DE CONTROLO

1. Deslize a tampa do painel para baixo

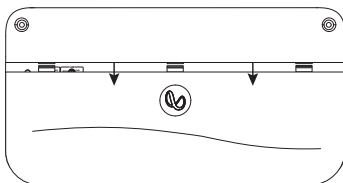

2. Retire a tampa do painel

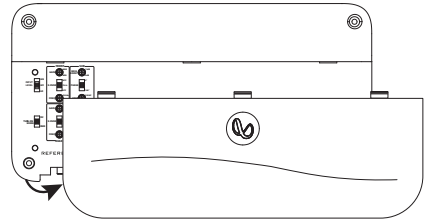

MONTAGEM DO AMPLIFICADOR

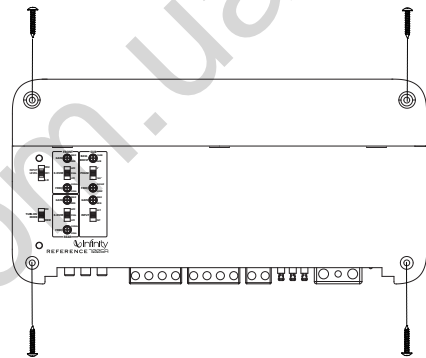

Nota: É recomendável que faça todas as ligações dos fios antes de montar o amplificador.

IMPORTANTE: Desligue o terminal negativo (-) da bateria do veículo antes de iniciar a instalação.

- Utilize sempre óculos de proteção ao usar ferramentas.
- Escolha um local de montagem seguro, afastado da humidade. Verifique as folgas nos dois lados de uma superfície de montagem planeada. Certifique-se de que os parafusos ou os fios não perfuram as linhas dos travões, as linhas de combustível ou as cablagens e que o encaminhamento dos fios não interfere com o funcionamento seguro do veículo. Tenha cuidado ao perfurar ou cortar a área de montagem.
- Escolha um local que ofereça circulação de ar suficiente.
- Não monte o amplificador com o dissipador de calor voltado para baixo, pois isso interfere com a refrigeração.
- Monte o amplificador para que não seja danificado pelos pés dos passageiros no banco traseiro ou pela movimentação de carga no porta-malas.

PT

CABLAGEM PARA ALIMENTAÇÃO E LIGAÇÃO À TERRA

No amplificador:

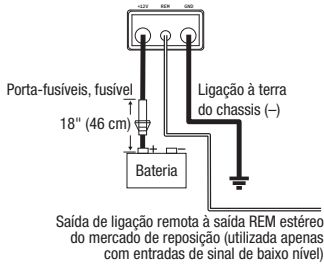

No local da ligação à terra:

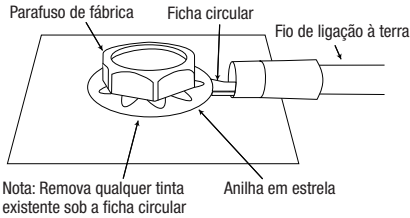

CABLAGEM PARA O SINAL DE ENTRADA

Sinais de baixo nível do Reference 3004A

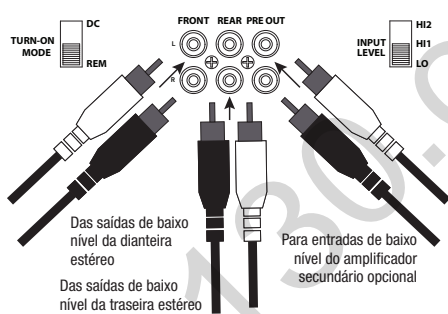

Nota: quando utilizar sinais de baixo nível e um condutor de ativação remota, coloque o interruptor "TURN-ON MODE" em "REM" e o interruptor "INPUT LEVEL" em "LO".

Sinais de baixo nível do Reference 7005A

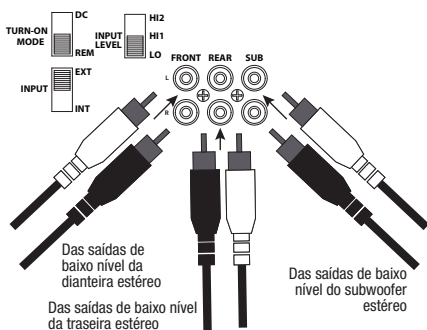

Nota: quando utilizar sinais de baixo nível e um condutor de ativação remota com o Reference 7005A, coloque o interruptor "TURN-ON MODE" em "REM", o interruptor SUB "INPUT" em "EXT" e o interruptor "INPUT LEVEL" em "LO".

Sinais de alto nível do Reference 3004A

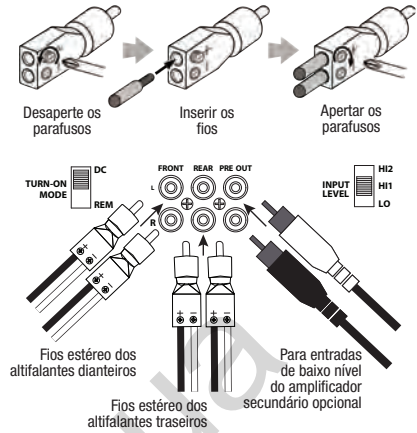

Nota: quando utilizar sinais de alto nível, coloque o interruptor "TURN-ON MODE" em "DC" e o interruptor "INPUT LEVEL" em "HI1". Se nenhum som for reproduzido, coloque o interruptor "INPUT LEVEL" em "HI2".

Sinais de entrada de alto nível do Reference 7005A

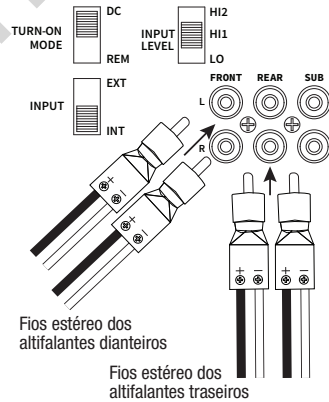

Nota: ao usar sinais de alto nível com a Referência 7005A, ajuste a chave "TURN-ON MODE" para "DC", a chave SUB "INPUT" para "INT" e a chave "INPUT LEVEL" para "HI1". Se nenhum som for reproduzido, altere a chave "INPUT LEVEL" para "HI2".

CABLAGEM PARA SAÍDA

Saída de 4 canais do Reference 3004A (4 ohm/2 ohm)

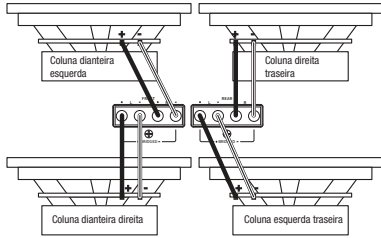

Saída de 3 canais do Reference 3004A (Dianteira: 4 ohm/2 ohm; Traseira: 4 ohm)

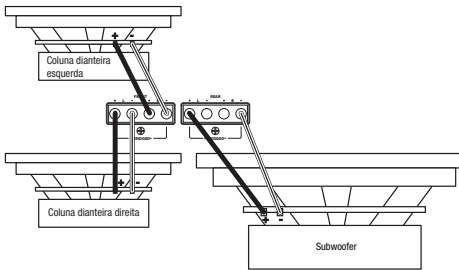

Saída de 2 canais do Reference 3004A (4 ohm)

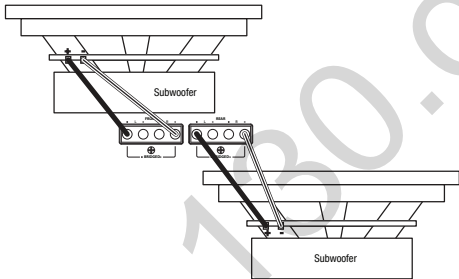

Saída de 5 canais do Reference 7005A (4 ohm/2 ohm)

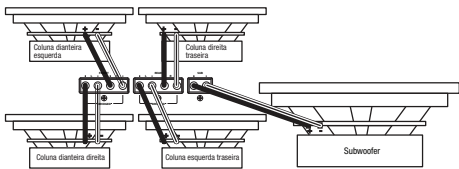

LIGAÇÃO DO COMANDO DE GRAVES (APENAS REFERENCE 7005A)

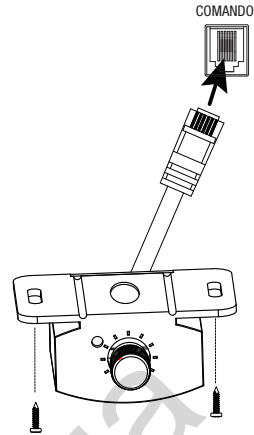

DEFINIR O GANHO, CROSSOVERS E REFORÇO DE GRAVES

Definir o ganho

1. Ligue com o controle **GAIN** definido no nível mínimo e o controle de crossover na posição central.
2. Para os canais dianteiro e traseiro, escolha músicas com as quais esteja familiarizado. Para o canal do subwoofer no Reference 7005A, escolha músicas com conteúdo substancial de graves.
3. Rode o controle de volume do seu recetor para $\frac{3}{4}$ da saída total.
4. Ajuste o controle **GAIN** para a direita, ouvindo atentamente a saída de graves. Se ouvir distorção, rode o controle **GAIN** para a esquerda para diminuir o ganho.



Selecionar o modo crossover

Nos canais dianteiro e traseiro, pode selecionar o modo crossover preferido.

Escolha HPF para permitir que apenas frequências acima de um determinado nível cheguem aos altifalantes. Recomendado se estiver a utilizar um subwoofer no seu sistema, pois mantém uma base baixa dos altifalantes de gama completa.

Escolha LPF para permitir que apenas frequências abaixo de um determinado nível cheguem aos altifalantes. Recomendado se estiver a ligar os canais frontal ou traseiro para alimentar um subwoofer.

Escolha FULL para permitir que todas as frequências cheguem aos altifalantes. Recomendado se não estiver a utilizar um subwoofer no sistema.

Nota: O modo crossover para o canal do subwoofer do Reference 7005A é apenas de passa-baixo.



PT



Selecionar a frequência de crossover

Escolha o ponto de crossover de acordo com as preferências de audição. Rode os botões para a esquerda para diminuir o crossover e para a direita para aumentar o crossover. As definições exatas de crossover para altifalantes e subwoofers coaxiais dependem das suas preferências de audição.

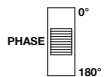

Selecionar a fase do subwoofer (apenas Reference 7005A)

Mude o PHASE para a frente e para trás para determinar que definição fornece a saída de graves mais nítida.



Selecionar o reforço de graves (apenas Reference 7005A)

Ajuste o controle BASS-BOOST para a direita ou esquerda para se adequar às suas preferências.

RESOLUÇÃO DE PROBLEMAS

Sem áudio e o INDICADOR DE ENERGIA está desligado.

- Não há tensão nos terminais BATT+ e / ou REM, má ligação ou sem ligação à terra. Verifique as tensões nos terminais do amplificador com o VOM.

Sem áudio e o INDICADOR DE PROTEÇÃO pisca a cada 4 segundos.

- Tensão CC na saída do amplificador. O amplificador pode precisar de manutenção; consulte o cartão de garantia incluído para obter informações sobre como obter assistência técnica.

Sem áudio e os INDICADORES DE PROTEÇÃO e ENERGIA piscam.

- Tensão menor que 9 V na ligação BATT+. Verifique o sistema de carregamento do veículo.

Sem áudio e o INDICADOR DE PROTEÇÃO está aceso.

- O amplificador está sobreaquecido. Verifique se a refrigeração do amplificador não está bloqueada no local de montagem. Ou pode haver tensão superior a 16 V (ou inferior a 8,5 V) na ligação BATT+. Verifique o sistema de carregamento do veículo.

O fusível do amplificador continua a fundir.

- A cablagem está ligada incorretamente ou há um curto-circuito. Verifique as ligações da cablagem.

Áudio distorcido.

- O ganho não está definido corretamente. Verifique a definição. Verifique os fios quanto a curto-circuitos ou ligação à terra. O amplificador ou a unidade de fonte pode estar com defeito.

Áudio distorcido e o INDICADOR DE PROTEÇÃO pisca.

- Curto-circuito no altifalante ou no fio. Remova os condutores do altifalante, um de cada vez, para localizar o fio ou o altifalante em curto-circuito e repare.

A música carece de dinâmica ou "intensidade".

- Os altifalantes não estão ligados corretamente. Verifique as ligações dos altifalantes quanto à polaridade adequada.

Ruído do motor - gemido ou estalidos - no sistema quando o motor está ligado.

- O amplificador está a captar o ruído do alternador. Primeiro, verifique a ligação à terra no amplificador - uma ligação à terra incorreta ou solta é uma das principais causas de ruído. Diminua o ganho. Afaste os cabos de áudio RCA dos fios de energia. Também pode ser necessária a instalação de um filtro de ruído do alternador na linha de alimentação entre a bateria e o alternador.

ESPECIFICAÇÕES

	Reference 3004A	Reference 7005A
Potência de saída a 4 ohms	75 watts RMS x 4	50 watts RMS x 4, 320 watts x 1
Potência de saída a 2 ohms	100 watts RMS x 4	75 watts RMS x 4, 500 watts x 1
Potência de saída no modo de ponte	200 watts RMS x 2 a 4 ohms	150 watts RMS x 2 a 4 ohms
Resposta em frequência	10-40 K Hz	10-40 K Hz / 10-320 Hz
Frequências de crossover	Variável de 32 a 320 Hz, 12 dB/oitava	Passa-baixo e passa-alto entre 32 e 320 Hz (dianteira e traseira); passa-baixo entre 32 e 320 Hz (subwoofer); 12 dB/oitava
Sensibilidade de entrada no nível da linha	200 mVrms – 2,0 Vrms	200 mVrms – 2,0 Vrms
Sensibilidade de entrada de alto nível	2,0 Vrms – 20 Vrms	2,0 Vrms – 20 Vrms
Relação sinal/ruído	> 80 dB	>80 dB
THD+N à potência nominal	<1%	<1%
Classificação do fusível	30 x 2	30 x 3
Tensão operacional	9–16 V	9–16 V
Dimensões (L x A x P)	12-5/8" x 2-3/16" x 7-1/8" (320 mm x 55,5 mm x 180 mm)	14-3/16" x 2-3/16" x 7-1/8" (360 mm x 56 mm x 180 mm)
Peso	3.15 kg	4.02 kg
Medição recomendada dos fios	8	4

PT



HARMAN International Industries, Incorporated
8500 Balboa Boulevard, Northridge,
CA 91329 EUA
www.infinityspeakers.com

© 2019 HARMAN International Industries, Incorporated. Todos os direitos reservados.
Infinity é uma marca comercial da HARMAN International Industries, Incorporated,
registada nos Estados Unidos da América e/ou noutros países. As características,
especificações e o aspeto estão sujeitos a alteração sem aviso prévio.

VAD FINNS I LÅDAN?

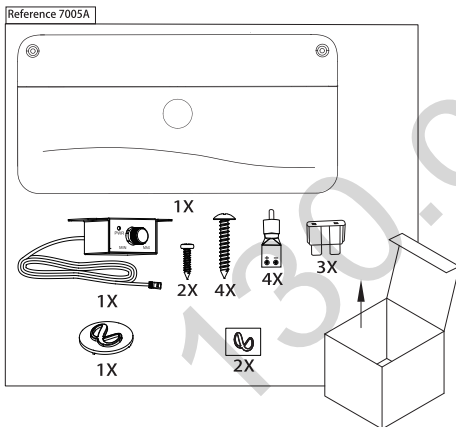
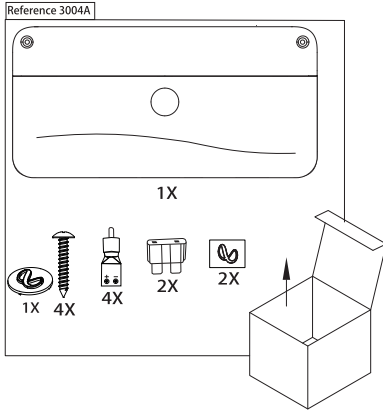

ÅTKOMST TILL ANSLUTNINGAR OCH KONTROLLPANEL

1. Drag ner panelskyddet

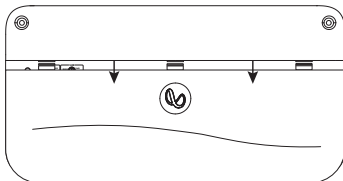

2. Avlägsna panelskyddet

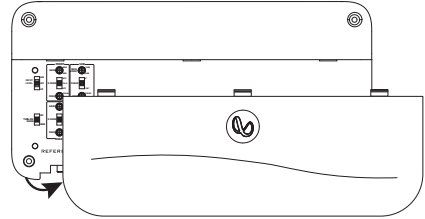

MONTERING AV FÖRSTÄRKAREN

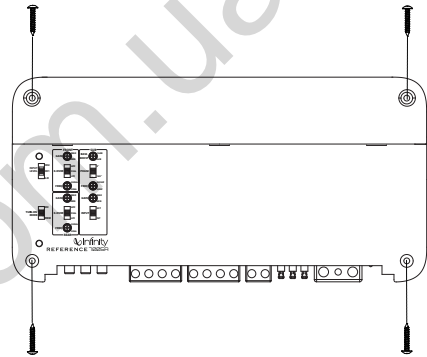

Observera: Det rekommenderas att du ansluter alla kablar innan du monterar förstärkaren.

VIKTIGT: Koppla från batteriets minuspol (-) innan du påbörjar installationen.

- Ha alltid skyddsglasögon på dig när du använder verktyg.
- Välj en säker monteringsplats som inte utsätts för fukt. Kontrollera avståndet på båda sidor av den avsedda monteringsytan. Var noga med att skruvar eller ledningar inte gör hål på bromsledningar, bränsleslangar eller elsystem och att kabeldragningen inte påverkar fordonets säkerhet. Var försiktig vid borrar eller skärning i monteringsområdet.
- Välj en plats med tillräcklig luftcirkulation.
- Montera inte förstärkaren med kylflänsen riktad nedåt, eftersom det påverkar kylningen.
- Montera förstärkaren så att den inte skadas av baksätesspassagerarnas fötter eller av last i bagageutrymmet.

SV

KABELDRAGNING FÖR STRÖM OCH JORDNING

På förstärkaren:

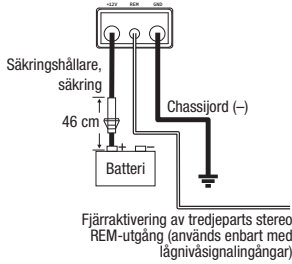

På jordningsplatsen:

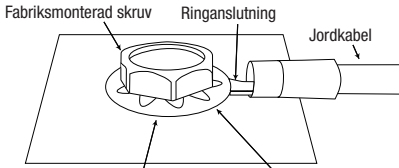

Observera: Avlägsna eventuell färg under ringanslutningen

KABLAGE FÖR INGÅNGSSIGNAL

Reference 3004A lågnivåsignaler

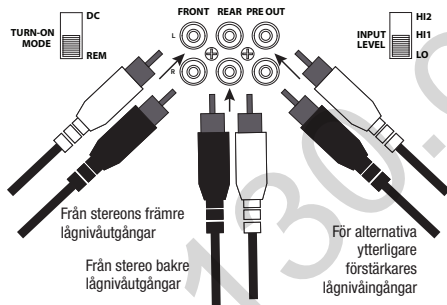

SV

Observera: när lågnivåsignaler och fjärrstyrning används, ställ in "TURN-ON MODE" till "REM" och "INPUT LEVEL" till "LO".

Reference 7005A lågnivåsignaler

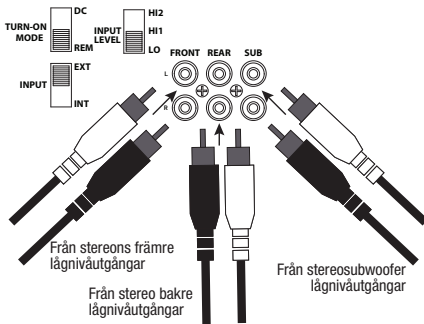

Observera: när lågnivåsignaler och fjärrstyrning används med Reference 7005A, ställ in "TURN-ON MODE" till "REM", SUB "INPUT" till "EXT" och "INPUT LEVEL" till "LO".

Reference 3004A högnivåsignaler

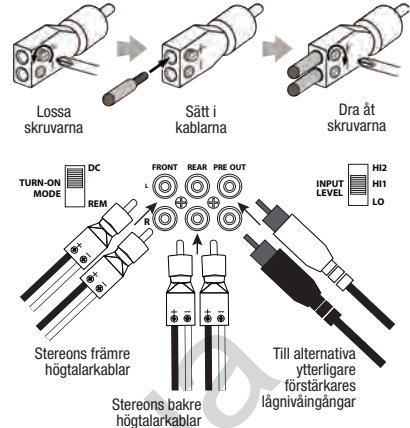

Observera: när högnivåsignaler används, ställ in "TURN-ON MODE" till läget "DC" och "INPUT LEVEL" till "HI1". Om inget ljud hörs, ändra "INPUT LEVEL" till "HI2".

Reference 7005A högnivå ingångssignaler

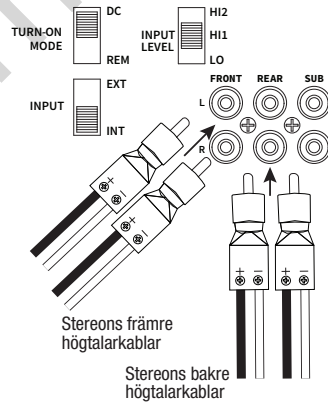

Observera: när högnivåsignaler används med Reference 7005A, ställ in "TURN-ON MODE" till läget "DC", SUB "INPUT" till "INT" och "INPUT LEVEL" till "HI1". Om inget ljud hörs, ändra "INPUT LEVEL" till "HI2".

KABELDRAGNING TILL HÖGTALARE

Reference 3004A 4-kanalsdrift (4 ohm/2 ohm)

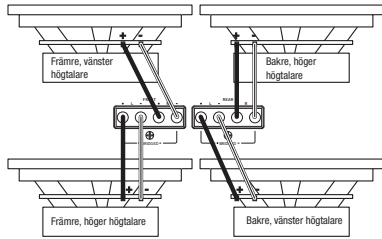

Reference 3004A 3-kanalsdrift (4 ohm/2 ohm)

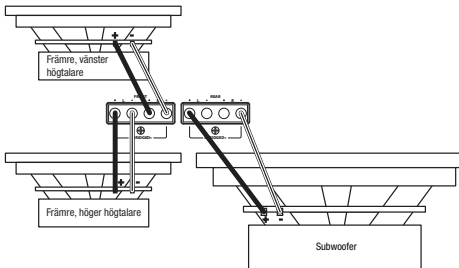

Reference 3004A 2-kanalsdrift (4 ohm)

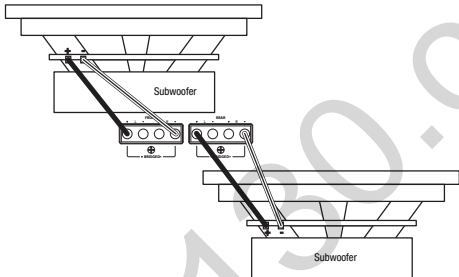

Reference 7005A 5-kanalsdrift (4 ohm/2 ohm)

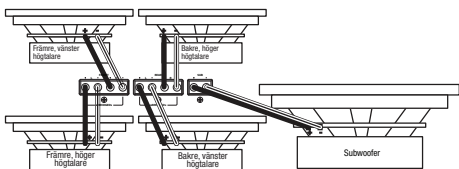

ANSLUTA BASFJÄRRKONTROLL (ENDAST REFERENCE 7005A)

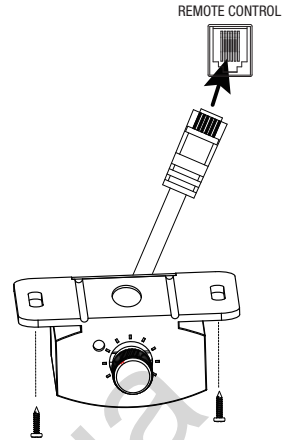

STÄLLA IN FÖRSTÄRKNING, DELNINGSFILTER OCH BASFÖRSTÄRKNING

Ställa in förstärkning

1. Börja med att ha **GAIN**-kontrollen inställd på **MIN** och kontrollen för delningsfiltret i mittenläget.
2. För främre och bakre kanaler, välj musik som du är kan bra. För subwooferkanalen i Reference 7005A, välj musik med stark bas.
3. Vrid volymkontrollen på din stereo till $\frac{3}{4}$ av maxvolymen.
4. Justera **GAIN**-kontrollen medurs och lyssna noggrant på basjudet. Om du hör förvrängning, vrid **GAIN**-kontrollen moturs för att sänka förstärkningen.



Välj delningsfilterläget

På de främre och bakre kanalerna kan du välja ditt föredragna läge för delningsfiltret.

Välj **HPF** för att tillåta frekvenser över en viss punkt att nå dina högtalare. Det rekommenderas om du använder en subwoofer i systemet, då den håller låg bas från dina fullregisterhögtalare.

Välj **LPF** för att tillåta frekvenser under en viss punkt att nå dina högtalare. Rekommenderas om du brygger de främre eller bakre kanalerna för att driva en subwoofer.

Välj **FULL** för att tillåta alla frekvenser att nå dina högtalare. Rekommenderas om du inte använder en subwoofer i ditt system.

Observera: Delningsfilterläget för subwooferkanalen på Reference 7005A är enbart lågpas.

Välja delningsfrekvens

Välj den delningsfrekvens som passar din smak. Vrid kontrollerna åt vänster för att sänka delningsfrekvensen och till höger för att höja den. De exakta inställningarna av delningsfiltret för koaxialhögtalare och subwoofer beror på vad du föredrar.



SV

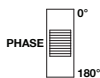

Välj subwoofer-fas (Endast Reference 7005A)

Växla PHASE fram och tillbaka för att bestämma vilken inställning som ger den senaste basen.



Välj basförstärkning (Endast Reference 7005A)

Justera BASS-BOOST känslighetskontrollen med- eller moturs för att passa din smak.

SPECIFIKATIONER

	Reference 3004A	Reference 7005A
Utteffekt @ 4 ohm	75 watt RMS x 4	50 watt RMS x 4, 320 watt x 1
Utteffekt @ 2 ohm	100 watt RMS x 4	75 watt RMS x 4, 500 watt x 1
Utteffekt i bryggat läge	200 watt RMS x 2 vid 4 ohm	150 watt RMS x 2 vid 4 ohm
Frekvensåtergivning	10 Hz-40 kHz	10 Hz-40 kHz/ 10-320 Hz
Delningsfrekvenser	Variabel 32-320 Hz, 12 dB/oktav	Variabel 32-320 Hz hög- och lågpäss (fram och bak), 32-320 Hz lågpäss (subwoofer) 12 dB/oktav
Linjeingångens känslighet	200 mVrms – 2,0 Vrms	200 mVrms – 2,0 Vrms
Högnivåns ingångskänslighet	2,0 mVrms – 20 Vrms	2,0 mVrms – 20 Vrms
Signal-brusförhållande	>80 dB	>80 dB
THD+N @ klassad effekt	< 1 %	< 1 %
Säkring	30 x 2	30 x 3
Driftspänning	9–16 V	9–16 V
Mått (B x H x D)	320 x 55,5 x 180 mm	360 x 56 x 180 mm
Vikt	3.15 kg	4.02 kg
Rekommenderad kabeltjocklek (gauge)	8	4

FELSÖKNING

Inget ljud och POWER-INDIKATORN lyser inte.

- Ingen spänning vid terminalerna BATT+ och/eller REM, alternativt dålig eller ingen jordanslutning. Kontrollera spänningen vid förstärkarens terminaler med en multimeter.

Inget ljud och PROTECT-INDIKATORN blinkar var fjärde sekund.

- Likspänning vid förstärkarutgången. Förstärkaren kan behöva service. Se bifogat garantikort för information om service.

Inget ljud och PROTECT- och POWER-INDIKATORERNA blinkar.

- Spänning under 9 V vid BATT+-anslutningen. Kontrollera fordonets laddningssystem.

Inget ljud och PROTECT-INDIKATORN lyser.

- Förstärkaren är överhettad. Se till att förstärkaren kylning inte blockeras vid monteringsplatsen. Eller så är spänningen högre än 16 V (eller lägre än 8,5 V) vid BATT+-anslutningen. Kontrollera fordonets laddningssystem.

Förstärkarens säkring löser ut upprepade gånger.

- Kabeldragningen är felaktigt gjord och det finns en kortslutning. Kontrollera kabelanslutningar.

Förvrängt ljud.

- GAIN-förstärkningen har inte ställts in korrekt. Kontrollera inställningen. Kontrollera kablarna så att det inte finns några kortslutningar eller jordfel. Det kan hända att förstärkaren eller källanheten är defekt.

Förvrängt ljud och PROTECT-INDIKATORN blinkar.

- Kortslutning i högtalare eller kabel. Avlägsna högtalarens kablar en efter en för att lokalisera den kortslutna högtalaren eller kabeln. Reparera sedan.

Musiken saknar dynamik eller "tryck".

- Högtalarna är inte ordentligt anslutna. Kontrollera att högtalaranslutningar är gjorda med rätt polaritet.

Motorljud – tjtande eller klickande – hörs i systemet när motorn är på.

- Förstärkaren fångar upp generatorljud. Kontrollera jordanslutningarna på förstärkaren – en lös eller felaktig jordanslutning är en av de vanligaste orsakerna till o ljud. Vrid ner GAIN-förstärkningen. Flytta RCA-ljudkablarna längre bort från strömkablarna. Montera ett brusfilter på strömkabeln mellan batteriet och generatormotorn kan också behövas.

SV



HARMAN International Industries,
Incorporated 8500 Balboa Boulevard,
Northridge, CA 91329 USA
www.infinityspeakers.com

© 2019 HARMAN International Industries, Incorporated. Med ensamrätt. Infinity är ett varumärke som tillhör HARMAN International Industries, Incorporated, registrerat i USA och/eller andra länder. Funktioner, specifikationer och utseende kan komma att ändras utan att detta meddelas.

KUTU İÇERİĞİ

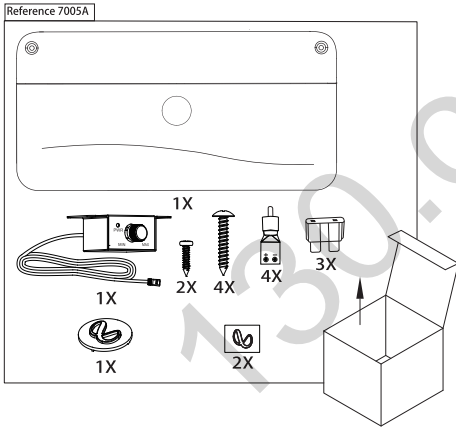
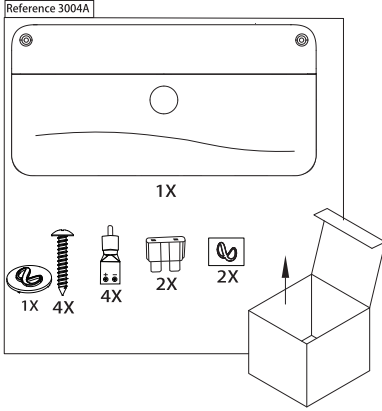

ERİŞİM BAĞLANTILARI/ KONTROL PANELİ

1. Panel kapağını aşağı kaydırın

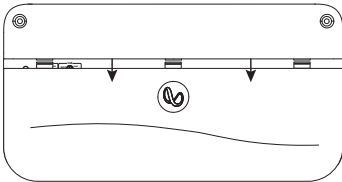

2. Panel kapağı çıkarın

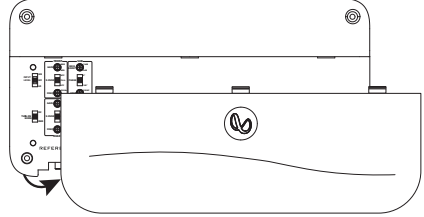

AMPLİFİKATÖRÜN MONTAJI

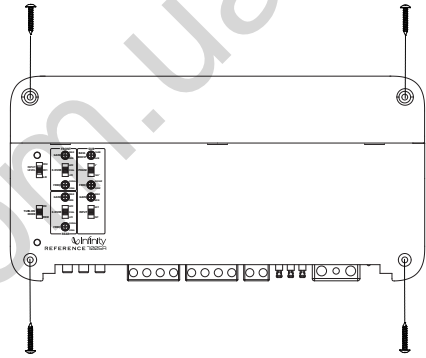

Not: Amplifikatörü monte etmeden önce, tüm kablo bağlantılarını yapmamız önerilir.

ÖNEMLİ: Kurulumu başlamadan önce aracın eksi (-) akü terminalinin bağlantısını çıkarın.

- Aletleri kullanırken her zaman koruyucu gözlük takın.
- Nemden uzak güvenli bir montaj yeri seçin. Planlanan montaj yüzeyinin her iki tarafındaki boşluklar kontrol edin. Vidaların veya tellerinin fren hatlarını, yakıt hatlarını veya kablo demetlerini delmeyeceğinden ve tel yönlendirmesinin aracın güvenli şekilde çalışmasına engel olmayacağından emin olun. Montaj alanında delik açarken veya keserken dikkatli olun.
- Yeterli hava sirkülasyonu sağlayan bir yer seçin.
- Amplifikatörü, ısı emici aşağı bakacak şekilde monte etmeyin, bu soğutma işlemini etkiler.
- Amplifikatörü, arka koltuktaki yolcuların ayaklarından veya bagajdaki kargodan zarar görmeyecek şekilde monte edin.

GÜÇ VE TOPRAKLAMA KABLOLAMA

Amplifikatörde:

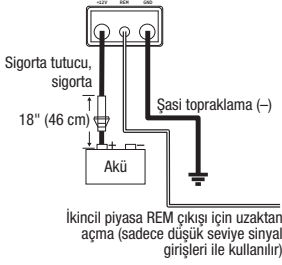

Topraklama konumunda:

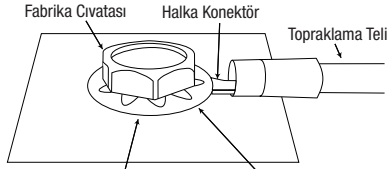

Not: Halka konektörün altındaki Yıldız Rondela tüm boyayı temizleyin.

GİRİŞ SINYALI İÇİN KABLOLAMA

Reference 3004A düşük seviye sinyalleri

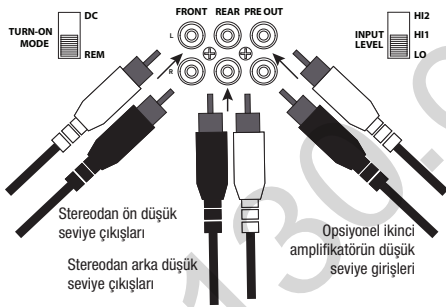

TR

Not: Düşük seviye sinyallerini ve uzaktan açma kablosunu kullanırken, "TURN-ON MODE" anahtarını "REM" ayarlayın ve "INPUT LEVEL" anahtarını "LO" ayarlayın.

Reference 7005A düşük seviye sinyalleri

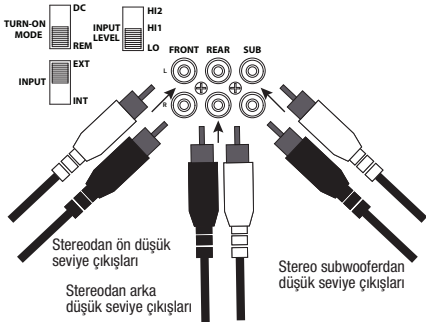

Not: 7005A ile düşük seviye sinyallerini ve uzaktan açma kablosunu kullanırken "TURN-ON MODE" anahtarını "REM" ayarlayın, SUB "INPUT" anahtarını "EXT" ayarlayın ve "INPUT LEVEL" anahtarını "LO" ayarlayın.

Reference 3004A yüksek seviye sinyalleri

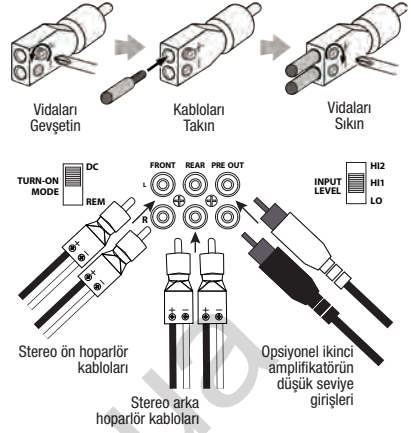

Not: Yüksek seviye sinyallerini kullanırken "TURN-ON MODE" anahtarını "DC" ayarlayın ve "INPUT LEVEL" anahtarını "HI1" e" ayarlayın. Eğer hiç ses gelmezse "INPUT LEVEL" anahtarını "HI2" değiştirin.

Reference 7005A yüksek seviye sinyalleri

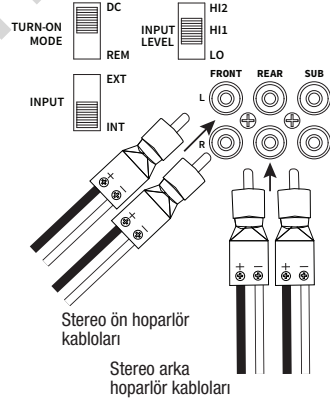

Not: Reference 7005A ile yüksek seviye sinyallerini kullanırken "TURN-ON MODE" anahtarını "DC" ayarlayın, SUB "INPUT" anahtarını "INT" ayarlayın ve "INPUT LEVEL" anahtarını "HI1" ayarlayın. Eğer hiç ses gelmezse "INPUT LEVEL" anahtarını "HI2" değiştirin.

ÇIKIŞ İÇİN KABLOLAMA

Reference 3004A 4-kanal çıkışı (4 ohm/2 ohm)

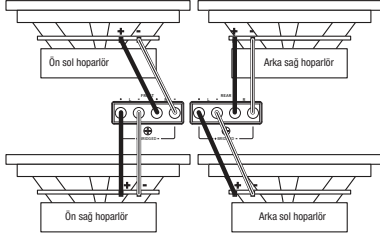

Reference 3004A 3-kanal çıkışı (Ön: 4 ohm/2 ohm; Arka: 4 ohm)

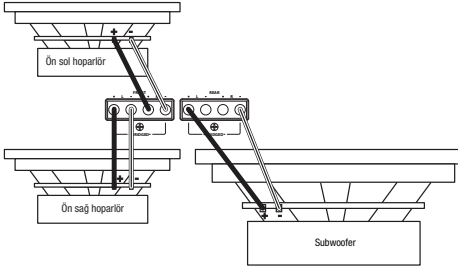

Reference 3004A 2-kanal çıkışı (4 ohm)

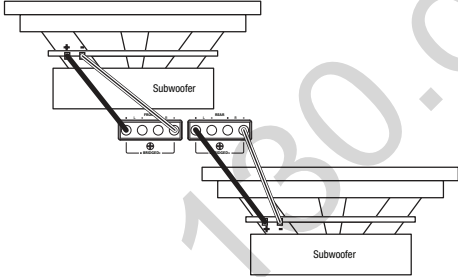

Reference 7005A 5-kanal çıkışı (4 ohm/2 ohm)

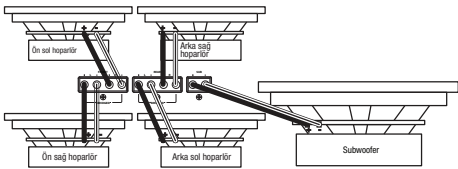

UZAKTAN BAS KONTROLÖRÜNÜ BAĞLAMA (SADECE REFERENCE 7005A)

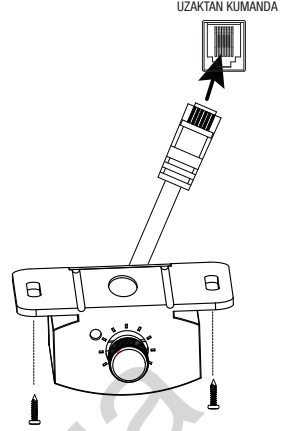

GAIN, GEÇİŞLERİ VE BAS GÜÇLENDİRME AYARI

Gain ayarı

1. **GAIN** kontrolünü en aza ayarlayarak başlayın ve geçiş kontrolü ortasına döndürülür.
2. Ön ve arka kanallar için aşına olduğunuz müziği seçin. Reference 7005A üzerindeki subwoofer kanalı için, önemli bir bas içeriğine sahip olan müzik seçin.
3. Alıcınızdaki ses kontrolünü toplam çıktısının $\frac{3}{4}$ değerine çevirin.
4. Bas çıkışı dikkatlice dinleyerek **GAIN** kontrolünü saat yönünde ayarlayın. Eğer bozulma duyarsanız, Gain'i azaltmak için **GAIN** kontrolünü saat yönünün tersine çevirin.

Geçiş frekans modunu seçme

Ön ve arka kanallarda, tercih ettiğiniz geçiş modu seçebilirsiniz.

Belirli bir noktanın üzerindeki frekansların hoparlörünüze ulaşmasına izin vermek için HPF seçin. Düşük zemini tam aralıklı hoparlörlerinizden koruduğu için sisteminizde bir subwoofer kullanıyorsanız önerilir.

Belirli bir noktanın üzerindeki frekansların hoparlörünüze ulaşmasına izin vermek için LPF seçin. Bir subwoofer'ı çalıştırmak için ön veya arka kanalları birleştiriyorsanız önerilir.

Belirli bir noktanın üzerindeki frekansların hoparlörünüze ulaşmasına izin vermek için FULL seçin. Eğer sisteminizde bir subwoofer kullanmıyorsanız önerilir.

Not: Reference 7005A subwoofer kanalı için geçiş modu sadece düşük geçişlidir.

Geçiş frekansını seçme

Dinleme tercihlerinize göre geçiş noktasını seçin. Geçiş noktasını düşürmek için kadranları sola, çaprazlama noktasını yükseltmek için sağa çevirin. Koaksiyel hoparlörler ve subwoofer için tam geçiş ayarları dinleme tercihlerinize bağlıdır.

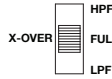

TR

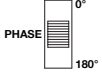

Subwoofer faz seçimi (sadece Reference 7005A)

Hangi ayarın en temiz bas çıkışını sağladığını belirlemek için PHASE ileri ve geri değiştirin.



Bas güçlendirme seçimi (sadece Reference 7005A)

BASS-BOOST kontrolünü zevkinize göre saat yönünde veya saat yönünün tersine ayarlayın.

ÖZELLİKLER

	Reference 3004A	Reference 7005A
Güç çıkışı @ 4 ohm	75 watt RMS x 4	50 watt RMS x 4, 320 watt x 1
Güç çıkışı @ 2 ohm	100 watt RMS x 4	75 watt RMS x 4, 500 watt x 1
Birleştirme modunda güç tüketimi:	200 watt RMS x 4'de 2 ohm	150 watt RMS x 4'de 2 ohm
Frekans tepkisi:	10-40 K Hz	10-40 K Hz / 10-320 Hz
Geçiş Frekansı	32-320 Hz değişken, 12 dB/oktav	32-320 Hz değişken yüksek ve düşük geçiş (ön ve arka); 32-320 Hz düşük geçiş (subwoofer); 12 dB/oktav
Hat seviyesi giriş hassasiyeti	200 mVrms – 2,0 Vrms	200 mVrms – 2,0 Vrms
Yüksek seviye giriş hassasiyeti	2,0 Vrms – 20 Vrms	2,0 Vrms – 20 Vrms
Sinyal-gürültü oranı	>80 dB	>80 dB
THD+N @ nominal güç	<1%	<1%
Sigorta değeri	30 x 2	30 x 3
Çalışma voltajı	9–16 V	9–16 V
Boyutlar (G x Y x D)	12-5/8" x 2-3/16" x 7-1/8" (320 mm x 55,5 mm x 180 mm)	14-3/16" x 2-3/16" x 7-1/8" (360 mm x 56 mm x 180 mm)
Ağırlık	3.15 kg	4.02 kg
Tavsiye edilen kablo kalınlığı	8	4

SORUN GİDERME

Ses yok ve GÜÇ GÖSTERGESİ kapalı.

- AKÜ+ ve/veya REM terminallerinde gerilim yok veya kötü ya da topraklama bağlantısı yok. Amplifikatör terminallerinde VOM ile gerilimleri kontrol edin.

Ses yok ve KORUMA GÖSTERGESİ 4 saniyede bir yanıp sönüyor.

- Amplifikatör çıkışında DC voltajı. Amplifikatörün servise gitmesi gerekebilir; servis bilgi için ekteki garanti kartına bakın.

Ses yok ve KORUMA ve GÜÇ GÖSTERGESİ yanıp sönüyor.

- AKÜ+ bağlantısında gerilim 9 V'tan az. Aracın şarj sistemini kontrol edin.

Ses yok ve KORUMA GÖSTERGESİ açık.

- Amplifikatör aşırı ısınmış. Amplifikatörün soğutmasının montaj yapılan konumunda bloke olmadığından emin olun. Ya da, AKÜ+ bağlantısında gerilim 16 V (veya 8,5 V daha az) daha fazla olabilir. Aracın şarj sistemini kontrol edin.

Amplifikatör sigortaları hep patlıyor

- Kablolar yanlış bağlanmış veya kısa devre var. Kablo bağlantılarını kontrol edin.

Bozuk ses.

- Gain Düzgün Ayarlanmamış. Ayarları Kontrol edin. Kabloların Kısa Devre veya Topraklama için Kontrol edin. Amplifikatör veya Kaynak Ünitesi Anzalı olabilir.

Bozuk Ses ve KORUMA GÖSTERGESİ yanıp sönüyor.

- Hoparlörde veya kabloda kısa devre Kısa devre yapmış hoparlör veya kabloyu bulmak için hoparlör uçlarını teker teker çıkarın ve onarın.

Müzik dinamikleri ya da "vuruşları" eksik.

- Hoparlörler düzgün bir şekilde bağlanmamış. Hoparlör bağlantılarını doğru kutuplar olduğunu kontrol edin.

Motor açıkken— sistemde motor gürültüsü — mızıltı veya tıklama var.

- Amplifikatör alternatör gürültüsünü alıyor. İlk olarak, amplifikatördeki topraklama bağlantısını kontrol edin - gevşek veya yanlış bir topraklama, gürültünün ana nedenlerinden biridir. Gain'i kısın. FCA ses kablolarını güç hatlarından uzağa taşıyın. Akü ve alternatör arasındaki güç hattına bir alternatör gürültü filtresi takılması da gerekebilir.

TR



HARMAN International Industries,
Incorporated 8500 Balboa Boulevard,
Northridge, CA 91329 USA
www.infinityspeakers.com

© 2019 HARMAN International Industries, Incorporated. Tüm hakları saklıdır. Infinity, Amerika Birleşik Devletleri ve/veya diğer ülkelerde tescilli olan HARMAN International Industries, Incorporated şirketinin ticari markasıdır. Özellikler, teknik özellikler ve görünüm, bildirim yapılmaksızın değiştirilebilir.

产品清单

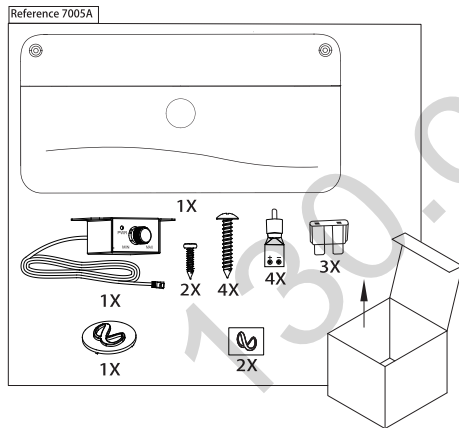
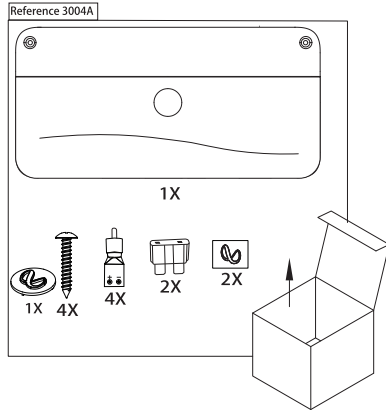

使用接口和控制面板

1. 向下滑动面板盖

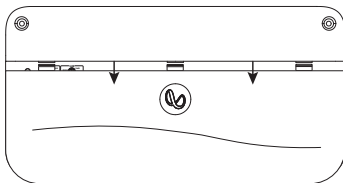

2. 取下下面板盖

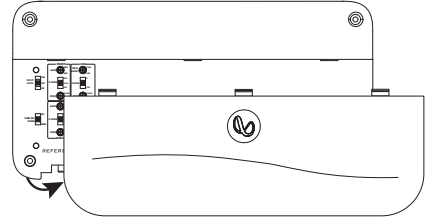

安装放大器

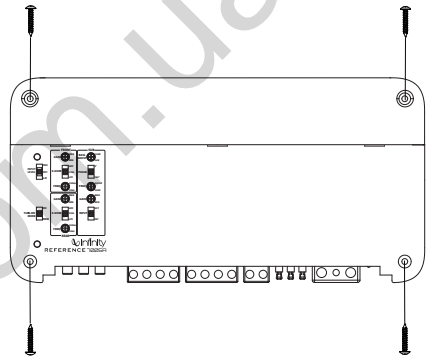

注意： 建议您在安装放大器之前完成所有导线连接。

重要提示： 开始安装前，请先断开汽车的负极 (-) 电池端子连接。

- 使用工具时，应始终佩戴护目镜。
- 选择一个安全的安装位置，避免潮湿。确认并清空安装位置表面的两侧空间。确保螺丝和电线不会刺穿制动管线、燃料管线或任何线束，且布线不会对车辆的安全驾驶造成干扰。在安装区域进行钻孔或切割时应小心谨慎。
- 选择具有足够空气流通的位置。
- 安装时请勿将散热器朝向下，以免干扰放大器冷却。
- 安装放大器时，请确保其不会被后座乘客踢碰，或因车尾箱内物品晃动而被撞坏。

ZH-CN

电源和接地接线

放大器:

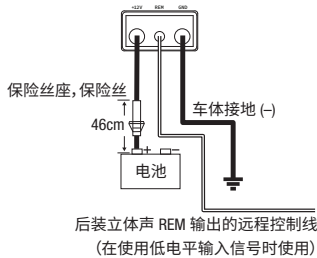

接地位置:

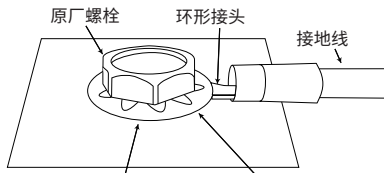

注意: 请清理环形接头下的油漆 星形垫圈

输入信号接线

Reference 3004A 低电平信号

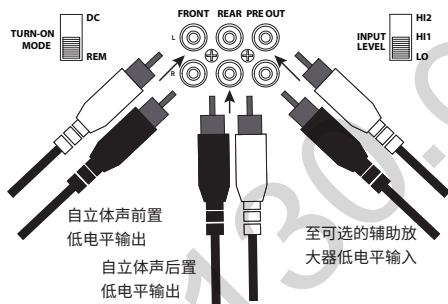

注意: 使用低电平信号和远程导通线时, 将 "TURN-ON MODE" 开关转到 "REM", 然后将 "INPUT LEVEL" 开关转到 "LO".

ZH-CN

Reference 7005A 低电平信号

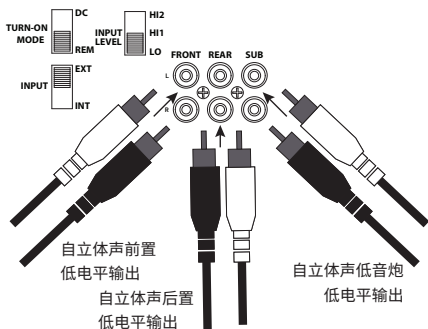

注意: 使用 Reference 7005A 以及低电平信号和远程导通线时, 将 "TURN-ON MODE" 开关转到 "REM", 将 SUB "INPUT" 开关转到 "EXT", 然后将 "INPUT LEVEL" 开关转到 "LO".

Reference 3004A 高电平信号

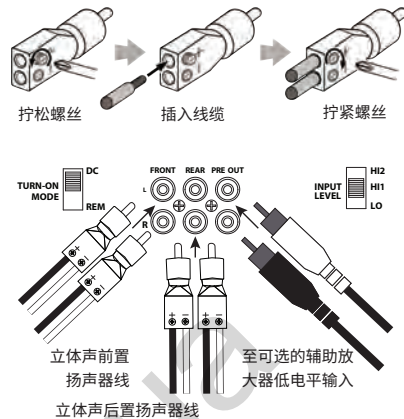

注意: 使用高电平信号时, 将 "TURN-ON MODE" 开关转到 "DC", 然后将 "INPUT LEVEL" 开关转到 "HI1". 如果没听到声音, 请将 "INPUT LEVEL" 开关转到 "HI2".

Reference 7005A 高电平输入信号

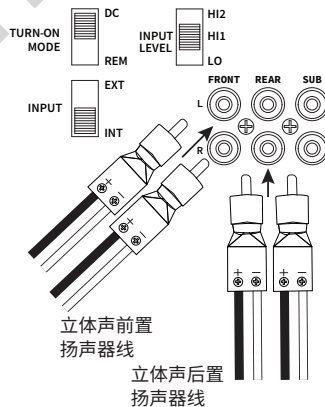

注意: 使用 Reference 7005A 和高电平信号时, 将 "TURN-ON MODE" 开关转到 "DC", 将 SUB "INPUT" 开关转到 "INT", 然后将 "INPUT LEVEL" 开关转到 "HI1". 如果没听到声音, 请将 "INPUT LEVEL" 开关转到 "HI2".

输出接线

Reference 3004A 四声道输出 (4ohm/2ohm)

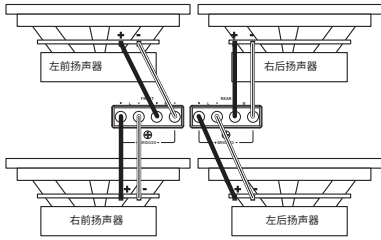

Reference 3004A 三声道输出 (前置: 4ohm/2ohm; 后置: 4ohm)

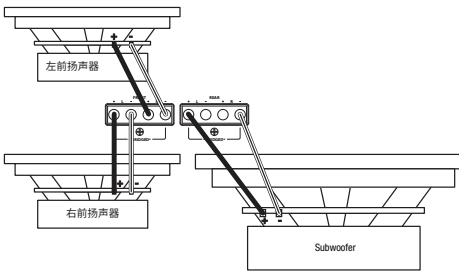

Reference 3004A 双声道输出 (4ohm)

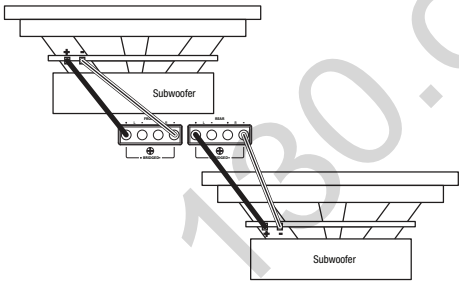

Reference 7005A 五声道输出 (4ohm/2ohm)

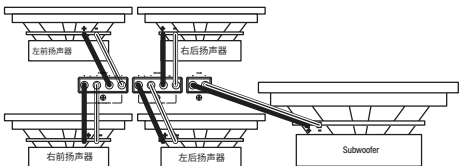

连接远程低音控制器 (仅限 REFERENCE 7005A)

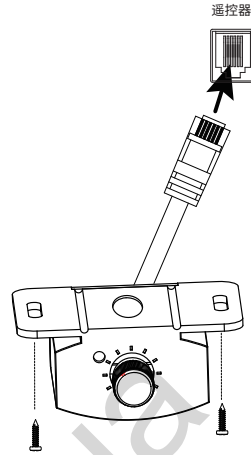

设置增益, 分频和低音增强

设置增益

1. 首先将 **GAIN** 控件设置为最小, 然后将分频控件旋转到中间位置。
2. 对于前后声道, 请播放您熟悉的音乐。对于 Reference 7005A 的低音炮声道, 请播放包含大量低音内容的音乐。
3. 将接收器上的音量控件调至其总输出的 3%。
4. 顺时针调整 **GAIN** 控件, 仔细聆听低音输出。如果听到失真, 请逆时针旋转 **GAIN** 控件以降低增益。



选择分频模式

在前后声道上, 您可以确定首选的分频模式。

选择 HPF 以只允许特定点以上的频率输出到扬声器。如果您的音响系统中包含低音炮, 则建议使用此设置, 因为它会使全频扬声器保持较少的低音。



选择 LPF 以只允许特定点以下的频率输出到扬声器。如果您要桥接前或后声道以支持低音炮, 则建议使用此设置。

选择 FULL 以允许所有频率输出到扬声器。如果您的音响系统中没有使用低音炮, 则建议使用此设置。

注意: Reference 7005A 的低音炮声道的分频模式仅为低通。

选择分频频率

选择适合聆听偏好的分频点。将旋钮拧向左边可降低分频点, 拧向右边可提高分频点。请根据您的收听偏好调整同轴扬声器和低音炮的分频设置。



ZH-CN

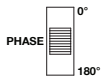

选择低音炮相位 (仅限 Reference 7005A)

来回切换 PHASE 以确定可提供最清晰低音输出的设置。



选择低音增强 (仅限 Reference 7005A)

根据自身喜好, 顺时针或逆时针调整 BASS-BOOST 控件。

规格

	Reference 3004A	Reference 7005A
功率输出 @ 4 ohms	75 W RMS x 4	50 W RMS x 4, 320 W x 1
功率输出 @ 2 ohms	100 W RMS x 4	75 W RMS x 4, 500 W x 1
桥接模式下的功率输出	200 W RMS x 2 @ 4 ohms	150 W RMS x 2 @ 4 ohms
频率响应	10-40 K Hz	10-40 K Hz / 10-320 Hz
分频频率	32-320 Hz 可变, 12 dB/倍频程	32-320 Hz 可变, 高通和低通 (前置和 后置); 32-320 Hz 低通 (低音炮); 12 dB/倍频程
线路电平输入灵敏度	200 mVrms – 2.0 Vrms	200 mVrms – 2.0 Vrms
高电平输入灵敏度	2.0 Vrms – 20 Vrms	2.0 Vrms – 20 Vrms
信噪比	> 80 dB	> 80 dB
THD+N @ 额定功率	<1%	<1%
保险丝额定电流	30 x 2	30 x 3
工作电压	9~16 V	9~16 V
尺寸 (宽 x 高 x 深)	320 mm x 55.5 mm x 180 mm	360 mm x 56 mm x 180 mm
重量	3.15 kg	4.02 kg
建议线规	8	4

故障排除

无音频且电源指示灯关闭。

- BATT+ 和/或 REM 端子没有电压, 接地线损坏或未接地。使用万用表检查放大器端子电压。

无音频且保护指示灯每 4 秒闪烁一次。

- 放大器输出直流电压故障。放大器可能需要维修; 请参阅随附保修卡以了解维修信息。

无音频且保护和电源指示灯闪烁。

- BATT+ 连接的电压小于 9V。检查汽车充电系统。

无音频且保护指示灯亮起。

- 放大器过热。确保放大器散热口未被安装位置阻挡。或者, BATT+ 连接的电压可能大于 16V (或小于 8.5V)。检查汽车充电系统。

放大器保险丝熔断。

- 线路连接不正确, 或存在短路。检查线路连接。

音频失真。

- 增益未正确设置。检查设置。检查电缆是否短路或接地不准确。放大器或源设备可能存在质量缺陷。

音频失真且保护指示灯闪烁。

- 扬声器或电线短路。一次移除一根扬声器引线, 定位短路的扬声器或电线并修理。

音乐声缺乏动态范围或“冲击力”。

- 扬声器未正确连接。检查扬声器连接的极性是否正确。

引擎启动时系统中存在引擎噪声, 如嘎嘎声或哒哒声。

- 放大器正在拾起交流发电机噪声。首先, 检查放大器的接地连接, 因为松散或错误的接地连接是引起噪声的主要原因之一。调低增益。将 RCA 音频电缆从电源线处移开。此外, 也可能需要在电池和交流发电机之间的电源线上安装交流发电机噪声滤波器。

ZH-CN



HARMAN International Industries,
Incorporated 8500 Balboa Boulevard,
Northridge, CA 91329 USA
www.infinityspeakers.com

© 2019 HARMAN International Industries, Incorporated. 保留所有权利。
Infinity 是 HARMAN International Industries, Incorporated 在美国和/或其他国家和地区的注册商标。如性能、规格及外观等有更改, 恕不另行通知。

包裝盒內物品

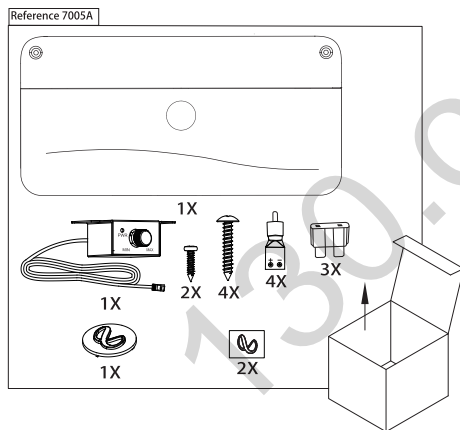
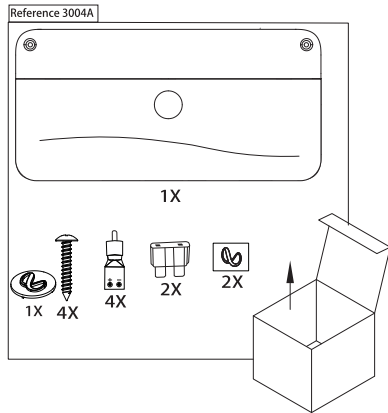

存取接口/控制面板

1. 向下滑動面板蓋

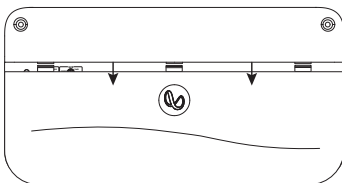

2. 取下面板蓋

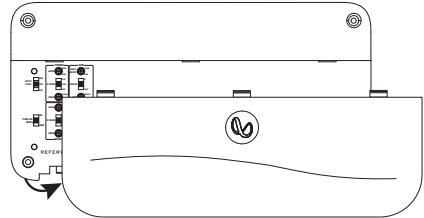

安裝功放

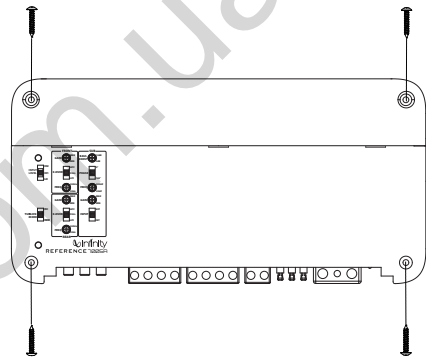

註：建議您先連接所有線纜，然後再安裝功放。

重要事項：開始安裝之前，請先斷開汽車的負極 (-) 電池端子。

- 使用工具時，請始終佩戴護目鏡。
- 選擇一個遠離濕氣的安全安裝位置。檢查計劃的安裝表面兩側的距離。請確保螺絲或電線不會刺穿制動管線、燃料管線或任何線束，以及佈線不會干擾車輛的安全操控。在安裝區域鑽孔或切割時請小心。
- 選擇提供良好空氣流通的位置。
- 安裝功放時，請勿將散熱槽正面朝下，因為這會干擾冷卻。
- 裝載功放時，請確保功放不會被後座乘客踢碰，或因車尾箱內物品晃動而損壞。

電源和接地佈線

在功效處：

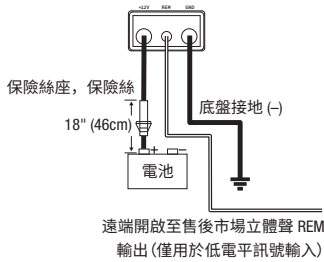

在接地位置：

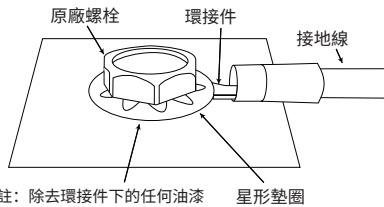

輸入訊號的接線

Reference 3004A 低電平訊號

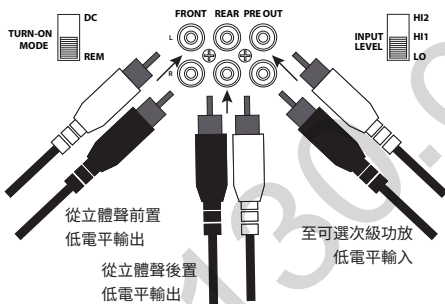

註：當使用低電平訊號和遠端開啟導線時，請將「TURN-ON MODE」開關設定為「REM」，而將「INPUT LEVEL」開關設定為「LO」。

Reference 7005A 低電平訊號

ZH-TW

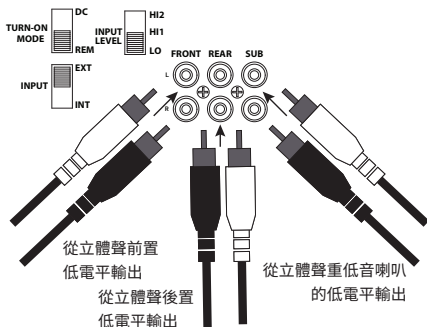

註：當使用 Reference 7005A 的低電平訊號和遠端開啟導線時，請將「TURN-ON MODE」開關設定為「REM」，並將 SUB「INPUT」開關設定為「EXT」，並將「INPUT LEVEL」開關設定為「LO」。

Reference 3004A 高電平訊號

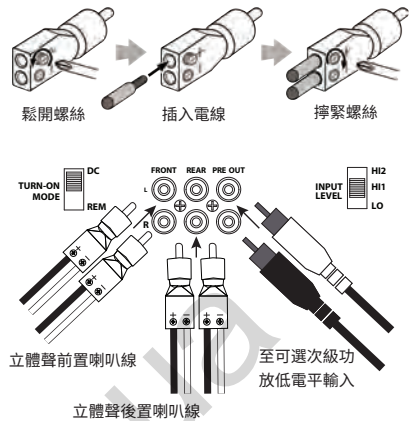

註：當使用高電平訊號時，請將「TURN-ON MODE」開關設定為「DC」，而將「INPUT LEVEL」開關設定為「HI1」。如果沒有播放聲音，請將「INPUT LEVEL」開關變更為「HI2」。

Reference 7005A 高電平輸入訊號

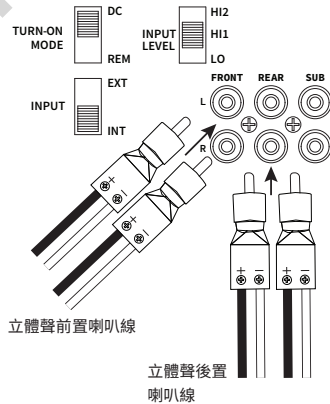

註：當使用 Reference 7005A 的高電平訊號時，請將「TURN-ON MODE」開關設定為「DC」，將 SUB「INPUT」開關設定為「INT」，並將「INPUT LEVEL」開關設定為「HI1」。如果沒有播放聲音，請將「INPUT LEVEL」開關變更為「HI2」。

輸出佈線

Reference 3004A 4 聲道輸出 (4 歐姆/2 歐姆)

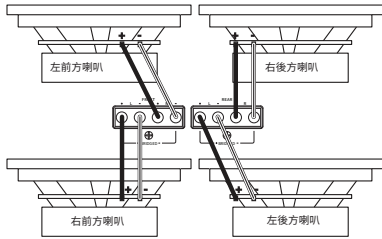

Reference 3004A 3 聲道輸出 (前置: 4 歐姆/2 歐姆; 後置: 4 歐姆)

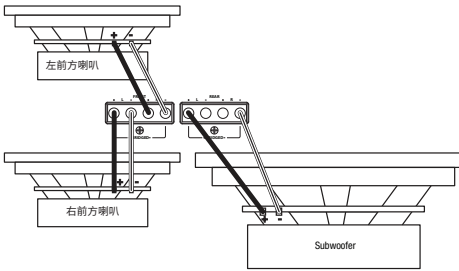

Reference 3004A 2 聲道輸出 (4 歐姆)

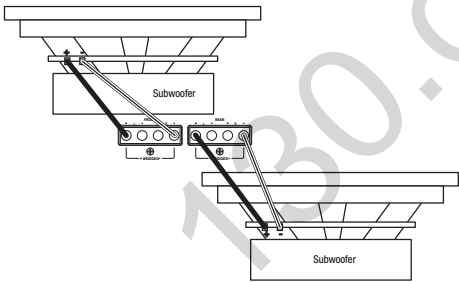

Reference 7005A 5 聲道輸出 (4 歐姆/2 歐姆)

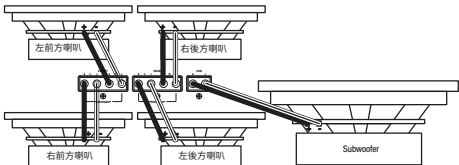

連接遠端低音控制器 (僅適用於 REFERENCE 7005A)

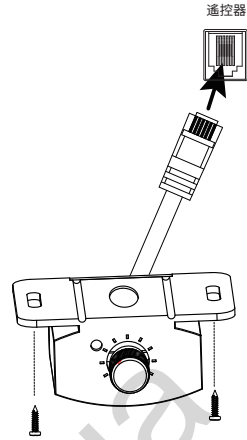

設定增益、分頻及低音加強

設定增益

1. 首先將 **GAIN** 控制鈕設為最小值，然後將分頻控制鈕轉至中間值。
2. 對於前聲道和後聲道，請選擇您熟悉的音樂。對於 Reference 7005A 上的重低音喇叭聲道，請選擇包含大量低音內容的音樂。
3. 將接收器上的音量控制鈕調到其總輸出的 $\frac{3}{4}$ 。
4. 順時針轉動 **GAIN** 控制鈕，仔細聆聽低音輸出。若您聽到了失真，則逆時針轉動 **GAIN** 控制鈕以減少增益。



選擇分頻模式

在前聲道和後聲道上，您可以選擇首選的分頻模式。

選擇 HPF 僅允許某點以上的頻率到達喇叭。在系統中使用重低音喇叭時推薦使用，因為可防止低通到達全音域喇叭。

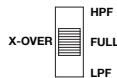

選擇 LPF 僅允許某點以下的頻率到達喇叭。在橋接前聲道或後聲道以便為重低音喇叭供電時推薦使用。

選擇 FULL 允許所有頻率到達喇叭。在系統中不使用重低音喇叭時推薦使用。

註：Reference 7005A 的重低音喇叭聲道的分頻模式僅為低通。

選擇分頻頻率

選擇分頻點以適合聆聽喜好。向左旋轉撥盤降低分頻點，向右旋轉提高分頻點。同軸喇叭和重低音喇叭的確切分頻設定取決於您的聆聽喜好。



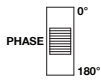

選擇重低音喇叭相位
(僅適用於 Reference 7005A)

來回切換 PHASE，以決定哪個設定可提供最清晰的低音輸出。



選擇低音加強 (僅適用於 Reference 7005A)
根據您的品味，順時針或逆時針轉動 BASS-BOOST 控制鈕。

規格

	Reference 3004A	Reference 7005A
4 歐姆時的功率輸出	75 瓦 RMS x 4	50 瓦 RMS x 4, 320 瓦 x 1
2 歐姆時的功率輸出	100 瓦 RMS x 4	75 瓦 RMS x 4, 500 瓦 x 1
橋接模式下的功率輸出	4 歐姆時 200 瓦 RMS x 2	4 歐姆時 150 瓦 RMS x 2
頻率回應	10-40 K Hz	10-40 K Hz / 10-320 Hz
分頻頻率:	32-320 Hz 可變, 12 dB/八度	32-320 Hz 可變高通 和低通 (前和後); 32-320 Hz 低通 (重低音喇叭); 12 dB //八度
線路電平輸入靈敏度	200 mVrms – 2.0 Vrms	200 mVrms – 2.0 Vrms
高電平輸入靈敏度	2.0 Vrms – 20 Vrms	2.0 Vrms – 20 Vrms
雜訊比	>80 dB	>80 dB
額定功率時的 THD+N	<1%	<1%
保險絲額定電流	30 x 2	30 x 3
工作電壓	9–16 V	9–16 V
尺寸 (寬 x 高 x 深)	12-5/8" x 2-3/16" x 7-1/8" (320 mm x 55.5 mm x 180 mm)	14-3/16" x 2-3/16" x 7-1/8" (360 mm x 56 mm x 180 mm)
重量	3.15 kg	4.02 kg
推薦電線線徑	8	4

疑難排解

無音訊並且電源指示燈關閉。

- BATT+ 和/或 REM 端子沒有電壓，或者接地連接出錯或缺失。使用伏特/歐姆計 (VOM) 檢查功放端子的電壓。

無音訊並且保護指示燈每 4 秒閃爍一次。

- 功放輸出上的 DC 電壓。功放可能需要維修；請參閱隨附的保固卡，瞭解維修資訊。

無音訊並且保護和電源指示燈閃爍。

- BATT+ 連接上的電壓低於 9V。檢查車輛的充電系統。

無音訊並且保護指示燈開啟。

- 功放過熱。確保安裝位置不會阻礙功放冷卻。或者 BATT+ 連接上可能存在大於 16V (或小於 8.5V) 的電壓。檢查車輛的充電系統。

功放保險絲總是熔斷。

- 電線連接不正確或存在短路。檢查連線。

音訊失真。

- 增益設定不正確。檢查設定。檢查電線是否短路或接地。功放或來源裝置可能存在缺陷。

音訊失真，保護指示燈閃爍。

- 喇叭內或電線短路。每次拔掉一條喇叭導線，找到短路的喇叭或電線，並進行維修。

音樂缺乏動感或「衝擊力」。

- 喇叭連接不正確。檢查喇叭連接的極性是否正確。

引擎啟動時系統中發出雜訊 (喀噠聲或高頻噪音)。

- 功放拾取交流發電機雜訊。首先，檢查功放上的接地連接 - 鬆動或不正確接地是產生雜訊的主要原因之一。調小增益。讓 RCA 音訊纜線與電源線保持一定距離。也有必要在電池和交流發電機之間的電源線上安裝交流發電機雜訊濾波器。

ZH-TW



HARMAN International Industries,
Incorporated 8500 Balboa Boulevard,
Northridge, CA 91329 USA
www.infinityspeakers.com

© 2019 HARMAN International Industries, Incorporated. 保留一切權利。
Infinity 是 HARMAN International Industries, Incorporated 在美國和/或其他國家/
地區註冊的商標。功能、規格和外觀如有變更，恕不另行通知。

ISI KOTAK

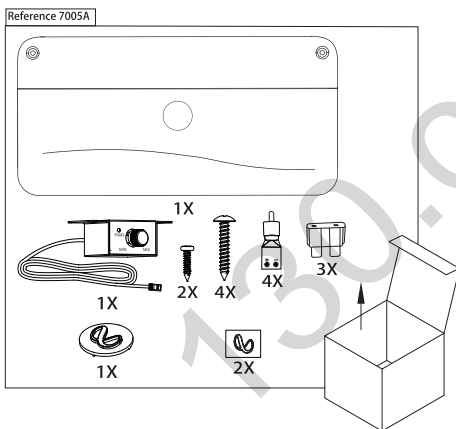
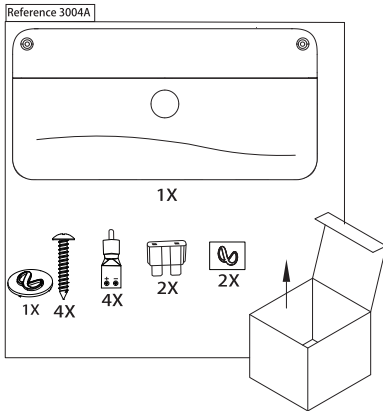

MENGAKSES KONEKTOR/PANEL KONTROL

1. Geser penutup panel ke bawah

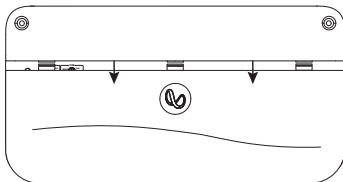

2. Lepas penutup panel

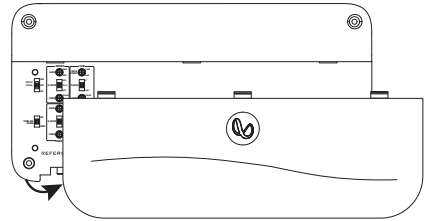

MEMASANG AMPLIFIER

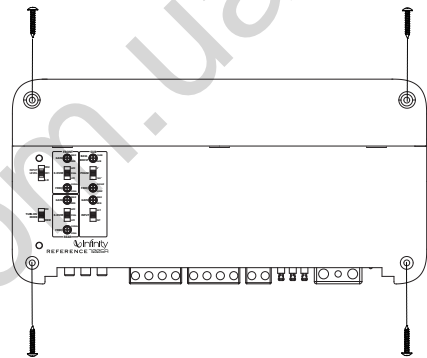

Catatan: Disarankan agar Anda menghubungkan semua kabel sebelum memasang amplifier.

PENTING: Lepaskan terminal aki negatif (-) kendaraan sebelum memulai pemasangan.

- Selalu kenakan pelindung mata saat menggunakan peralatan untuk memasang.
- Pilih lokasi pemasangan yang aman dan tidak lembap. Pastikan ketersediaan ruang pada kedua sisi permukaan pemasangan yang sudah direncanakan. Pastikan agar sekrup atau kabel tidak akan menusuk jalur rem, saluran bahan bakar, atau harness kabel, dan jalur kabel tersebut tidak akan mengganggu keamanan dalam mengoperasikan kendaraan. Berhati-hatilah saat melubangi atau memotong area duduk.
- Pilih lokasi yang memberikan sirkulasi udara yang cukup.
- Jangan memasang amplifier dengan pembuang panas menghadap ke arah bawah, karena akan mengganggu proses pendinginan.
- Pasang amplifier pada posisi sehingga tidak akan rusak akibat terinjak kaki para penumpang kursi belakang atau akibat keluar masuknya barang bawaan di ruang bagasi.

SAMBUNGAN KABEL DAYA DAN GROUND

Pada amplifier:

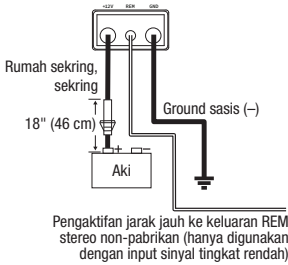

Pada lokasi ground:

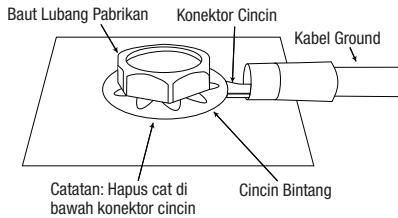

SAMBUNGAN KABEL SINYAL INPUT

Sinyal tingkat rendah Reference 3004A

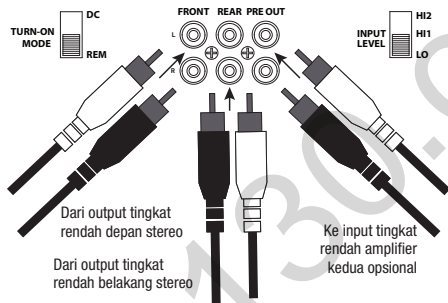

Catatan: ketika menggunakan sinyal tingkat rendah dan kabel nyalakan jarak jauh, atur sakelar "TURN-ON MODE" ke "REM" dan sakelar "INPUT LEVEL" ke "LO".

Sinyal tingkat rendah Reference 7005A

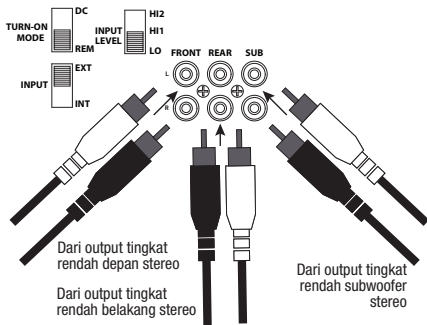

Catatan: ketika menggunakan sinyal tingkat rendah dan kabel nyalakan jarak jauh dengan Reference 7005A, atur sakelar "TURN-ON MODE" ke "REM", sakelar "INPUT" SUB ke "EXT" dan sakelar "INPUT LEVEL" ke "LO".

Sinyal tingkat tinggi Reference 3004A

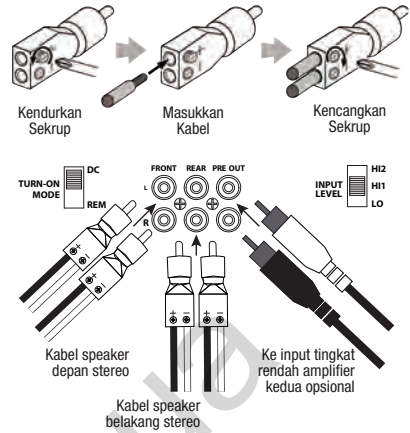

Catatan: ketika menggunakan sinyal tingkat tinggi, atur sakelar "TURN-ON MODE" ke "DC" dan sakelar "INPUT LEVEL" ke "HI1". Jika tidak ada suara, ubah sakelar "INPUT LEVEL" ke "HI2".

Sinyal input tingkat tinggi Reference 7005A

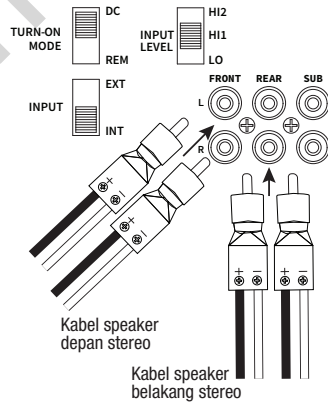

Catatan: ketika menggunakan sinyal tingkat tinggi dengan Reference 7005A, atur sakelar "TURN-ON MODE" ke "DC", sakelar "INPUT" SUB ke "INT", dan sakelar "INPUT LEVEL" ke "HI1". Jika tidak ada suara, ubah sakelar "INPUT LEVEL" ke "HI2".

SAMBUNGAN KABEL OUTPUT

Output 4 saluran Reference 3004A (4 ohm/2 ohm)

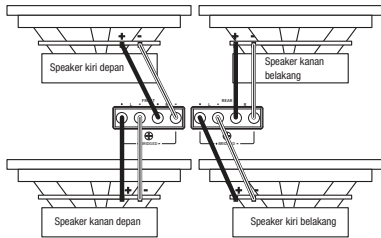

Output 3 saluran Reference 3004A (Depan: 4 ohm/2 ohm; Belakang: 4 ohm)

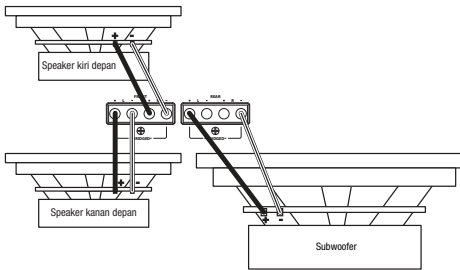

Output 2 saluran Reference 3004A (4 ohm)

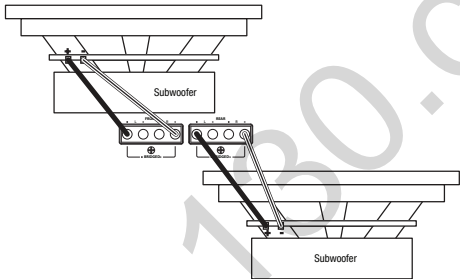

Output 5 saluran Reference 7005A (4 ohm/2 ohm)

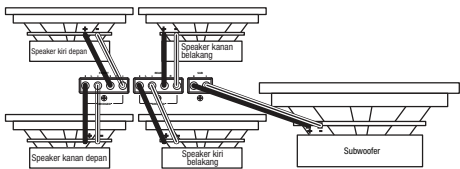

MENYAMBUNGAN PENGONTROL BAS JARAK JAUH (REFERENCE 7005A SAJA)

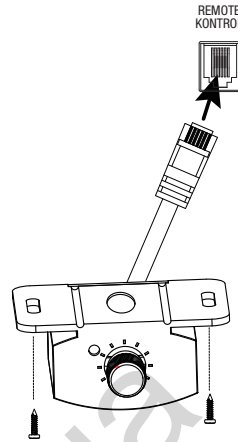

MENGATUR GAIN, CROSSOVER, DAN PENINGKAT BAS

Mengatur gain

1. Mulai dengan mengatur kontrol **GAIN** ke minimum, dan putar kontrol crossover hingga setengah putaran.
2. Untuk saluran depan dan belakang, pilih musik yang Anda kenal dengan baik. Untuk saluran subwoofer pada Reference 7005A, pilih musik dengan konten bas yang cukup kuat.
3. Putar kontrol volume pada penerima Anda hingga $\frac{3}{4}$ dari output totalnya.
4. Putar kontrol **GAIN** searah jarum jam, dengarkan output bass dengan cermat. Jika ada distorsi, putar kontrol **GAIN** berlawanan arah jarum jam untuk mengurangi gain.

Memilih mode crossover

Di saluran depan dan belakang, Anda dapat memilih mode crossover yang Anda sukai.

Pilih HPF untuk hanya mengizinkan frekuensi di atas titik tertentu untuk mencapai speaker Anda. Direkomendasikan jika Anda menggunakan subwoofer dalam sistem Anda, karena hal ini mempertahankan bas rendah dari speaker jangkauan penuh Anda.

Pilih LPF untuk hanya mengizinkan frekuensi di bawah titik tertentu untuk mencapai speaker Anda. Direkomendasikan jika Anda menjembatani saluran depan atau belakang untuk memberi daya ke subwoofer.

Pilih FULL untuk mengizinkan semua frekuensi mencapai speaker Anda. Direkomendasikan jika Anda tidak menggunakan subwoofer dalam sistem Anda.

Catatan: Mode crossover untuk saluran subwoofer Reference 7005A hanya lolos rendah.





Memilih frekuensi crossover

Pilih titik yang sesuai dengan selera pendengaran. Putar knob ke kiri untuk menurunkan titik crossover dan ke kanan untuk menaikkan titik crossover. Pengaturan crossover yang tepat untuk speaker dan subwoofer koaksial bergantung pada selera pendengaran Anda.

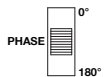

Memilih fase subwoofer (Reference 7005A saja)

Atur PHASE ke belakang dan depan untuk menentukan pengaturan mana yang menghasilkan output bas paling jernih.



Memilih peningkat bas (Reference 7005A saja)

Atur kontrol BASS-BOOST searah atau berlawanan arah jarum jam sesuai selera Anda.

SPESIFIKASI

	Reference 3004A	Reference 7005A
Output daya @ 4 ohm	75 watt RMS x 4	50 watt RMS x 4, 320 watt x 1
Output daya @ 2 ohm	100 watt RMS x 4	75 watt RMS x 4, 500 watt x 1
Output daya dalam mode dijembatani	200 watt RMS x 2 pada 4 ohm	150 watt RMS x 2 pada 4 ohm
Respons frekuensi	10-40 K Hz	10-40 KHz/ 10-320 Hz
Frekuensi crossover	32-320 Hz bervariasi, 12 dB/oktaf	32-320 Hz bervariasi lolos tinggi dan lolos rendah (depan dan belakang); 32-320 Hz lolos rendah (subwoofer); 12 dB/oktaf
Sensitivitas input tingkat baris	200 mVrms – 2,0 Vrms	200 mVrms – 2,0 Vrms
Sensitivitas input tingkat tinggi	2,0 Vrms – 20 Vrms	2,0 Vrms – 20 Vrms
Rasio sinyal-ke-derau	>80 dB	>80 dB
THD + N pada daya terukur	<1%	<1%
Peringkat sekering	30 x 2	30 x 3
Tegangan pengoperasian	9-16 V	9-16 V
Dimensi (P x T x L)	12-5/8" x 2-3/16" x 7-1/8" (320 mm x 55,5 mm x 180 mm)	14-3/16" x 2-3/16" x 7-1/8" (360 mm x 56 mm x 180 mm)
Berat	3.15 kg	4.02 kg
Ukuran kabel yang direkomendasikan	8	4

PEMECAHAN MASALAH

Tidak ada suara yang keluar dan LAMPU INDIKATOR DAYA tidak menyala.

- Tidak ada tegangan pada terminal BATT+ dan/atau REM, atau ada koneksi yang jelek atau tidak ada koneksi ground. Cek tegangan pada terminal amplifier dengan VOM.

Tidak ada suara yang keluar dan LAMPU INDIKATOR PERLINDUNGAN berkedip setiap 4 detik.

- Tegangan DC pada output amplifier. Amplifier mungkin perlu diservis; lihat kartu garansi untuk informasi servis.

Tidak ada suara yang keluar dan LAMPU INDIKATOR PERLINDUNGAN serta LAMPU INDIKATOR DAYA berkedip.

- Tegangan kurang dari 9 V pada koneksi BATT+. Periksa sistem pengisian daya kendaraan.

Tidak ada suara yang keluar dan LAMPU INDIKATOR PERLINDUNGAN menyala.

- Amplifier terlalu panas. Pastikan komponen pendingin amplifier tidak terblokir/tertutup di lokasi pemasangan. Atau, mungkin terdapat tegangan yang lebih besar dari 16 V (atau kurang dari 8,5 V) pada koneksi BATT+. Periksa sistem pengisian daya kendaraan.

Sekring amplifier cepat putus.

- Kabel tidak tersambung dengan benar atau terjadi hubungan pendek. Periksa sambungan kabel.

Ada distorsi suara pada audio.

- Gain tidak diatur sebagaimana mestinya. Periksa pengaturan. Pastikan tidak ada kondisi kabel atau ground yang menyebabkan hubungan pendek. Amplifier atau unit sumber mungkin rusak.

Ada distorsi suara pada audio dan LAMPU INDIKATOR PERLINDUNGAN berkedip.

- Ada hubungan pendek pada speaker atau kabelnya. Lepaskan kabel-kabel lead pada speaker satu per satu untuk menemukan speaker atau kabel yang mengalami hubungan pendek, lalu perbaiki.

Musik terdengar kurang dinamis atau kurang "menendang".

- Speaker tidak tersambung dengan benar. Pastikan pemasangan kutub pada sambungan speaker sudah benar.

Derau mesin – memeking atau ada suara klik-klik – di sistem saat mesin menyala.

- Amplifier meneruskan derau alternator. Pertama-tama, cek sambungan kabel ground pada amplifier – kabel ground yang longgar atau tidak benar terpasang bisa menjadi salah satu penyebab utama derau. Turunkan gain. Jauhkan kabel audio RCA dari kabel daya. Anda mungkin perlu memasang filter derau alternator di jalur daya antara aki dan alternator.

ID



HARMAN International Industries, Incorporated
8500 Balboa Boulevard,
Northridge, CA 91329 USA
www.infinityspeakers.com

© 2019 HARMAN International Industries, Incorporated. Semua hak dilindungi undang-undang.

Infinity adalah merek dagang milik HARMAN International Industries, Incorporated, yang terdaftar di Amerika Serikat dan/atau negara-negara lainnya. Fitur, spesifikasi, dan penampilan produk dapat berubah tanpa pemberitahuan.

同梱品

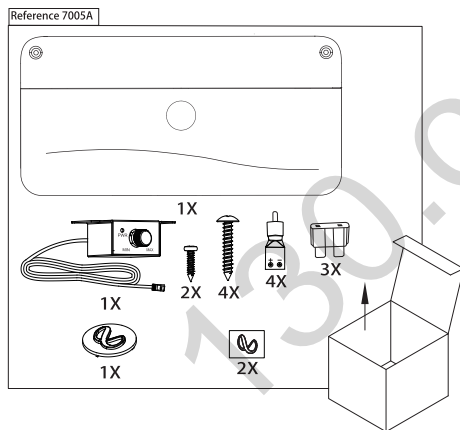
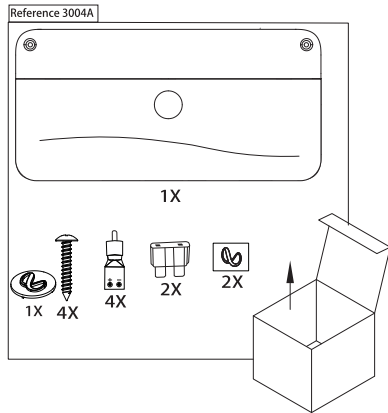

コネクタ/コントロールパネルの使用

1. パネルカバーを下にスライドさせる

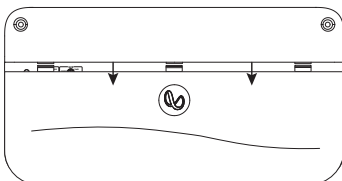

2. パネルカバーを取り外す

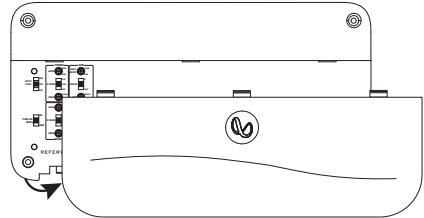

アンプの取り付け

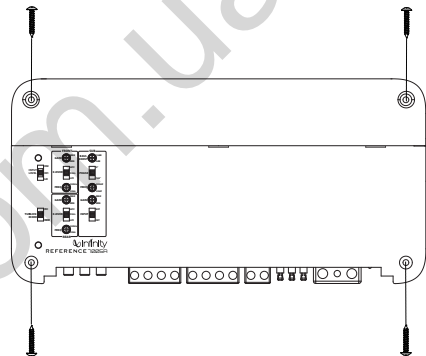

注: アンプを取り付ける前に、全ての配線を接続することをお勧めします。

重要: 設置をする前に、自動車のバッテリーマイナス(-)端子を外してください。

- 工具を使用する際は、必ず保護用の眼鏡類をかけてください。
- 湿気のない安全な場所に取り付けてください。取り付けを予定している両側に隙間があることを確認してください。ねじやワイヤーブレーキライン、燃料経路、または電機配線に穴をあけないこと。また、配線が車両の安全運転の妨げにならないことを確認してください。取付位置に穴を開けたり、またはカットする場合はご注意ください。
- 空気が十分に流れる位置を選択してください。
- 冷却の妨げになるため、放熱板が下を向いている状態でアンプを設置しないでください。
- 後部座席からの人の足や、トランクの中の荷物が移動することによって損傷することがないようにアンプを設置してください。

電源とアース用配線

アンプでの配線:

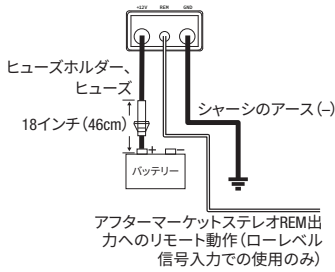

アース位置での配線:

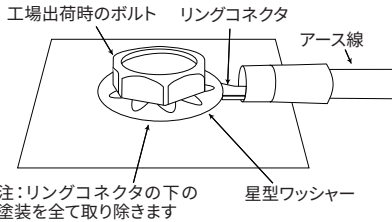

入力信号用の配線

Reference 3004Aの低レベル信号

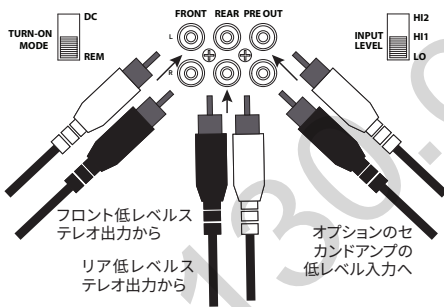

注:低レベル信号およびリモートの作動リード線を使用する場合は、「TURN-ON MODE」を「REM」に、「INPUT LEVEL」スイッチを「LO」に設定してください。

Reference 7005Aの低レベル信号

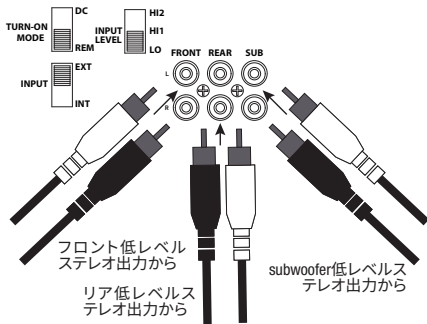

注:Reference 7005Aで、低レベル信号とリモートの作動リード線を使用する場合は、「TURN-ON MODE」スイッチを「REM」に、SUBの「INPUT」スイッチを「EXT」に、そして「INPUT LEVEL」スイッチを「LO」に設定してください。

Reference 3004Aの高レベル信号

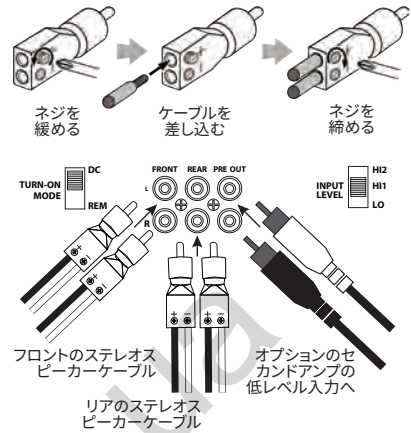

注:高レベル信号を使用する場合は、「TURN-ON MODE」スイッチを「DC」に、そして「INPUT LEVEL」スイッチを「HI1」に設定してください。サウンドが再生されない場合は、「INPUT LEVEL」スイッチを「HI2」に切り替えてください。

Reference 7005Aの高レベル入力信号

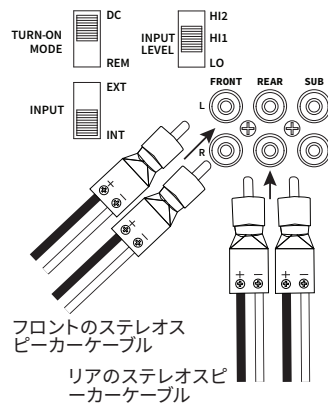

注:Reference 7005Aで、高レベル信号を使用する場合は、「TURN-ON MODE」スイッチを「DC」に、SUBの「INPUT」スイッチを「INT」に、そして「INPUT LEVEL」スイッチを「HI1」に設定してください。サウンドが再生されない場合は、「INPUT LEVEL」スイッチを「HI2」に切り替えてください。

出力用配線

Reference 3004A 4チャンネル出力 (4Ω/2Ω)

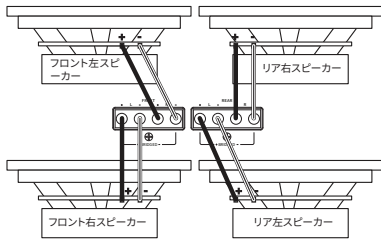

Reference 3004A 3チャンネル出力 (フロント:4Ω/2Ω, リア:4Ω)

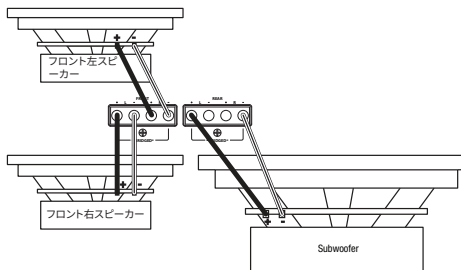

Reference 3004A 2チャンネル出力 (4Ω)

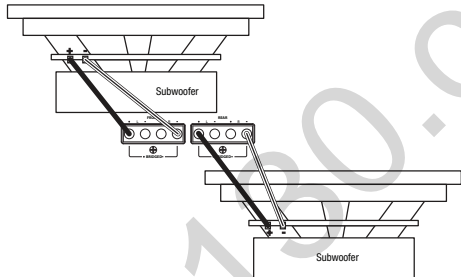

Reference 7005A 5チャンネル出力 (4Ω/2Ω)

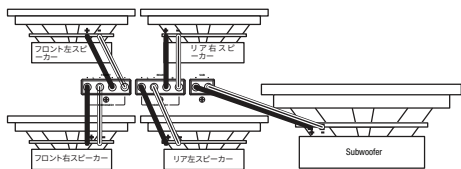

リモートバスコントローラーの接続 (REFERENCE 7005Aのみ)

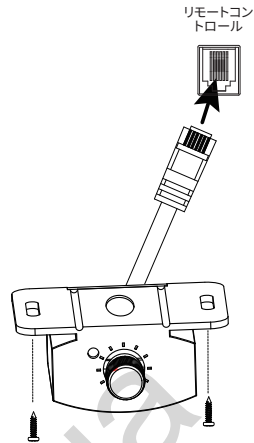

ゲイン、クロスオーバーネットワーク、バスブーストの設定

ゲインの設定

- 最初にGAINコントロールを最小にセットし、クロスオーバーコントロールを中間の位置まで回します。
- フロントとリアのチャンネル用に、なじみのある音楽を選択してください。Reference 7005Aのsubwooferチャンネル用には、なるべく低音を多く含む音楽を使います。
- レシーバーのボリュームコントロールを全出力の4分の3の位置まで回します。
- バス出力を注意深く聴きながら、GAINコントロールを時計回りに回して調節します。歪みが聞こえた場合は、GAINコントロールを反時計回りに回してゲインを減少させます。



クロスオーバーネットワークモードの選択

フロントおよびリアチャンネルで、お好みのクロスオーバーネットワークモードを選択することができます。

HPFを選択すると、特定のレベルを超える周波数のみがスピーカーに届くようになります。フルレンジスピーカーからの低音を保つことができるので、お持ちのシステムのsubwooferを使用している場合にお勧めです。



LPFを選択すると、特定のレベルを下回る周波数のみがスピーカーに届くようになります。システムでsubwooferの電源を入れて、フロント、またはリアチャンネルをブリッジさせている場合にお勧めです。

FULLを選択すると、全レベルの周波数がスピーカーに届くようになります。システムでsubwooferを使用していない場合にお勧めです。

注: Reference 7005Aのsubwooferチャンネル向けのクロスオーバーネットワークモードは、ローパスのみです。

JP

クロスオーバー周波数の選択



好みに合わせてクロスオーバーポイントを選択してください。クロスオーバーポイントを下げるには左にダイヤルを回し、上げるには右にダイヤルを回します。同軸スピーカーとsubwooferの正確なクロスオーバー設定は、好みによって決まります。

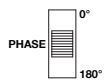

subwooferのフェーズを選択 (Reference 7005Aのみ)

PHASEを前後に切り替えて、どの設定が最も明瞭なバス出力を得られるかを決定します。

バスブーストの選択 (Reference 7005Aのみ)



お好みに合わせて、BASS-BOOSTコントロールを時計回りまたは反時計回りで調節してください。

仕様

	Reference 3004A	Reference 7005A
電源出力@4Ω	75W RMSx4	50W RMSx4、 320Wx1
電源出力@2Ω	100W RMSx4	75W RMSx4、 500Wx1
ブリッジモードでの電源出力	4Ωで200W RMSx2	4Ωで150W RMSx2
周波数特性	10~40K Hz	10~40K Hz/ 10~320Hz
クロスオーバー周波数	32~320Hz 可変式、 12dB/octave	32~320Hz可変式 ハイおよびローパス (フロントおよびリア)、 32~320Hzローパス (subwoofer)、 12dB/octave
ラインレベル入力音圧レベル	200mVrms~ 2.0Vrms	200mVrms~ 2.0Vrms
ハイレベル入力音圧レベル	2.0Vrms~20Vrms	2.0Vrms~20Vrms
S/N比:	80dBm超	80dBm超
THD+N@定格出力	1%未満	1%未満
ヒューズ定格	30x2	30x3
作動電圧	9~16 V	9~16 V
寸法 (幅x高さx奥行)	12-5/8x2-3/16x 7-1/8インチ (320mmx 55.5mmx180mm)	14-3/16x2-3/16x 7-1/8インチ (360mmx 56mmx180mm)
重量	3.15kg	4.02kg
推奨のケーブル太さ	8	4

トラブルシューティング

音が聞こえず、パワーインジケーターがオフになっている

- BATT+および/またはREM端子に電圧がかかっていない、またはアース接続が不良か、接続していません。VOMでアンプ端子の電圧をチェックします。

音が聞こえず、プロテクト・インジケーターが4秒おきに点滅する

- アンプ出力のDC電圧。アンプの点検が必要かもしれません。点検情報については、同封の保証書をご覧ください。

音が聞こえず、プロテクトおよびパワーインジケーターが点滅する

- BATT+接続の電圧が9V未満。車の充電システムをチェックしてください。

音が聞こえず、プロテクトおよびパワーインジケーターがオンになっている

- アンプがオーバーヒートしています。取付位置でアンプの冷却が阻害されていないことをご確認ください。または、BATT+接続の電圧が16Vを上回っている(または8.5V未満)可能性があります。車の充電システムをチェックしてください。

アンプのヒューズが飛んだ場合

- 配線の接続が不適切か、ショートしています。配線の接続をチェックしてください。

音が歪む

- ゲインが適切に設定されていません。設定のチェック。ショートまたはアース用のケーブルをチェックしてください。アンプまたはソースユニットに欠陥がある可能性があります。

音が歪んでプロテクト・インジケーターが点滅する

- スピーカーまたはワイヤーのショート。ショートしたスピーカーまたはワイヤーを見つけて修理するため、1本ずつスピーカーのリード線を取り外してください。

音にダイナミクシク、または「パンチ」が欠けている

- スピーカーが適切に接続されていません。スピーカー接続が適切な極性で行われていることをチェックしてください。

エンジンがかかっている場合のシステム内のエンジンノイズ(ビー、またはカチカチ音)

- アンプがオルタネーターのノイズを拾っています。緩んだ、または不適切なアースがノイズの主要因の一つなので、最初にアンプのアース接続をチェックしてください。ゲインを絞ってください。RCAオーディオケーブルを電源ケーブルから離れたところに移動させてください。バッテリーとオルタネーター間の電源ラインにオルタネーターノイズフィルターを取り付ける必要がある場合もあります。

JP



ハーマン・インターナショナル・インダストリーズ株式会社 (HARMAN International Industries, Incorporated) 8500 バルボア・ブールバード、ノースリッジ、カリフォルニア91329 米国
www.infinityspeakers.com

© 2019 HARMAN International Industries, Incorporated(ハーマン・インターナショナル・インダストリーズ株式会社)。無断複写・転載を禁じます。Infinity は、ハーマン インターナショナル インダストリーズ 株式会社 (HARMAN International Industries, Incorporated) の、米国やその他の国々の登録商標です。特徴、仕様および外観は、予告なしに変更されることがあります。

구성품

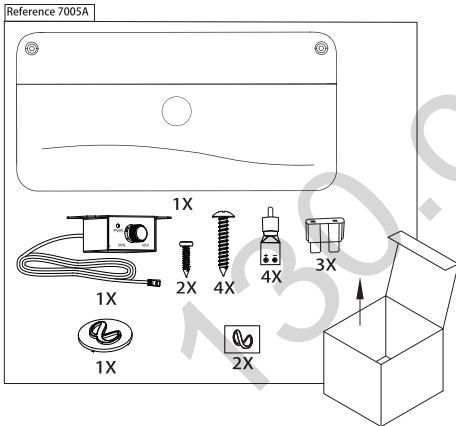
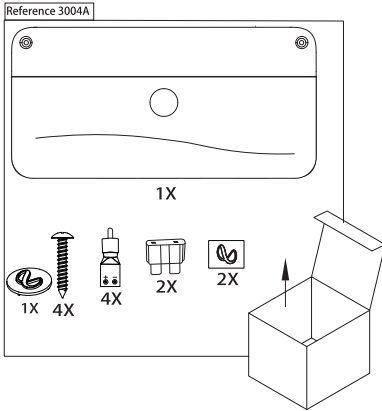

커넥터/제어 패널 접근

1. 패널 덮개를 아래로 밀니다.

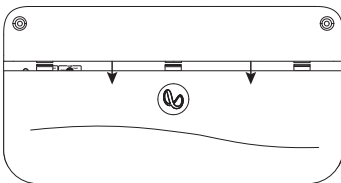

2. 패널 덮개를 분리합니다.

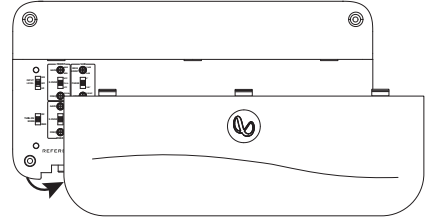

앰프 장착

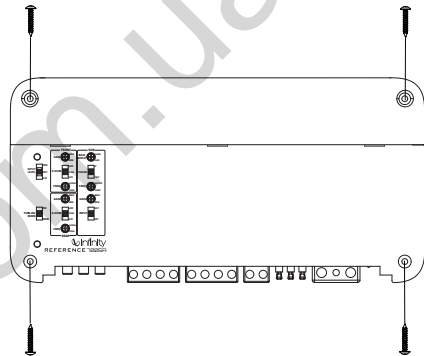

참고: 앰프를 장착하기 전 모든 배선을 연결하는 것이 좋습니다.

중요: 설치하기 전에 차량 배터리 음(-) 단자의 연결을 분리하십시오.

- 공구를 사용할 때는 반드시 눈 보호용 장비를 착용하십시오.
- 습기가 없는 안전한 장착 위치를 선택하십시오. 장착하려는 양쪽 표면의 간격을 확인합니다. 나사나 선이 브레이크 라인, 연료 라인 또는 와이어링 하니스를 뚫지 않는지, 선 배치가 차량의 안전한 작동을 방해하지 않는지 확인합니다. 장착 부위에 드릴 작업을 하거나 절단할 때는 주의하십시오.
- 공기가 충분히 순환되는 위치를 선택하십시오.
- 히트 싱크가 아래를 향하게 하여 앰프를 장착하지 마십시오. 앰프의 냉각을 방해하게 됩니다.
- 발이나 트렁크의 짐이 움직임에 따라 손상되지 않도록 앰프를 장착하십시오.

전원 및 접지 배선

엠프 측:

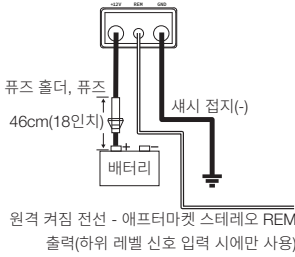

접지 위치 측:

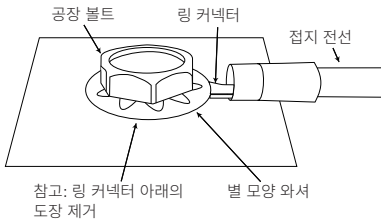

입력 신호 배선

Reference 3004A 하위 레벨 신호

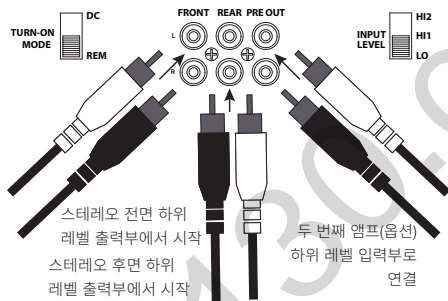

참고: 하위 레벨 신호 및 원격 켜짐 리드선을 사용하려면 "TURN-ON MODE" 스위치를 "REM"로 설정하고 "INPUT LEVEL" 스위치를 "LO"로 설정하십시오.

Reference 7005A 하위 레벨 신호

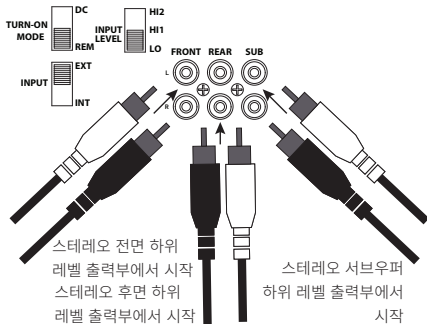

참고: 하위 레벨 신호 및 원격 켜짐 리드선을 Reference 7005A 와 함께 사용하려면 "TURN-ON MODE" 스위치를 "REM"로, SUB "INPUT" 스위치를 "EXT"로, "INPUT LEVEL" 스위치를 "LO"로 설정하십시오.

Reference 3004A 상위 레벨 신호

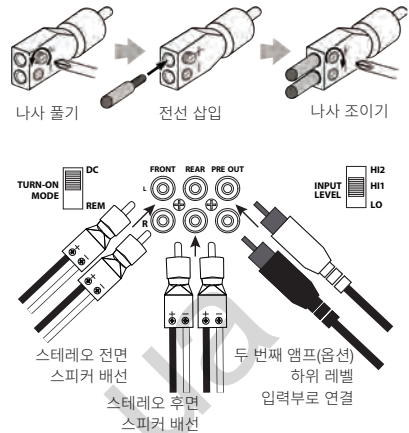

참고: 상위 레벨 신호 사용하려면 "TURN-ON MODE" 스위치를 "DC"로 설정하고 "INPUT LEVEL" 스위치를 "HI1"로 설정하십시오. 소리가 나지 않을 경우 "INPUT LEVEL" 스위치를 "HI2"로 변경하십시오.

Reference 7005A 상위 레벨 입력 신호

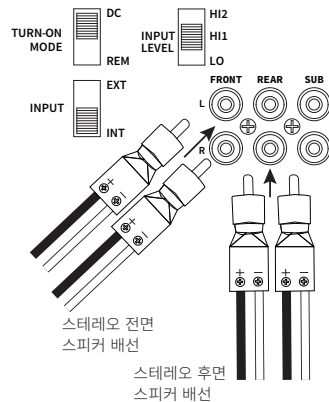

참고: 상위 레벨 신호를 Reference 7005A 와 함께 사용하려면 "TURN-ON MODE" 스위치를 "DC"로, SUB "INPUT" 스위치를 "INT"로, "INPUT LEVEL" 스위치를 "HI1"로 설정하십시오. 소리가 나지 않을 경우 "INPUT LEVEL" 스위치를 "HI2"로 변경하십시오.

출력 배선

Reference 3004A 4채널 출력(4Ω/2Ω)

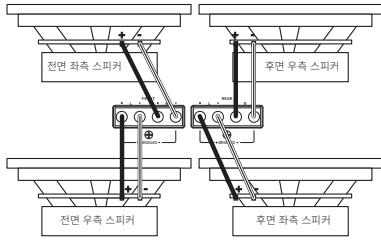

Reference 3004A 3채널 출력(전면: 4Ω/2Ω, 후면: 4Ω)

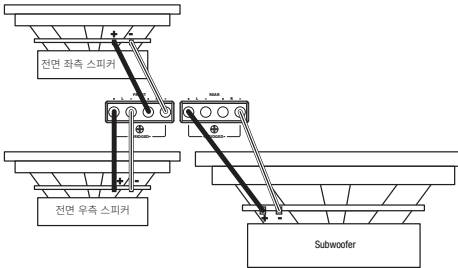

Reference 3004A 2채널 출력(4Ω)

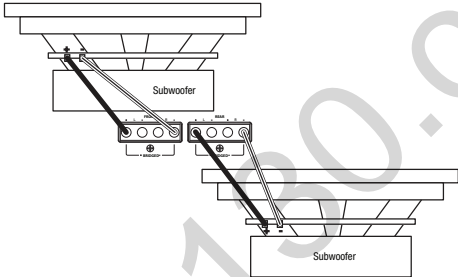

Reference 7005A 5채널 출력(4Ω/2Ω)

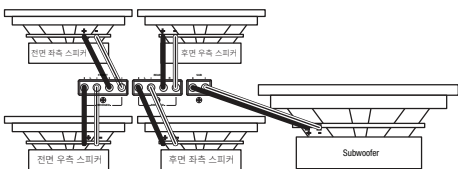

원격 저음 컨트롤러 연결(REFERENCE 7005A 만 해당)

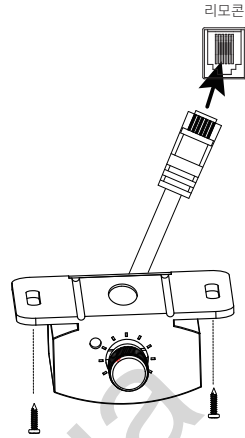

게인, 크로스오버 및 저음 부스트 설정

게인 설정

1. **GAIN** 컨트롤을 최소로 설정하고 크로스오버 제어가 중단을 향하도록 한 상태에서 시작하십시오.
2. 전면 및 후면 채널의 경우 즐겨 듣는 음악을 선택하십시오. Reference 7005A 서브우퍼 채널의 경우 강한 저음이 있는 음악을 선택하십시오.
3. 총 출력의 3/4 수준으로 리시버의 볼륨 제어를 켜십시오.
4. 저음 출력을 주의 깊게 들으면서 **GAIN** 컨트롤을 시계 방향으로 조정합니다. 왜곡이 들리면 **GAIN** 컨트롤을 시계 반대 방향으로 돌려 낮추십시오.



크로스오버 모드 선택

전면/후면 채널에서 선호하는 크로스오버 모드를 선택할 수 있습니다.

특정 지점을 초과하는 주파수만 스피커에 도달할 수 있도록 하려면 **HPF**를 선택하십시오. 시스템에서 서브우퍼를 사용하여 풀레인지 스피커에서 낮은 저음을 유지할 경우 사용할 것을 권장합니다.



특정 지점 미만의 주파수만 스피커에 도달할 수 있도록 하려면 **LPF**를 선택하십시오. 서브우퍼에 전원을 공급하기 위해 전면 또는 후면 채널을 연결하는 경우에 사용할 것을 권장합니다.

모든 주파수가 스피커에 도달할 수 있도록 하려면 **FULL**를 선택하십시오. 시스템에서 서브우퍼를 사용하지 않는 경우에 사용할 것을 권장합니다.

참고: Reference 7005A 서브우퍼 채널의 크로스오버 모드는 저음 통과 전용입니다.



크로스오버 주파수 선택

청취자의 취향에 맞게 크로스오버 지점을 선택하십시오. 다이얼을 왼쪽으로 돌리면 크로스오버 지점을 낮추고 오른쪽으로 돌리면 크로스오버 지점을 높입니다. 동축 스피커와 서브우퍼의 정확한 크로스오버 설정은 청취자의 취향에 따라 다릅니다.

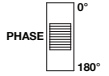

서브우퍼 위상 선택(Reference 7005A 만 해당)

PHASE 스위치를 앞뒤로 전환해 저음 출력이 가장 깨끗한 설정을 선택하십시오.



저음 부스트 선택(Reference 7005A 만 해당)

사용자의 취향에 맞춰 BASS-BOOST 제어를 시계 또는 반시계 방향으로 조정합니다.

사양

	Reference 3004A	Reference 7005A
4Ω에서 전원 출력	75W RMS x 4	50W RMS x 4, 320W x 1
2Ω에서 전원 출력	100W RMS x 4	75W RMS x 4, 500W x 1
브리지 방식 모드 의 전원 출력	200W RMS x 2(4Ω)	150W RMS x 2(4Ω)
주파수 응답	10~40kHz	10~40kHz/ 10~320Hz
크로스오버 주파수	32~320Hz 가변, 12dB/옥타브	32~320Hz 가변 고음/저음 통과(전면/ 후면), 32~320Hz 저음 통과(서브우퍼), 12dB/옥타브
라인 레벨 입력 민감도	200mVrms~2.0Vrms	200mVrms~2.0Vrms
상위 레벨 입력 민감도	2.0Vrms~20Vrms	2.0Vrms~20Vrms
신호 대 잡음비	>80dB	>80dB
정격 출력에서 THD+N	<1%	<1%
퓨즈 정격	30 x 2	30 x 3
작동 전압	9V~16V	9V~16V
치수 (너비 x 높이 x 깊이)	320mm x 55.5mm x 180mm(12-5/8" x 2-3/16" x 7-1/8")	360mm x 56mm x 180mm(14-3/16" x 2-3/16" x 7-1/8")
중량	3.15kg	4.02kg
권장하는 전선 게이지	8	4

문제 해결

오디오가 나오지 않고 전원 표시등이 꺼져 있습니다.

- BATT+ 및/또는 REM 단자가 전압이 없거나 접지 연결이 불량하거나 없습니다. VOM으로 앰프 단자의 전압을 점검하십시오.

오디오가 나오지 않고 보호 표시등이 4초마다 깜박입니다.

- 앰프 출력의 DC 전압. 앰프를 점검해야 할 수 있습니다. 서비스 정보는 동봉된 보증서를 참조하십시오.

오디오가 나오지 않고 보호, 전원 표시등이 깜박입니다.

- BATT+ 연결 전압이 9V 미만입니다. 차량 충전 시스템을 점검하십시오.

오디오가 나오지 않고 보호 표시등이 켜져 있습니다.

- 앰프가 과열되었습니다. 앰프 장착 위치에서 냉각 차단 여부를 확인하십시오. 또는 BATT+ 연결 전압이 16V를 초과했거나 8.5V 미만일 수 있습니다. 차량 충전 시스템을 점검하십시오.

앰프 퓨즈가 계속 나갑니다.

- 배선이 잘못 연결되었거나 합선되었습니다. 배선 연결을 점검하십시오.

오디오 왜곡.

- 게인이 제대로 설정되지 않았습니다. 설정을 점검하십시오. 전선의 합선이나 접지를 점검하십시오. 앰프나 소스 장치에 결함이 있을 수 있습니다.

오디오가 왜곡되고 보호 표시등이 깜박입니다.

- 스피커나 전선의 합선. 합선이 발생한 스피커나 전선을 찾기 위해 스피커 리드를 한 번에 하나씩 분리한 다음, 수리하십시오.

음악에 역동성이나 "타격감"이 부족합니다.

- 스피커가 제대로 연결되지 않았습니다. 적절한 극성으로 스피커가 연결되었는지 점검하십시오.

엔진을 켜를 때 시스템에 끼익끼하거나 딸깍하는 엔진 소음이 있습니다.

- 앰프가 교류 발전기 소음을 수신하고 있습니다. 먼저 느슨하거나 부적절한 접지는 소음의 주 원인 중 하나이므로 앰프의 접지 연결을 점검하십시오. 게인을 끕니다. RCA 오디오 케이블을 전선에서 멀리 옮기십시오. 필요 시 배터리와 교류 발전기 사이의 전선에 교류 발전기 소음 필터를 설치하십시오.

KO



HARMAN International Industries,
Incorporated 8500 Balboa Boulevard,
Northridge, CA 91329 USA
www.infinityspeakers.com

© 2019 HARMAN International Industries, Incorporated. All rights reserved.
Infinity 은 미국 및 기타 국가에 등록된 HARMAN International Industries,
Incorporated의 상표입니다. 기능, 사양 및 외관은 예고 없이 변경될 수 있습니다.

哈曼产品保修卡



机身编号

产品型号: _____

销售(安装调试)日期: 20__年__月__日

发票号码: _____ (销售者印章)

用户姓名: _____

联系电话: _____

地址(邮编): _____

重要提示:根据国家“三包”规定,您必须完整填写本凭证并与购买发票原件同时出示方可享受相关售后服务。为了保护您的权益,请您购买产品时索取合法有效的发货票并请经销商在本凭证盖具包括名称、地址、电话等信息的印章。本凭证内容与商品实物标识不符或者涂改的将不提供售后服务,请务必妥善保管。请您核对产品机身编号,编号缺失、涂改或经查询非本公司授权经销商渠道销售产品均不提供售后服务。更多信息请您阅读下面的产品保修条例。

哈曼(中国)投资有限公司

公司地址:上海市黄浦区南京西路288号3004室

中国大陆地区客服热线:400 630 6678



合格证

扫描二维码获取全国联保

产品保修期:

JBL/INFINITY汽车音响产品提供一年的保修期,自消费者在本公司授权经销商、授权安装点购买之日(即,购买发票所述的日期)起算。

保修范围:

产品在上述保修期内出现故障,且经本公司授权经销商、授权安装点或授权维修站工程师检测确认属于正常使用情况下,由于制造过程或零件损坏/失灵所导致的故障,本公司将为您提供免费修理及零件更换。

下列情形不属于保修范围

包括但不限于未按产品使用说明书要求使用(包括但不限于非汽车12V直流电源环境使用)、维护、保管而造成损坏的;经本公司授权维修者以外人员拆动、改装造成损坏的;因不可抗力(如自然灾害、虫害、雷击、等)造成损坏的;非本公司产生的运输邮寄、压烂、液体浸入、外观损坏、磨损老化等人为原因造成损坏的;已超过保修期;无保修卡及有效的购买发票,或购买发票与保修卡不符,或购买发票被涂改或无法辨认均不提供保修服务,但本公司及本公司授权维修站可按相关规定实行收费维修。

保修服务仅在中华人民共和国大陆地区有效。

由于汽车音响产品的安装属性,产品发生故障后,消费者必须先联系本产品最初的授权安装点检查并排除非产品质量原因导致的故障。无论是产品质量原因还是非质量原因导致的所有故障,均应由授权安装点负责:拆卸故障产品、送交授权维修站、装回产品的工作。

本公司不负责任何由于汽车音响产品损坏或故障而直接或间接招致的其他损失。

130.com.ua