



PHONES

0 (800) 800 130  
(050) 462 0 130  
(063) 462 0 130  
(067) 462 0 130

130  
COM.UA

Internet store of  
autogoods



SKYPE

km-130

CAR RECEIVERS — Receivers • Media receivers and stations • Native receivers • CD/DVD changers • FM-modulators/USB adapters • Flash memory • Facia plates and adapters • Antennas • Accessories |  
CAR AUDIO — Car audio speakers • Amplifiers • Subwoofers • Processors • Crossovers • Headphones • Accessories | TRIP COMPUTERS — Universal computers • Model computers • Accessories |  
GPS NAVIGATORS — Portable GPS • Built-in GPS • GPS modules • GPS trackers • Antennas for GPS navigators • Accessories | VIDEO — DVR • TV sets and monitors • Car TV tuners • Cameras • Videomodules  
• Transcoders • Car TV antennas • Accessories | SECURITY SYSTEMS — Car alarms • Bike alarms • Mechanical blockers • Immobilizers • Sensors • Accessories | OPTIC AND LIGHT — Xenon • Bixenon • Lamps  
• LED • Stroboscopes • Optic and Headlights • Washers • Light, rain sensors • Accessories | PARKTRONICS AND MIRRORS — Rear parktronic • Front parktronic • Combined parktronic • Rear-view mirrors  
• Accessories | HEATING AND COOLING — Seat heaters • Mirrors heaters • Screen-wipers heaters • Engine heaters • Auto-refrigerators • Air conditioning units • Accessories | TUNING — Vibro-isolation  
• Noise-isolation • Tint films • Accessories | ACCESSORIES — Radar-detectors • Handsfree, Bluetooth • Windowlifters • Compressors • Beeps, loudspeakers • Measuring instruments • Cleaners • Car seats  
• Miscellaneous | MOUNTING — Installation kits • Upholstery • Grilles • Tubes • Cable and wire • Tools • Miscellaneous | POWER — Batteries • Converters • Start-charging equipment • Capacitors  
• Accessories | MARINE AUDIO AND ELECTRONICS — Marine receivers • Marine audio speakers • Marine subwoofers • Marine amplifiers • Accessories | CAR CARE PRODUCTS — Additives • Washer fluid •  
Care accessories • Car polish • Flavors • Adhesives and sealants | LIQUID AND OIL — Motor oil • Transmission oil • Brake fluid • Antifreeze • Technical lubricant



In store "130" you can find and buy almost all necessary goods for your auto in Kyiv and other cities, delivery by ground and postal services. Our experienced consultants will provide you with exhaustive information and help you to chose the very particular thing. We are waiting for you at the address

<https://130.com.ua>

***Wärmeableitblech***

***Heat dissipation plate***

***Élément dissipateur de chaleur***

***Värmeavledningsplåt***

***Warmteafleidplaat***

***Panel de disipación de calor***

***Deflettore in lamiera***

***Jäähdytyslevy***



130.com.ua

3

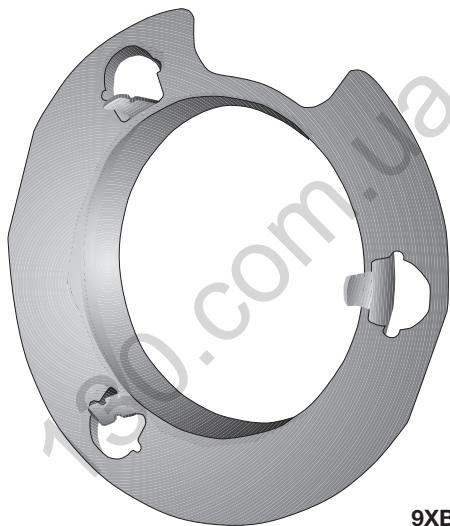

9XB 161 749-007

Autogoods "130"



4

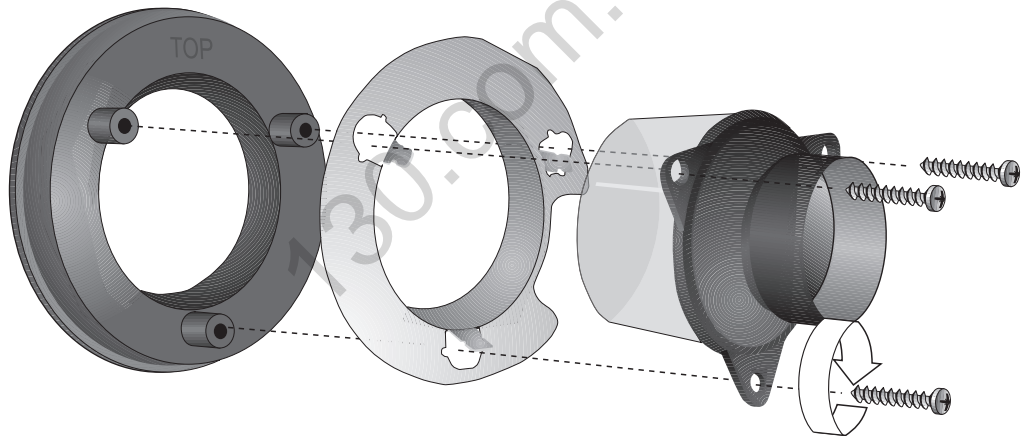

Autogoods "130"

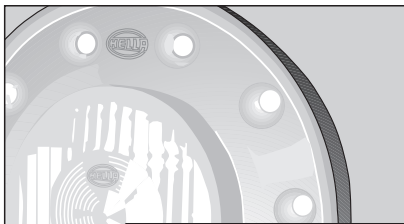

5

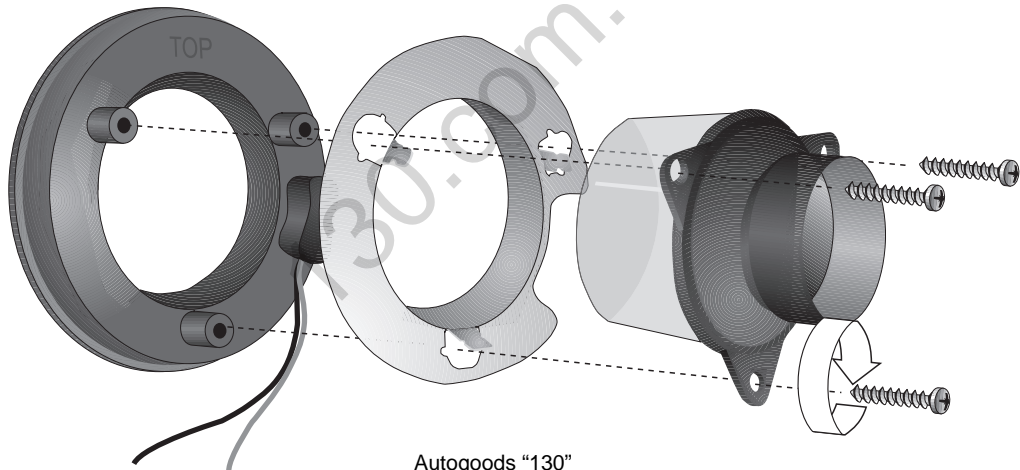

Autogoods "130"

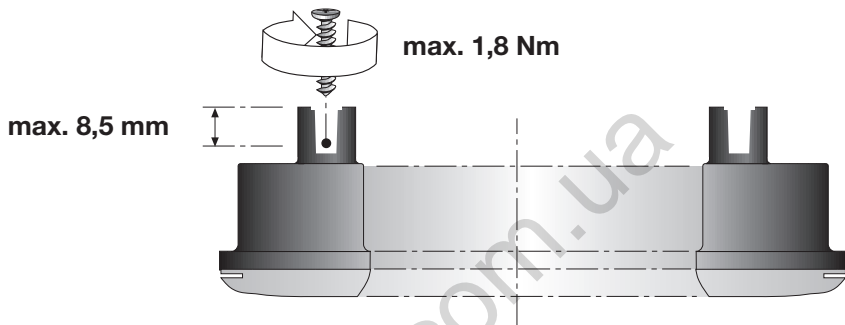

<b>DEUTSCH</b>	Technische Änderungen vorbehalten	<b>7</b>
<b>ENGLISH</b>	Subject to alteration without notice	<b>7</b>
<b>FRANÇAIS</b>	Sous réserve de modifications techniques	<b>8</b>
<b>SVENSKA</b>	Med förbehåll för tekniska förändringar	<b>8</b>
<b>NEDERLANDS</b>	Technische wijzigingen voorbehouden	<b>9</b>
<b>ESPAÑOL</b>	Reservadas modificaciones técnicas	<b>9</b>
<b>ITALIANO</b>	Con riserva di modifiche tecniche	<b>10</b>
<b>SUOMI</b>	Oikeus teknisiin muutoksiin pidätetään	<b>10</b>

## DEUTSCH



Bei Montage des Ringes 2XX 008 405-XXX im Zusammenbau mit den Leuchten 2XX 008 221-XXX ist das Wärmeableitblech zu verwenden.

Umgebungstemperatur der Leuchten darf bei Verwendung mit dem Wärmeableitblech bei bewegter Luft max. 70° C betragen.

Die Verwendung des Wärmeableitbleches ist bei einer Umgebungstemperatur > 50° C erforderlich.

### Hinweis zur Befestigung

Befestigung der Leuchte mit PT-Schrauben 4 wie Fa. Ejot. Eindrehmoment: max. 1,8 Nm  
Einschraubtiefe: max 8,5 mm

### Hinweis zur Verwendung

Anbau der Leuchte **NUR** an PKW / Bus / Caravan.  
**NICHT** geeignet für LKW (Trucks), Geländefahrzeuge, Trikes oder Quads!

### Kabelfarben und entsprechende Zuordnung

		(+)				(-)
Modell		S	S(B)	PO	blau	Masse
Spannung	12 V	schwarz	schwarz (weiß)	weiß	blau	braun
	24 V	grau	grau (rot)	rot		braun

## ENGLISH



When installing the ring 2XX 008 405-XXX with the lamps 2XX 008 221-XXX, the heat deflection shield must be used.

In the case of air in motion, an ambient temperature of the lamps of 70 °C maximum is permitted when used with the heat dissipation plate.

Use of the heat deflection shield is necessary in the case of ambient temperatures > 50 °C.

### Notes on attachment

Attach the lamp using PT screws 4 like those from Ejot  
Screwing torque max. 1.8 Nm  
Screwing depth max. 8.5 mm

### Notes on use

The lamp may **ONLY** be surface-mounted on cars / buses / caravans  
**NOT SUITABLE** for trucks, off-road vehicles, trikes or quads

### Cable colors and respective assignment

		(+)				(-)
Model		Tail lamp	Combined Tail/Stop lamp	Position light	Blue LED-module	Ground
Voltage	12 V	black	black (white)	white	blue	brown
	24 V	gray	gray (red)	red		brown



## FRANÇAIS



Lors du montage de l'enjoliveur 2XX 008 405-XXX avec les feux 2XX 008 221-XXX, la plaque de dissipation de chaleur doit être utilisée.

Si utilisé en combinaison avec une plaque de dissipation de chaleur, la température ambiante des feux ne doit pas excéder 70° C à air mouvementé.

L'utilisation de la plaque de dissipation de chaleur est nécessaire à une température ambiante > 50°C.

### Conseils pour la fixation

Fixation du feu par vis PT 4 du type Ejot.  
Couple de serrage maxi : 1,8Nm  
Profondeur de serrage maxi : 8,5 Nm

### Conseils pour l'affectation

Montage appliqué du feu **UNIQUE-MENT** sur VL / bus / camping-cars **NON ADAPTÉ** aux PL, véhicules tout-terrain, trikes ou quads!

### Couleurs des câbles et affectation

Modèle		(+) (+)				(-)
		Feu AR	Feu AR/feu stop	Feu de position	Module LED bleu	masse
Tension	12 V	noir	noir (blanc)	blanc	bleu	marron
	24 V	gris	gris (rouge)	rouge		marron

## SVENSKA



Vid montering av ring 2XX 008 405-XXX tillsammans med lamporna 2XX 008 221-XXX.

Vid användning med värmeavledningsplåt och strömmande luft får lampornas omgivningstemperatur vara högst 70 °C.

Användning av värmeavledningsplåt krävs när omgivningstemperaturen överstiger 50 °C.

### Anvisningar för montering

Montera lampan med Ejot PT-skrivar, 4  
Åtdragningsmoment max 1,8 Nm  
Inskruvningsdjup max 8,5 mm

### Anvisningar för användning

Lampan får endast monteras på personbil/buss/skåpbil.  
Inte lämplig för användning på lastbilar, terrängfordon, trehjulingar och fyrhjulingar!

### Kabelfärger och motsvarande tillordning

Modell		(+) (+)				(-)
		Bakljus	bak-/bromsljus	positionslyset	blå LED-modul	jord
Spänning	12 V	svart	svart (vit)	vit	blå	brun
	24 V	grå	grå (röd)	röd		brun

## NEDERLANDS



Bij montage van de ring 2XX 008 405-XXX in combinatie met de lampen 2XX 008 221-XXX.

De omgevingstemperatuur van de lampen mag bij gebruik met de warmteafleidplaat bij bewogen lucht max. 70° C bedragen.

Het gebruik van de warmte-afleidingsplaat is noodzakelijk bij een omgevingstemperatuur die hoger is dan 50°C.

### Montage-instructies

Bevestiging van de lamp met PT-schroeven 4, bijv. van Ejot Max. draaimoment 1,8 Nm Max. inschroefdiepte 8,5 mm

### Gebruiksaanwijzing

Montage van de lamp **ALLEEN** aan personenauto/bus/caravan. **NIET** geschikt voor vrachtwagens (trucks), terreinwagens, trikes of quads

### Kabelkleuren en toewijzing

		(+)			(-)	
Model		A	A(R)	PO	Blauw	Massa
Spanning	12 V	zwart	zwart (wit)	wit	blauw	bruin
	24 V	grijs	grijs (rood)	rood		bruin

## ESPAÑOL



Al montar el anillo 2XX 008 405-XXX en las luces 2XX 008 221-XXX.

En caso de usar un panel de disipación de calor y con el aire en movimiento, la temperatura ambiente de las luces no debe superar los 70°C.

Será necesario utilizar una chapa de disipación térmica en caso de que la temperatura ambiente sea superior a 50 °C.

### Indicaciones para la fijación

La fijación de las luces se realiza con 4 tornillos PT (por ejemplo del fabricante Ejot) Par de apriete máx. 1,8 Nm, Profundidad de atornillado máx. 8,5 mm

### Indicaciones de uso

Montaje de luces **EXCLUSIVAMENTE** para turismos, autobuses y caravanas. **NO** apto para camiones, vehículos todoterreno, trikes o quads.

### Colores de los cables y su correspondencia

		(+)				(-)
Modelo		Luz trasera	Luz trasera/de freno	Luz de posición	Módulo LED azul	Masa
Tensión	12 V	Negro	Negro (Blanco)	Blanco	Azul	Marrón
	24 V	Gris	Gris (Rojo)	Rojo		Marrón

## ITALIANO



Per il montaggio dell'anello  
2XX 008 405-XXX  
insieme alle luci  
2XX 008 221-XXX.

Utilizzando il deflettore in lamiera con aria in movimento, la temperatura ambiente dei fari non deve superare 70° C.

L'utilizzo del deflettore in lamiera è necessario in caso di temperatura ambiente superiore ai 50°C.

## Nota per il fissaggio

Fissaggio del fanale mediante viti PT 4 come quelle della ditta Ejot  
Coppia di serraggio max. 1,8Nm  
Profondità di avvitamento max.

## Nota per l'uso

Montaggio a sbalzo del fanale **SOLO** su autoveicoli / bus / caravan  
**NON ADATTO** per autocarri (Truck), veicoli fuoristrada, Trike o Quad

## Colore dei cavi e relativa assegnazione

Modello		(+)				(-)
		Luce di posizione posteriore	Luce di posizione posteriore (Luce stop)	Luce di posizione	Modulo LED blu	Massa
Tensione	12 V	nero	nero (bianco)	bianco	blu	marrone
	24 V	grigio	grigio (rosso)	rosso		Marrón

## SUOMI



Renkaan  
2XX 008 405-XXX  
asennuksessa  
yhdessä valaisimien  
2XX 008 221-XXX  
kanssa.

Valojen ympäristössä virtaavan ilman lämpötila ei saa olla yli 70°C käytettäessä jäähdytyslevyä.

Lämmön poisjohtolevyn käyttö on tarpeellista ympäristönlämpötilan ollessa > 50°C.

## Kiinnitysohje

Valo kiinnitetään PT-ruuveilla 4, esim. firman Ejot ruuveilla  
Vääntömomentti maks. 1,8 Nm  
Kierteitysryvyys maks. 8,5 mm

## Käyttöohje

Valon saa asentaa vain henkilö-/linja-autoihin/asuntovaunuihin. **EI** kuorma-autoihin (rekat), maastoautoihin, kolmipyöriin eikä maastonelikkoihin.

## Johtojen värit ja paikat

Malli		(+)				(-)
		S	S (B)	PO	sininen	maajohto
Jännite	12 V	musta	musta (valkoinen)	valkoinen	sininen	ruskea
	24 V	harmaa	harmaa (punainen)	punainen		ruskea

130.com.ua

130.com.ua

