



PHONES

(044) 360-7-130
(050) 336-0-130
(063) 788-0-130
(067) 233-0-130
(068) 282-0-130

130 Internet store of autogoods

COM.UA



ICQ
294-0-130
597-0-130

SKYPE
km-130

CAR RECEIVERS — Receivers • Media receivers and stations • Native receivers • CD/DVD changers • FM-modulators/USB adapters • Flash memory • Facia plates and adapters • Antennas • Accessories |
CAR AUDIO — Car audio speakers • Amplifiers • Subwoofers • Processors • Crossovers • Headphones • Accessories | TRIP COMPUTERS — Universal computers • Model computers • Accessories |
GPS NAVIGATORS — Portable GPS • Built-in GPS • GPS modules • GPS trackers • Antennas for GPS navigators • Accessories | VIDEO — DVR • TV sets and monitors • Car TV tuners • Cameras • Videomodules
• Transcoders • Car TV antennas • Accessories | SECURITY SYSTEMS — Car alarms • Bike alarms • Mechanical blockers • Immobilizers • Sensors • Accessories | OPTIC AND LIGHT — Xenon • Bixenon • Lamps
• LED • Stroboscopes • Optic and Headlights • Washers • Light, rain sensors • Accessories | PARKTRONICS AND MIRRORS — Rear parktronic • Front parktronic • Combined parktronic • Rear-view mirrors
• Accessories | HEATING AND COOLING — Seat heaters • Mirrors heaters • Screen-wipers heaters • Engine heaters • Auto-refrigerators • Air conditioning units • Accessories | TUNING — Vibro-isolation
• Noise-isolation • Tint films • Accessories | ACCESSORIES — Radar-detectors • Handsfree, Bluetooth • Windowlifters • Compressors • Beeps, loudspeakers • Measuring instruments • Cleaners • Carsits
• Miscellaneous | MOUNTING — Installation kits • Upholstery • Grilles • Tubes • Cable and wire • Tools • Miscellaneous | POWER — Batteries • Converters • Start-charging equipment • Capacitors
• Accessories | MARINE AUDIO AND ELECTRONICS — Marine receivers • Marine audio speakers • Marine subwoofers • Marine amplifiers • Accessories | CAR CARE PRODUCTS — Additives • Washer fluid •
Care accessories • Car polish • Flavors • Adhesives and sealants | LIQUID AND OIL — Motor oil • Transmission oil • Brake fluid • Antifreeze • Technical lubricant



In store "130" you can find and buy almost all necessary goods for your auto in Kyiv and other cities, delivery by ground and postal services. Our experienced consultants will provide you with exhaustive information and help you to chose the very particular thing. We are waiting for you at the address

<http://130.com.ua>

Integration 130 VRS



2-way kit

- Butyl surround
- Promoting long life**
- Shallow mounting (1 15/16"/48.5mm)
- Easy integration in the most exiguous spaces**
- Polyglass cone
- Neutral sound without coloration**



- Air core inductors with a low serial resistance
- Insensitive to parasites, better sensitivity**
- Adjustable tweeter level
- Tweeter level setting according to the positioning**
- Polypropylene/Aluminum capacitor
- Natural reproduction of high frequencies**

- Zamak basket
- Strong rigid chassis, non magnetic, non resonant**
- 1 1/4" (32mm) voice coil on Kapton® former
- High power handling**
- N38 neodymium magnet
- High magnetic field for a high sensitivity**
- Voice coil cooling system
- Optimized reliability, no dynamic compression**

- Aluminum/magnesium inverted dome TNB tweeter
- Smooth and detailed treble, large and precise sound stage**
- Dual push-pull neodymium magnet
- Excellent linearity of the tweeter**
- Voice coil on aluminum former
- High dissipation characteristics**

ADVANTAGES

- Easy installation for all kind of vehicles (shallow mounting: 1 15/16" / 48.5mm)
- Hi-Fi sound for an optimized realism
- Large and precise sound stage
- The essentials of Focal sound

TECHNICAL CHARACTERISTICS

Woofer: 5" (130mm)
Voice-coil: 1 1/4" (32mm)
Neodymium magnet: N38
TNB tweeter: 1 3/4" (45mm)
Aluminum/magnesium inverted dome tweeter

2-way component crossover: 12/18dB/oct. (4kHz)
Adjustable tweeter level: (0, -3, -6dB)
Max. power: 100W
Nom. power: 50W rms

Sensitivity (2.83V/1m): 91dB
Frequency response: 80Hz – 28kHz
Accessories: supplied grilles

Integration 130 VRS



- Zamak chassis
- Polyglass cone, Butyl surround
- Neodymium magnet

SPECIFICATIONS

Nominal power	50W	
Maximum power	100W	
Sensitivity	91dB	
Cone	Polyglass	
Surround	Butyl	
Nom. impedance	4 Ohms	
DC resistance	2.8 Ohms	
VC diameter	32mm	1 1/4"
VC height	10mm	0 3/8"
Former	Kapton®	
Layers	2	
Wire	Copper	
Inductance	0.3mH	
Xmax	3mm	0 1/8"
Magnet d x h	-	
Magnet weight	-	
Flux density	1T	
Gap height	4mm	
Net weight	550g	1.21lb

FREQUENCY RESPONSE / IMPEDANCE

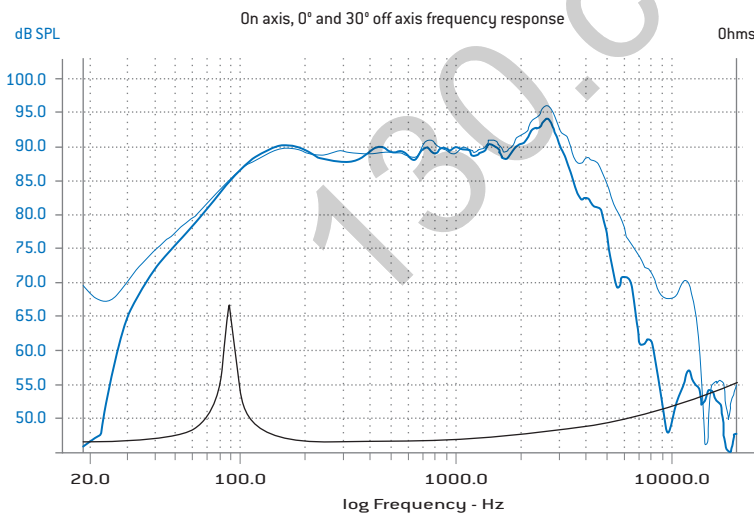

PARAMETERS

Fs	93,15Hz
Vas	3.04 l
Qts	0.657
Qes	0.7
Qms	10.7
Re	2.9 Ohms
Sd	95.03cm ²
Cas	2.16 E-8m ⁵ /N
Mas	135.09kg/m ⁴
Ras	7389.04 Ohms.ac
Cms	2.39 E-04m/N
Mms	12.2g
Rms	0.667kg/s
Ces	427.15mF
Les	6.83mH
Res	43.80 Ohms
BI	5.34N/A
SPL	91.68 dB/W/m

MECHANICAL DRAWING

Unit: mm

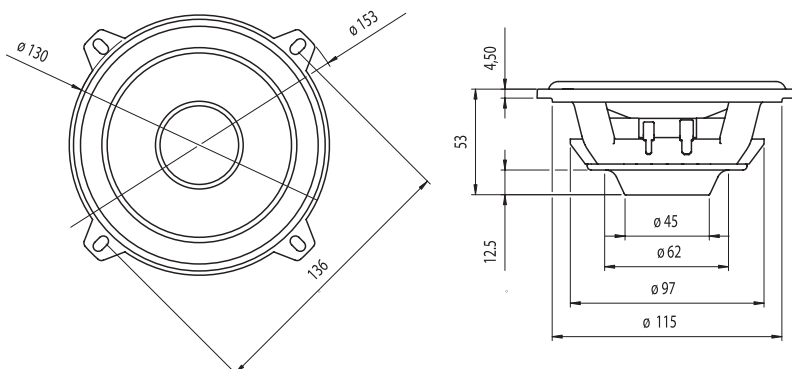



Tweeter TNB



- 20mm push-pull Neodymium magnet
- 20mm voice-coil with aluminum former
- Optional accessories for easy mounting
- Aluminum/Magnesium inverted dome

SPECIFICATIONS

Nominal power	15W	
Maximum power	100W	
Sensitivity	91dB	
Cone	Aluminum/Magnesium	
Surround	-	
Nom. impedance	8 Ohm	
DC resistance	6 Ohm	
VC diameter	20.5mm	4.5 in
VC height	1.5mm	1/16 in
Former	Aluminum	
Layers	2	
Wire	Aluminum	
Inductance	0.06mH	
Xmax	-	
Magnet d x h	20 x 2mm	13/16x1/16 in
Magnet weight	-	2.2lb
Flux density	1.6 T	
Gap height	2mm	1/16 in
Net weight	85g	0.18 lb

SUGGESTED APPLICATION

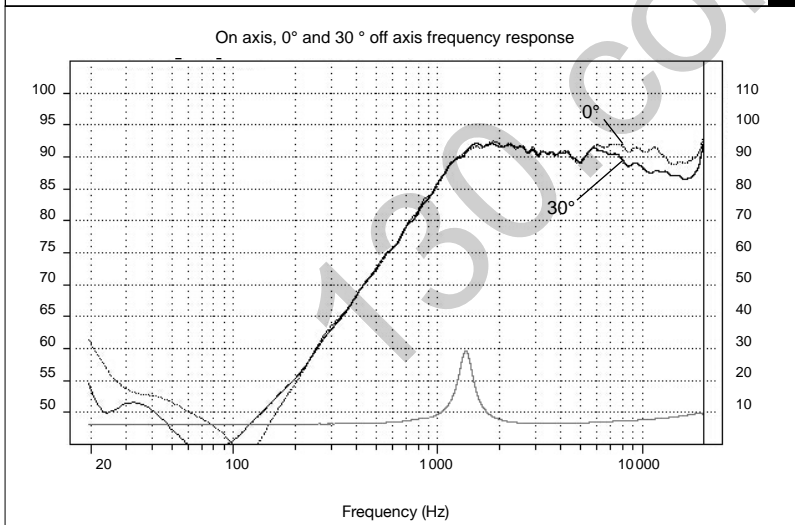

PARAMETERS

Fs	1280Hz	
Re	6 Ohm	
Res	34 Ohm	

MECHANICAL DRAWING

