



PHONES

(044) 360-7-130
(050) 336-0-130
(063) 788-0-130
(067) 233-0-130
(068) 282-0-130

130
COM.UA

Internet store of
autogoods



ICQ
294-0-130
597-0-130

SKYPE
km-130

CAR RECEIVERS — Receivers • Media receivers and stations • Native receivers • CD/DVD changers • FM-modulators/USB adapters • Flash memory • Facia plates and adapters • Antennas • Accessories |
CAR AUDIO — Car audio speakers • Amplifiers • Subwoofers • Processors • Crossovers • Headphones • Accessories | TRIP COMPUTERS — Universal computers • Model computers • Accessories |
GPS NAVIGATORS — Portable GPS • Built-in GPS • GPS modules • GPS trackers • Antennas for GPS navigators • Accessories | VIDEO — DVR • TV sets and monitors • Car TV tuners • Cameras • Videomodules
• Transcoders • Car TV antennas • Accessories | SECURITY SYSTEMS — Car alarms • Bike alarms • Mechanical blockers • Immobilizers • Sensors • Accessories | OPTIC AND LIGHT — Xenon • Bixenon • Lamps
• LED • Stroboscopes • Optic and Headlights • Washers • Light, rain sensors • Accessories | PARKTRONICS AND MIRRORS — Rear parktronic • Front parktronic • Combined parktronic • Rear-view mirrors
• Accessories | HEATING AND COOLING — Seat heaters • Mirrors heaters • Screen-wipers heaters • Engine heaters • Auto-refrigerators • Air conditioning units • Accessories | TUNING — Vibro-isolation
• Noise-isolation • Tint films • Accessories | ACCESSORIES — Radar-detectors • Handsfree, Bluetooth • Windowlifters • Compressors • Beeps, loudspeakers • Measuring instruments • Cleaners • Carbits
• Miscellaneous | MOUNTING — Installation kits • Upholstery • Grilles • Tubes • Cable and wire • Tools • Miscellaneous | POWER — Batteries • Converters • Start-charging equipment • Capacitors
• Accessories | MARINE AUDIO AND ELECTRONICS — Marine receivers • Marine audio speakers • Marine subwoofers • Marine amplifiers • Accessories | CAR CARE PRODUCTS — Additives • Washer fluid •
Care accessories • Car polish • Flavors • Adhesives and sealants | LIQUID AND OIL — Motor oil • Transmission oil • Brake fluid • Antifreeze • Technical lubricant



In store "130" you can find and buy almost all necessary goods for your auto in Kyiv and other cities, delivery by ground and postal services. Our experienced consultants will provide you with exhaustive information and help you to chose the very particular thing. We are waiting for you at the address

<http://130.com.ua>

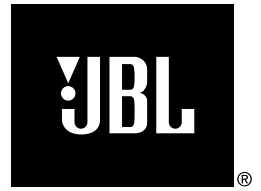

jbl® **MS-8**

System integration digital processor



USER GUIDE

Introduction	3
Important! Read Before You Begin	4
Box Contents	4
Applications	4
Connections	5
Power	5
Audio Inputs	7
Audio Outputs	11
Display	15
Microphone	15
Update	16
Installation	17
Choosing a Location for the Main Unit	17
Mounting the Main Unit	18
Choosing a Location for the Display Unit	18
Installing the Display Unit	19
Mounting the Remote Control	22
Using the Remote Control	23
Calibration/Setup	24
Language Selection	25
Input Setup	25
Output Setup	26
Acoustic Calibration	32
Using the MS-8	35
Volume Up and Volume Down Buttons	35
Main Menu	35
Input Selection Menu	36
Audio Controls Menu	36
Favorites Menu	39
System Settings Menu	40
Resetting the Microprocessor	41
Troubleshooting	42
Specifications	47

Thank you for your purchase of the JBL® MS-8 System Integration Digital Processor. We have designed the MS-8 to make successful installation and setup easy and to provide you with years of enjoyable and great sound.

We have also designed the MS-8 and this owner's manual to make do-it-yourself installation an option for those DIYers who have some experience in mechanical and electrical procedures and who have access to the simple tools required for minor disassembly of automotive interior panels. We have designed the MS-8 to minimize the disassembly required and to make electrical connections to any existing system as simple as possible.

Please read this manual carefully before attempting installation. If you do not have the necessary tools or experience, do not attempt the installation yourself. Instead, please ask your authorized JBL car audio dealer about professional installation or visit www.JBL.com to find the nearest professional.

This manual explains how to install, set up and use your MS-8 in a general sense but will not indicate the specific wiring codes, connections and locations for your particular vehicle. There are many online resources that provide wiring codes and diagrams for vehicles. JBL's technicians or Web pages may also be able to help.

This manual does not explain why the MS-8 works. If you have technical questions that this manual does not answer, or if you want to do some additional reading to understand the technology that the MS-8 contains, please visit us on the Internet at www.JBL.com.

Thanks again for your purchase, and we sincerely hope that JBL's MS-8 will provide you with years of happy listening.

Warning

Playing loud music in an automobile can hinder your ability to hear traffic and can permanently damage your hearing. We recommend listening at low or moderate levels while driving your car. JBL accepts no liability for hearing loss, bodily injury or property damage resulting from the use or misuse of this product.

Replacing the Fuse

If you must replace the MS-8 s fuse, use only the same type and rating as that of the original. Do not substitute another kind.

BOX CONTENTS

- (1) MS-8 main unit
- (1) MS-8 display unit and base
- (1) Hi Level input wiring harness (gray and white insulation)
- (1) Speaker-output wiring harness (clear insulation)
- (1) 6m (19.7 ft), 2.5mm (1") three-conductor cable for display unit
- (1) Wireless remote control (battery installed)
- (1) Remote-control installation tray
- (1) Remote-control trim ring
- (1) Binaural microphone headset
- (1) Calibration and setup CD (includes instruction manual and quick-start guide)
- (1) Quick-start guide
- (4) 4x20 screws
- (3) 3.5x20 screws
- (2) 3x20 screws
- (2) Hexagonal (hex) wrenches
- (2) Adhesive pads
- (4) Alcohol prep pads

APPLICATIONS

The MS-8 s extensive crossover capabilities allow you to configure its eight channels in a number of different ways, depending on the type and number of speakers in your vehicle s audio system. JBL recommends that you carefully plan your system and its connections before beginning installation.

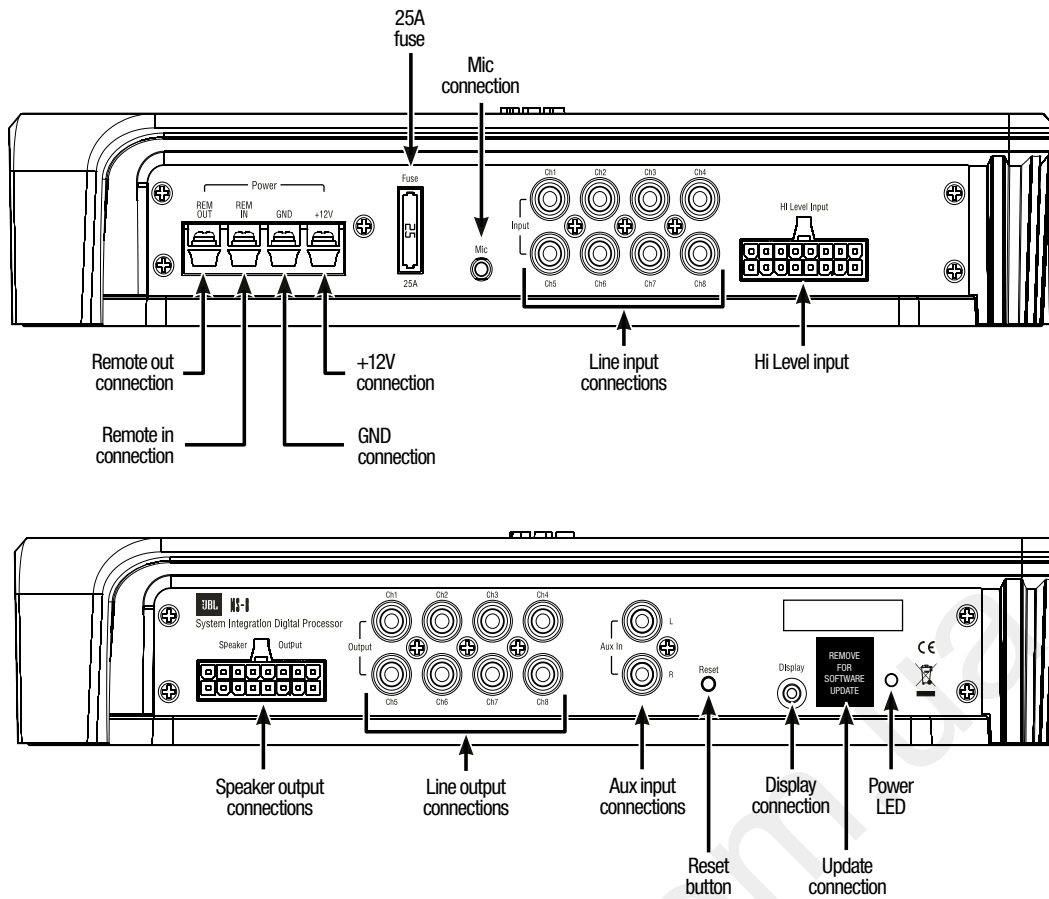

POWER

IMPORTANT: Perform the power connections in the following order.

1. **Gnd:** Connect this terminal to a paint-free location on the vehicle chassis.

IMPORTANT: Use at least 12-gauge wire for this connection.

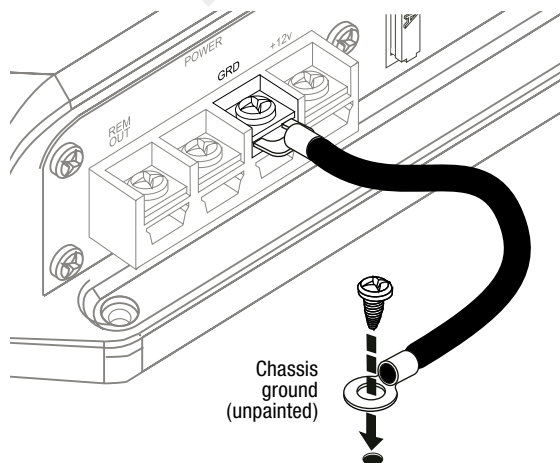

2. **+12V:** Connect this terminal to the vehicle battery's positive (+) terminal. Insert a 25A fuse in series on the +12V wire no further than 18 inches (46cm) from the battery terminal.

IMPORTANT: Use at least 12-gauge wire for this connection.

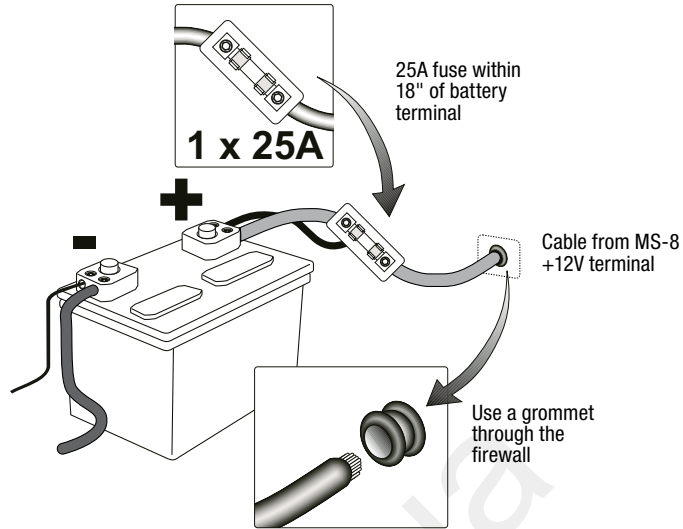

3. **Rem Out:** Connect this terminal to the remote turn-on terminals of all amplifiers in the system. The output is +12V DC, 1A.

IMPORTANT: The MS-8 MUST control the turn-on signal of all the other amplifiers that follow the MS-8 in the signal path.

If your system includes a factory-installed outboard amplifier, the turn-on signal may be available at the amplifier. If your factory amplifier has a turn-on wire, cut it and connect the head-unit side of the wire to the MS-8's Rem In terminal and the amplifier side of the wire to the MS-8's Rem Out terminal.

This arrangement will allow the factory stereo to turn the MS-8 on whenever the stereo is turned on and will allow the MS-8 to turn the factory amplifier on and off. It will also help to eliminate audible clicks and pops when the system turns on and off.

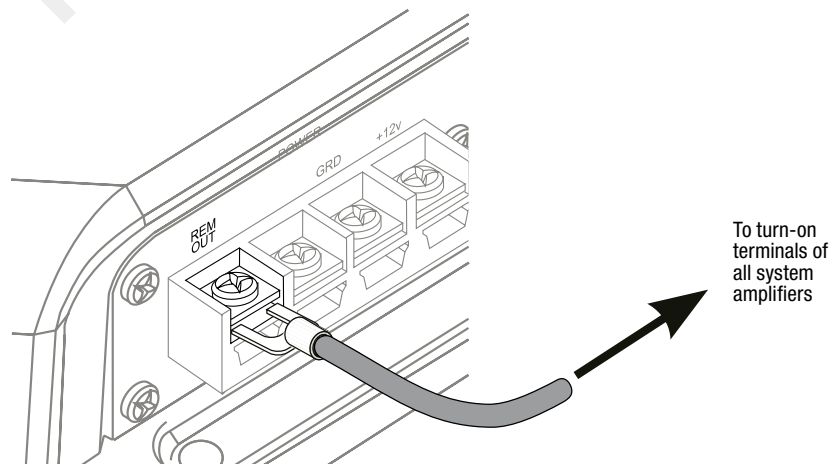

Rem In: Connect this terminal to the remote turn-on output of the system's source unit, if the source unit has a remote turn-on output. Alternately, you can connect this terminal to the vehicle's accessory (ACC) power circuit. Any voltage over +4V DC at this terminal will trigger the MS-8 to turn on.

NOTE: See Step 3 for more details about connecting the Rem In terminal to a factory-installed stereo system.

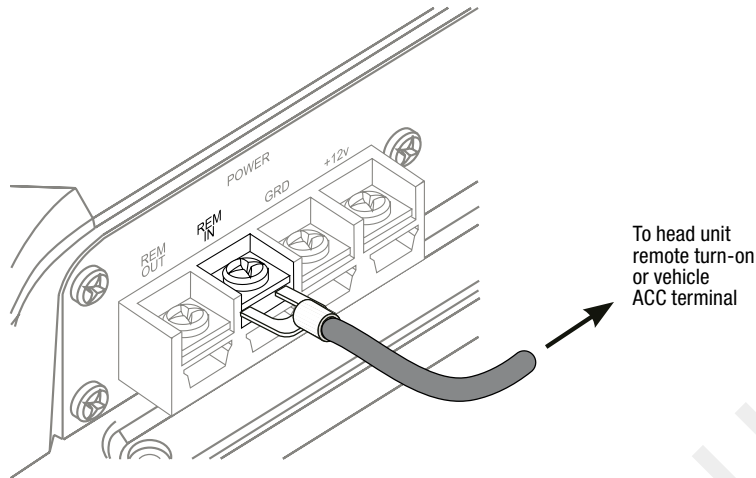

AUDIO INPUTS

Many factory-installed systems include on-board equalization and crossovers that make simple connection of aftermarket products difficult. The MS-8 includes the signal-summing circuitry, signal-conditioning EQ and time-correction processing that are necessary to reconstruct a flat, full-range, two-channel signal when you use the MS-8 with factory-installed equipment.

Aftermarket head units with line outputs provide a flat, full-range, two-channel signal on their front line outputs, so you need to connect only those channels to the MS-8.

Connecting an aftermarket head unit

If you're using the MS-8 with an aftermarket head unit that has RCA-type outputs, connect the head unit's front left and front right outputs to the MS-8's line inputs 1 and 2 only. Do NOT connect any other head-unit output signals to the MS-8's line inputs 3 – 8. During the calibration/setup process, the MS-8 will normalize the input signals and derive as many output signals as your speaker system requires.

IMPORTANT: Do not connect the head unit directly to any amplifiers, including a subwoofer amplifier. The MS-8's signal processing takes nearly 8ms, so any signals connected directly to a head-unit will be ahead of the signals leaving the MS-8 by about 8ms. This difference will cause them to be out of sync with the signals that pass through the MS-8. **The MS-8 must generate all the signals that are sent to all of the system's speakers!**

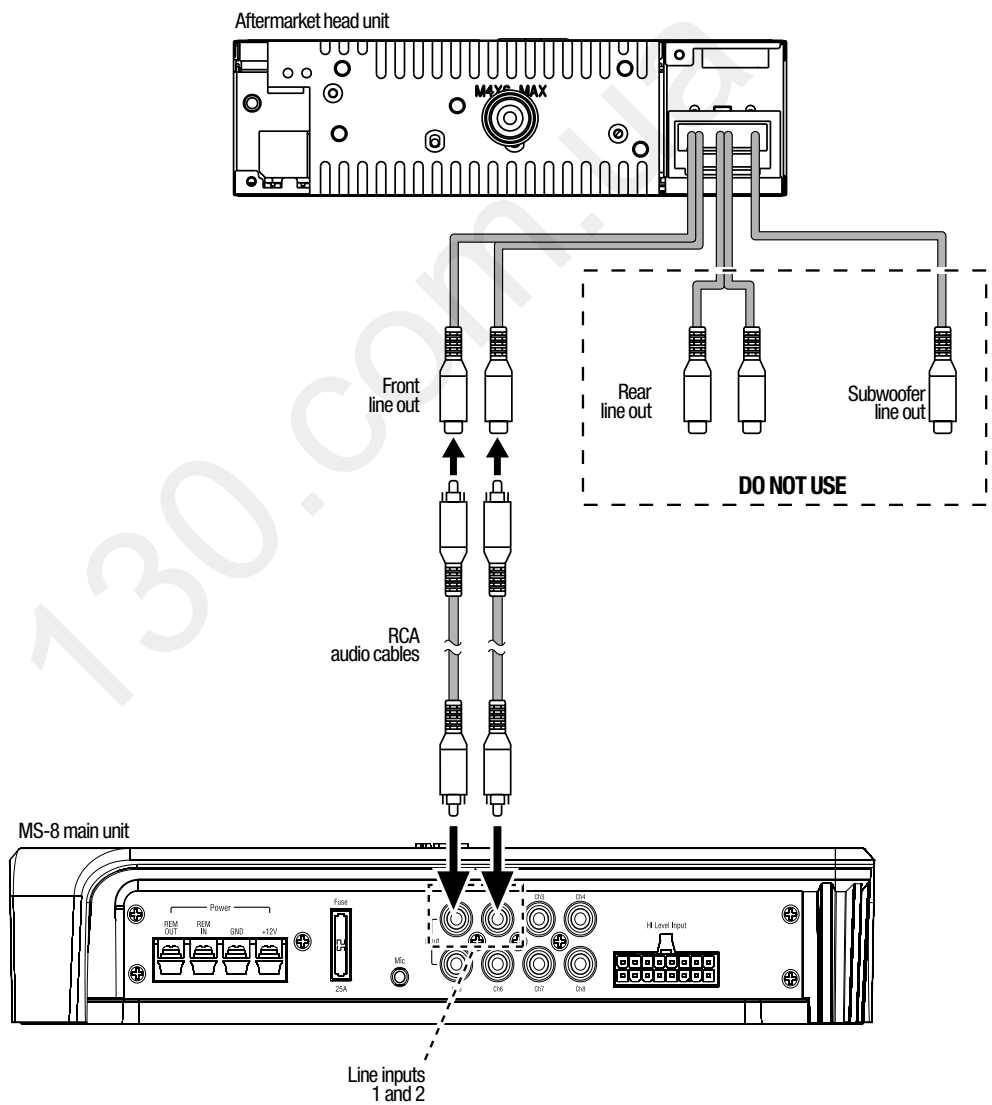

Connecting a factory radio/head unit

If you will be connecting the MS-8 to a factory-installed stereo or a factory-installed amplifier (often located in the vehicle's trunk), connect each of your factory front-speaker and subwoofer outputs to one of the MS-8's Hi Level inputs. Be sure to connect the outputs for all speakers that are part of the vehicle's front left and front right speakers.

You can connect the factory front speaker outputs to any MS-8 Hi Level inputs, *but factory stereo or amplifier subwoofer outputs MUST be connected ONLY to the MS-8's channel 7 and/or 8 inputs.* During the calibration/setup process, the MS-8 will normalize the input signals and derive as many output signals as your speaker system requires.

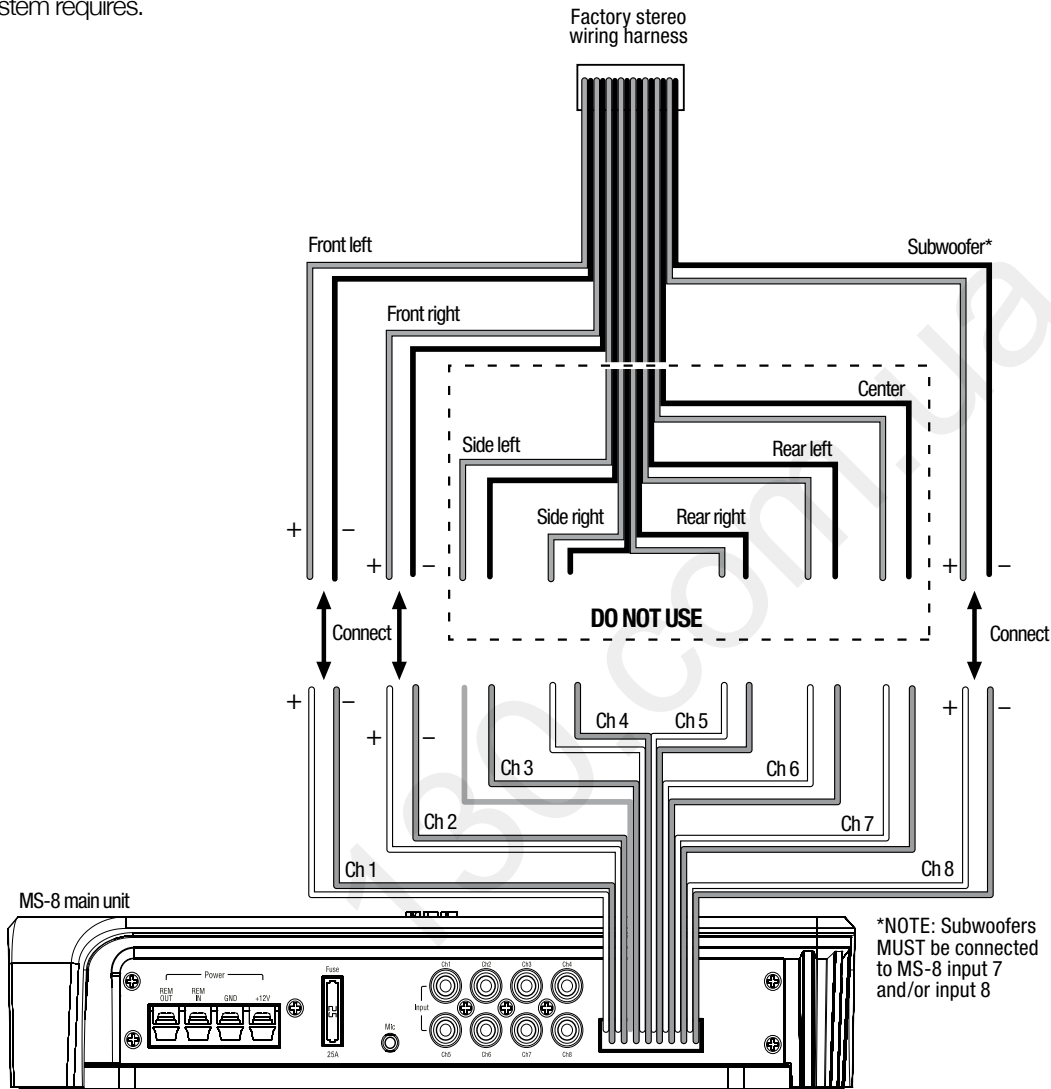

NOTE: The above illustration shows only a general connection example and does not represent any particular vehicle audio system.

Insert the included Hi Level input wiring harness into the MS-8's Hi-Level-input connector until it locks into place.

IMPORTANT: The MS-8's Hi Level input wiring harness has gray and white wires. Each channel has a white (positive or +) wire and a gray (negative or -) wire. Each wire is labeled with its channel number and polarity, and is pre-stripped for easy connection to your factory radio's speaker outputs. **Make sure that the (+) and (-) wires do not touch each other. Touching wires can cause a short circuit that can damage the MS-8 or your head unit.**

To ensure proper polarity, connect each factory-radio positive (+) terminal to the respective + terminal on the MS-8. Connect the negative (-) terminals in a similar way.

Aux input: If you will be using a portable music player or CD player as an auxiliary audio-source unit, connect its line or headphone output to the MS-8's Aux input using a cable that terminates in stereo RCA audio connections. You can switch between the MS-8's Head Unit inputs and Aux input in the MS-8's Input Selection menu. See *Main Menu*, on page 35.

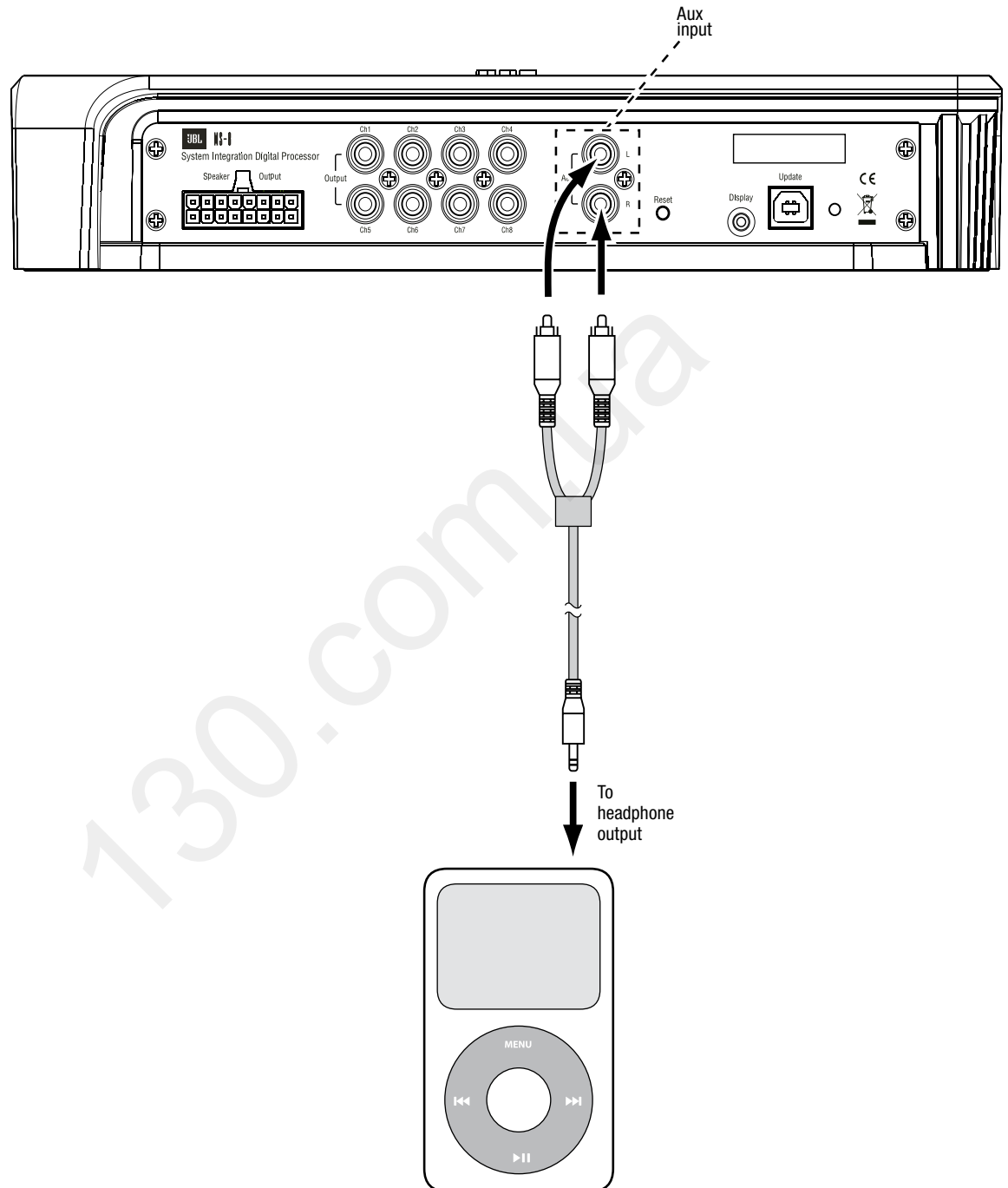

AUDIO OUTPUTS

Configurations

You can configure the MS-8's eight outputs in a variety of ways, depending on the speakers that are installed in your vehicle. You can configure the MS-8 for a system with one-way (full-range), two-way or three-way front speakers, a one-way or two-way center speaker, side speakers, rear speakers and one or two subwoofers. Remember, however, that the total number of available channels is eight, so any combination of front, center, side, rear and subwoofer channels cannot total more than eight. For example, if you are allocating six channels for a pair of tri-amped, three-way front speakers, there will be only two remaining channels, which will not accommodate a pair of rear speakers and a subwoofer.

If your system will include more than eight channels, use additional separate amplifiers (connected to the MS-8's line outputs) for the additional channels. For example, if you want to build a 7.1-channel system that includes bi-amped or tri-amped front speakers, use the MS-8 to generate the 7.1-channel outputs (seven full-range and one subwoofer). Connect the MS-8's front line outputs to the inputs of an additional crossover (or amplifier containing an additional crossover) that will provide the separate channels required to drive the front midbass, midrange and/or tweeters separately.

Use the Configuration Chart below to record which of your system's speakers you have connected to which of the MS-8's outputs. Keeping this record will simplify channel assignment during the setup procedure. See *Main Menu*, on page 35.

Output #	Channel / Speaker Connected	Output Connector Used
1		<input type="radio"/> RCA <input type="radio"/> SPEAKER
2		<input type="radio"/> RCA <input type="radio"/> SPEAKER
3		<input type="radio"/> RCA <input type="radio"/> SPEAKER
4		<input type="radio"/> RCA <input type="radio"/> SPEAKER
5		<input type="radio"/> RCA <input type="radio"/> SPEAKER
6		<input type="radio"/> RCA <input type="radio"/> SPEAKER
7		<input type="radio"/> RCA <input type="radio"/> SPEAKER
8		<input type="radio"/> RCA <input type="radio"/> SPEAKER

Speaker Outputs

If you'll use the MS-8's built-in power amplifiers to drive your system's speakers, connect the speakers to the MS-8's speaker outputs. Insert the included speaker-output wiring harness into the MS-8's speaker output until it locks into place. See *Main Menu*, on page 35.

IMPORTANT: The MS-8's speaker-output wiring harness's wires have clear insulation. Each channel has a copper (positive or +) conductor and a silver (negative or -) conductor. We have labeled each conductor with its channel number and polarity, and pre-stripped it for easy connection to your system's speakers. **Make sure that the (+) and (-) wires do not touch each other. Touching wires can cause a short circuit that can damage the MS-8.**

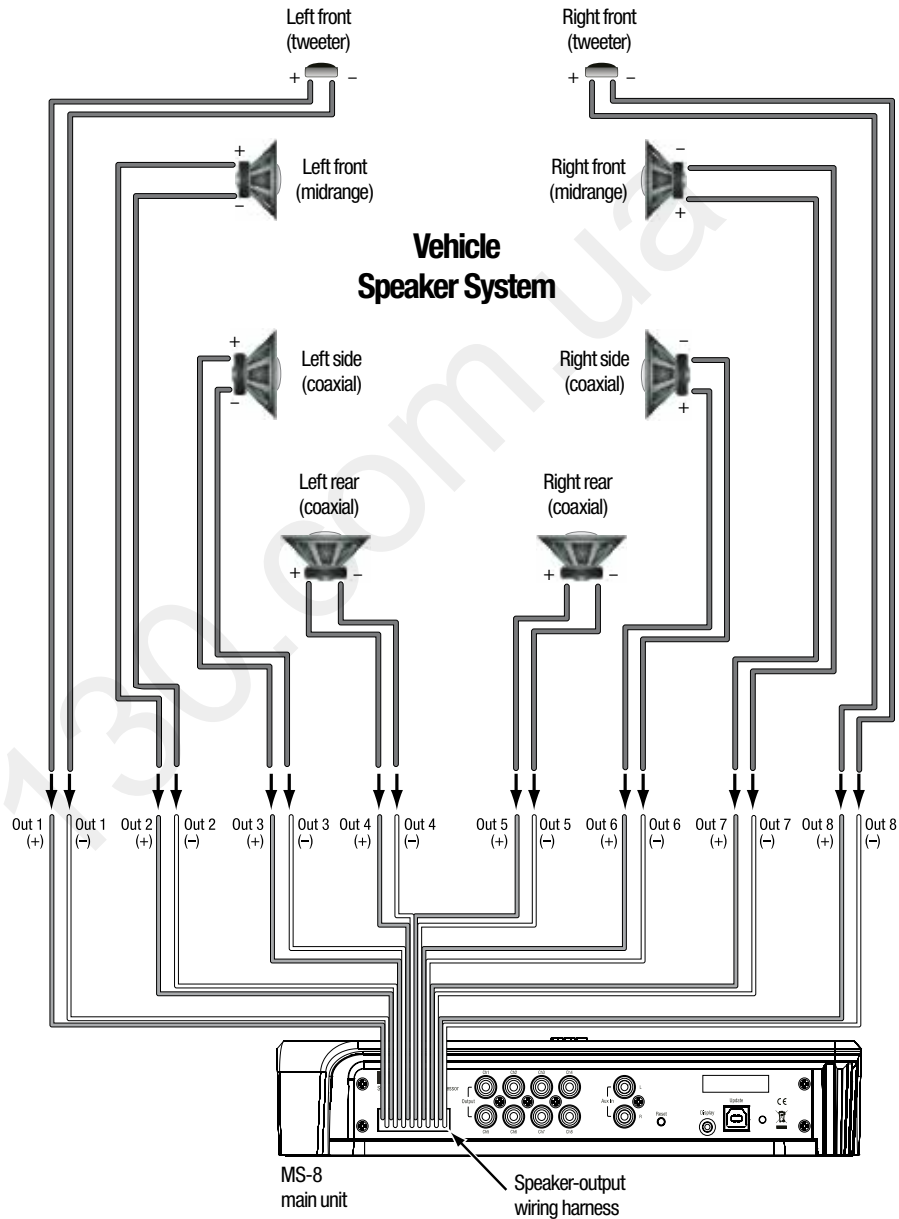

To ensure proper polarity, connect each MS-8 positive (+) terminal to the respective + terminal on the speaker. Connect the negative (-) terminals in a similar way.

NOTE: You can power some of the system's speakers by the MS-8's amplifiers and some by outboard amplifiers, but you should use only one connection type per output. For example, output channel 1 may use the MS-8's amplifier OR an outboard amplifier, but not both. Be sure to use the chart above to note which speakers are connected to which MS-8 channels.

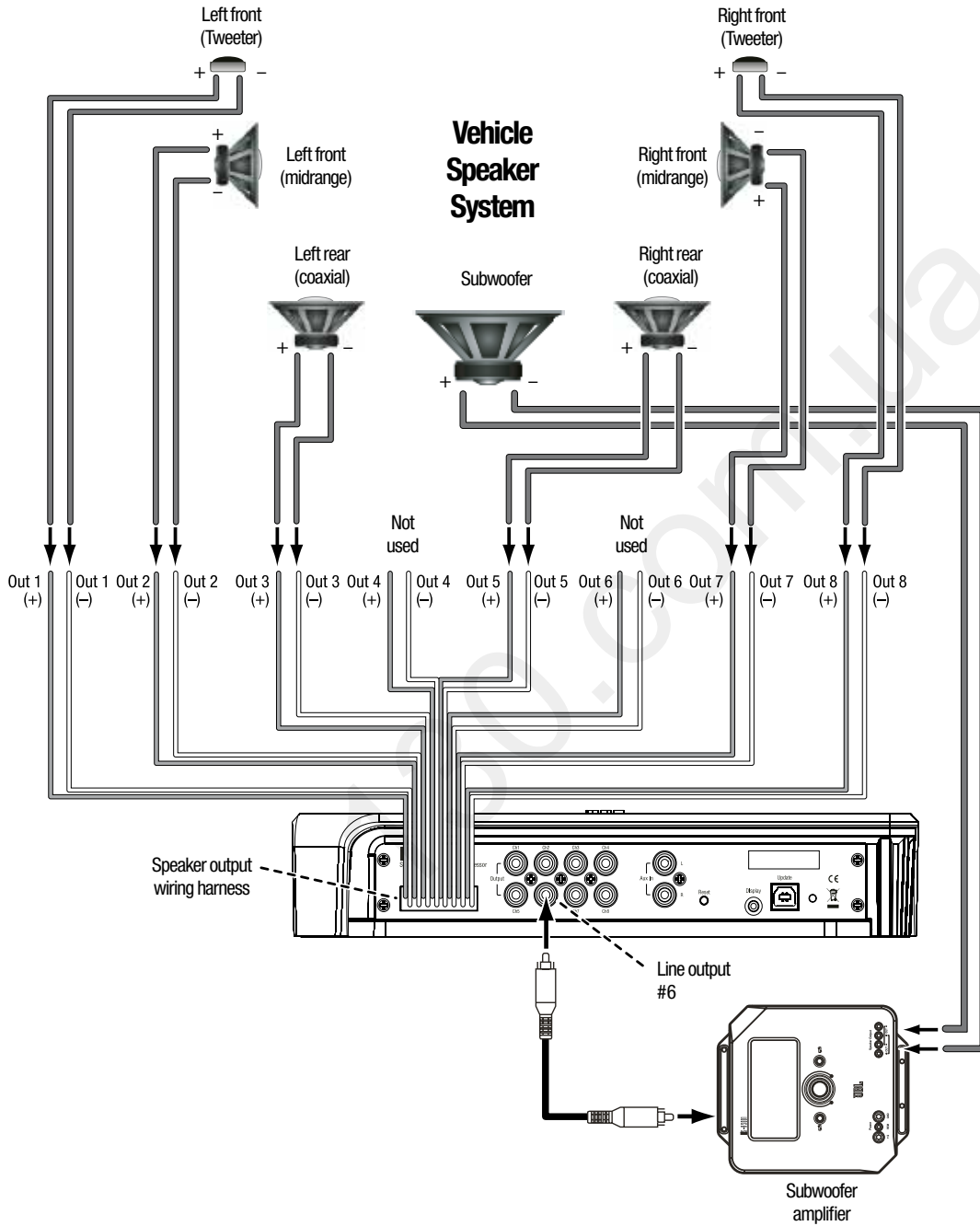

Line Outputs

If you'll be using additional outboard power amplifiers to drive your system's speakers, connect their inputs to the MS-8's line-output connectors. You can power some of the system's speakers by the MS-8's amplifiers and some by outboard amplifiers, but you should use only one connection type per output. For example, Output Channel 1 may use the MS-8's amplifier OR an outboard amplifier, but not both. Be sure to use the chart above to note which speakers you have connected to which of the MS-8's channels.

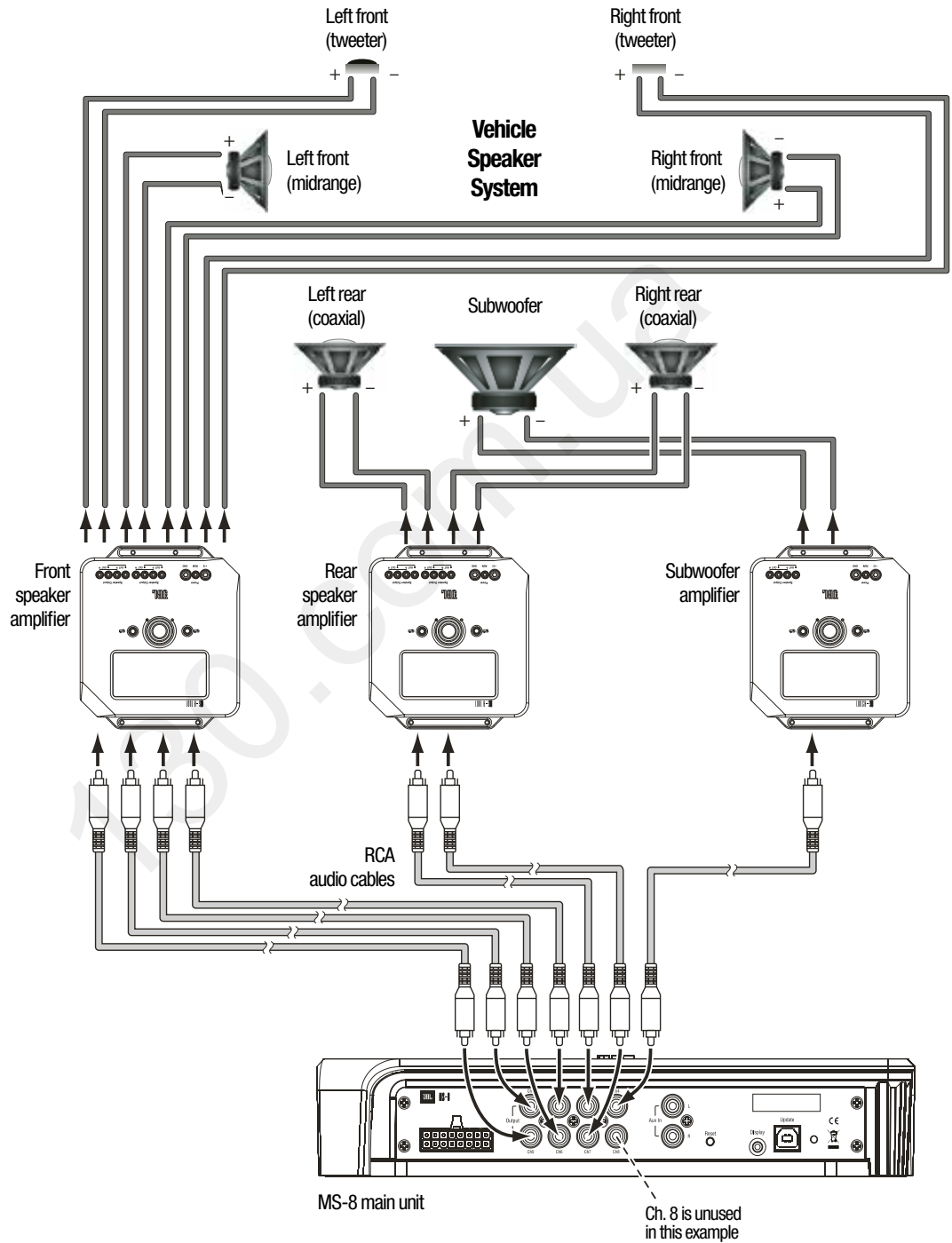

DISPLAY

Use the included 6m (19.7 ft) cable to connect the display unit to the MS-8 s main unit s display connection. Insert the cable s straight connector into the main unit and the right-angle connector into the display.

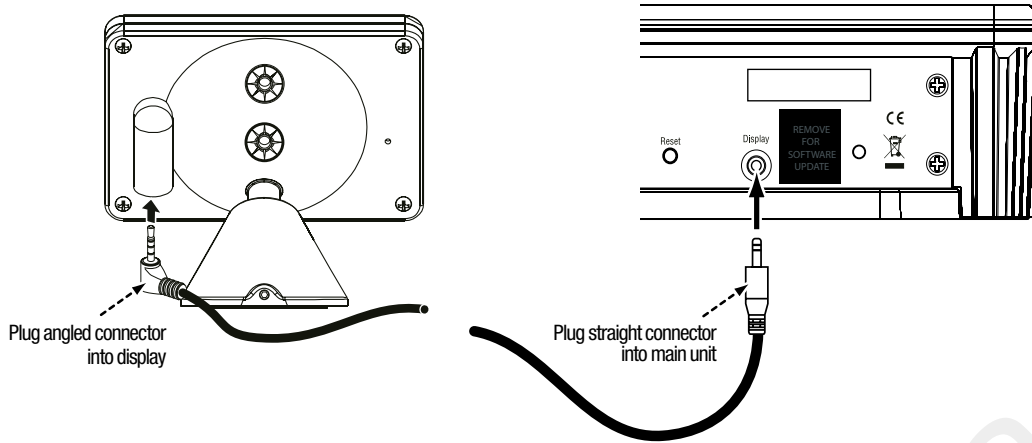

NOTE: The display unit must be connected during setup but may be disconnected after setup and after you ve made any additional adjustments in the Audio Controls menu (see *Audio Controls Menu*, on page 36). If the display unit is disconnected after setup and final adjustment, you will not be able to make any additional MS-8 adjustments, and the remote control will not function. See *Main Menu*, on page 35.

MICROPHONE

The included binaural microphone headset must be connected to the MS-8 s Mic connection during the calibration/setup process. Once setup is complete, unplug the microphone headset and store it in a safe place.

IMPORTANT: Do not use any other microphone with the MS-8.

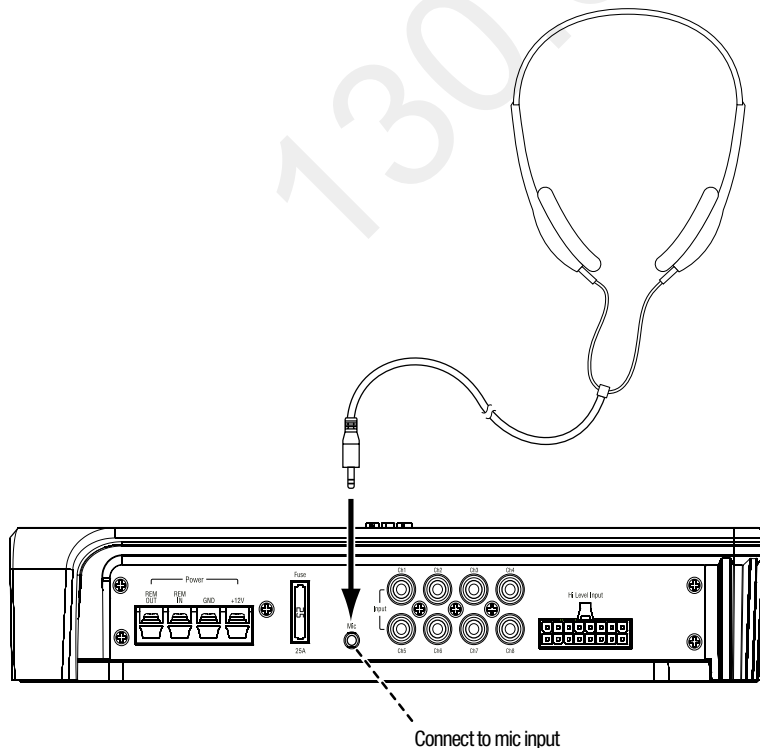

UPDATE

Use the Update port only for firmware upgrades. We have covered it with a sticker that you should leave in place until you are ready to install a firmware upgrade that you will download from www.JBL.com.



REMOVE
FOR
SOFTWARE
UPDATE

After downloading a firmware upgrade into your PC, remove the sticker and connect the Update port to a USB port on your PC. Follow the directions that accompany the upgraded firmware to upload the new firmware from your PC to the MS-8.

130.com.ca

Installation warning and tips

- Always wear protective eyewear when using tools.
- Before beginning the installation, disconnect the negative (-) lead from the vehicle's battery.
- Check clearances on both sides of a potential mounting surface before you drill any holes or install any screws. Remember that the screws can extend behind the surface.
- At the installation sites, locate and make a note of any fuel lines, hydraulic brake lines, vacuum lines and electrical wiring. Use extreme caution when cutting or drilling in and around these areas.
- Before drilling or cutting holes, use a utility knife to remove unwanted fabric or vinyl to keep the material from snagging in a drill bit.
- When routing cables, keep input-signal cables away from power cables and speaker wires.
- When making connections, make certain that they are secure and properly insulated.

CHOOSING A LOCATION FOR THE MAIN UNIT

Cables and wiring

- Before mounting the main unit, plan your system's wiring to ensure that all the necessary cables and wires will reach the mounting location.
- Leave enough room around the unit to accommodate all of the connecting cables and wiring harnesses.
- If you're planning on permanently mounting the display unit in the vehicle, be sure to mount the main unit close enough to the display unit's intended mounting location so the supplied 6m (19.7 ft) cable will reach between them.

Cooling requirements

- Make sure that the mounting location will supply enough air for the unit to cool itself.
- Do NOT mount the main unit in the engine compartment.

Suitable mounting locations

- Under a seat (provided that the unit and connecting cables don't interfere with the seat-adjustment mechanism).
- In the trunk.
- In any other location that provides enough cooling air.

MOUNTING THE MAIN UNIT

Using the main unit as a template, mark the locations of the mounting holes on the mounting surface; drill pilot holes; and attach the unit to the mounting surface with the supplied screws.

- Mount the unit securely.
- Mount the unit so that it remains dry.
- Mount the unit so that neither it nor any of its connections are damaged by the feet of backseat passengers or by cargo shifting in the trunk.

NOTE: You may find it easier to attach the MS-8's main unit to the mounting surface after you've made all connections to it (but before you reconnect the vehicle's battery ground cable).

CHOOSING A LOCATION FOR THE DISPLAY UNIT

IMPORTANT: Install the MS-8's display unit according to these instructions and any relevant regulations. No part of this system should obstruct the driver's view of the road, the vehicle controls or the information displays necessary for safely operating the vehicle. Position the display unit to eliminate glare and reflections and to be as close as possible to the driver's normal line of sight.

Mounting the MS-8's display unit on the windshield, or top of the dashboard between the driver and the windshield, may violate the law in your municipality. Be sure to consult local laws before mounting the display unit.

You can mount the display unit in any of a variety of locations, as long as the location offers a direct view of the display unit's screen. For easiest viewing, mount the unit near other instrument-panel gauges or on top of the dashboard.

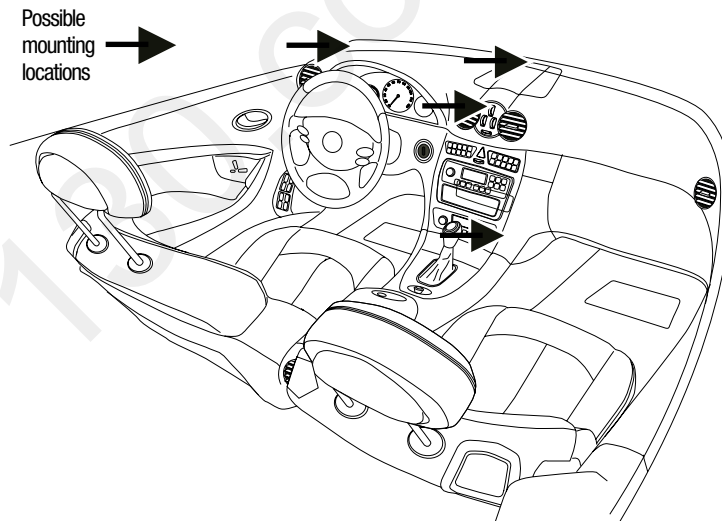

NOTE: The display unit is required to set up and calibrate the MS-8. However, once you have set up the MS-8, you can remove the display unit from the vehicle. (All of the MS-8's equalization and digital signal processing functions will operate without your intervention.) If you do disconnect the display unit after setup, though, you will not be able to make any MS-8 adjustments, and the MS-8's remote control will not function.

If you plan on removing the display unit once your system's setup and calibration is complete, you do not have to choose a permanent mounting location.

INSTALLING THE DISPLAY UNIT

1. Select a safe site for the display unit, and temporarily place it there. Check the viewing angle from the driver's seat while adjusting the display unit's pivot arm. If the viewing angle meets your needs, then skip to Step 2. Otherwise, change the viewing angle as follows:

a) Using the supplied 3mm hex wrench, loosen the recessed hex screw (inside the display base) until the pivot arm is free from the display assembly. The hex screw will remain captive.

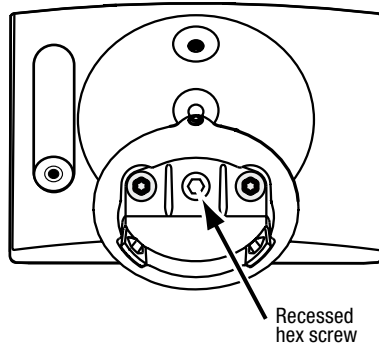

b) Select one of the other two viewing-angle positions. Reassemble the parts in reverse order and tighten the recessed hex screw.

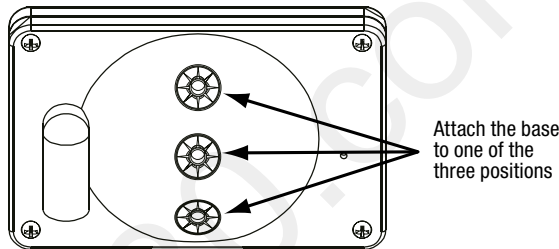

2. At the base, using the supplied 1.5mm hex wrench, loosen (but do not remove) the hex set screw.

3. You can install the display unit using one of the supplied adhesive pads or the supplied mounting screws.

- a) Insert the mounting plate, rotate it 180°, and tighten the hex set screw as shown below.
- b) Wipe the installation-site surface and the exposed mounting plate with one of the enclosed alcohol pads. Allow both to dry.
- c) Remove the protective tape from one side of one of the enclosed adhesive pads, and press the pad against the mounting plate.
- d) Remove the remaining protective tape, and press and hold the display unit to its site for five seconds.

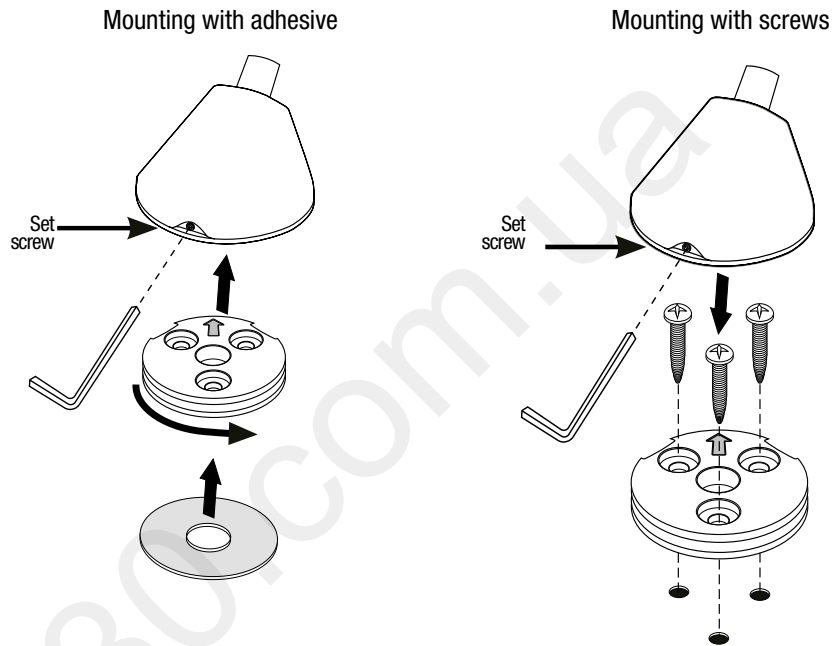

To install the display unit with mounting screws

1. Place the mounting plate at the installation site and rotate it so that its arrow will point toward the hex set screw at the back of the base after it is installed.
2. Holding the mounting plate in position, fasten it to the surface with three enclosed mounting screws.
3. Place the display unit on the mounting plate (180° from its final position). Rotate it a half-turn to the final position. Tighten the hex set screw at the back of the base.
4. Connect the supplied cable to the display unit. If you haven't already done so, route the cable to the main unit and plug it into the main unit's display connector.

Though you can leave the MS-8 RF remote control unmounted, JBL supplies two mounting provisions to secure the remote, making it safe and convenient to operate. Since the remote operates via radio frequency, it is not necessary to aim the remote while using it. NOTE: You can also mount the remote to a convenient surface using a Velcro® strip (not supplied), which allows you to remove the remote to change the battery.

Before mounting the remote

Remove its battery-protection strip by pulling it out in the direction indicated by the arrow.

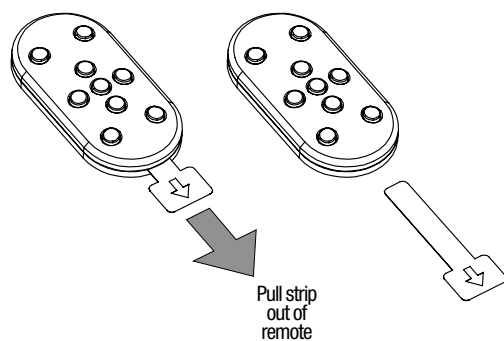

MOUNTING THE REMOTE CONTROL

Surface mounting

1. Find a suitable mounting location with a flat surface that's large enough for the remote. (Note: The remote control is held in the cup by a magnet, so you can mount the cup on a vertical surface if you want.)
2. Ensure that no hazards or wiring are underneath the mounting surface.
3. Remove the remote from the mounting cup. Observe the position of the mounting cup's finger cutout, as shown in the illustration.
4. Use two (2) of the supplied screws or some double-stick tape (not supplied) to attach the mounting cup and trim ring to a flat surface, as shown in the illustration.

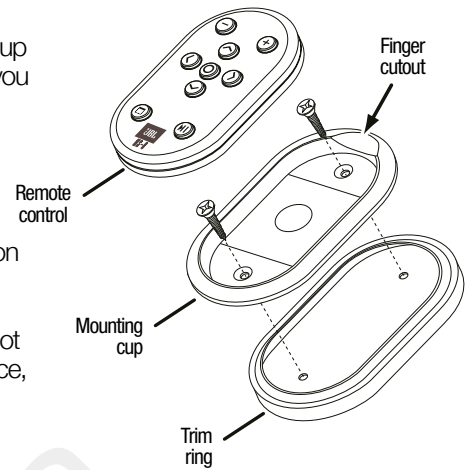

Flush mounting

NOTE: Flush mounting is a custom-installation procedure that may require additional materials that are not supplied with the MS-8.

1. Find a suitable location with a flat surface that's large enough for the remote and has 1/2" (13mm) of clearance underneath.
2. Ensure that no hazards or wiring are underneath the mounting surface.
3. Mark the cutout opening using the inside of the trim ring as a template.
4. Cut the mounting surface just large enough to allow the mounting cup to sit flush against the surface.
5. Remove the remote from the mounting cup. Observe the position of the mounting cup's finger cutout, as shown in the illustration.
6. Secure the mounting cup in place using glue or double-stick tape.

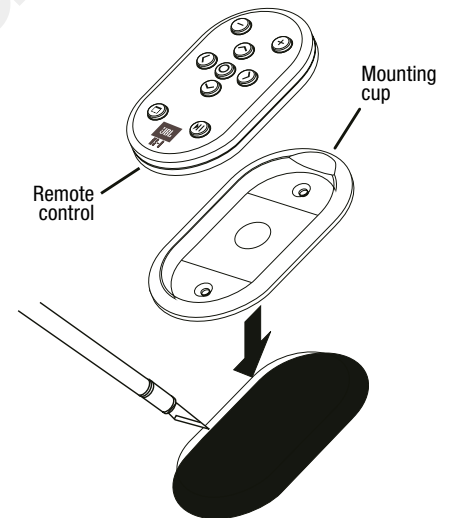

Replacing the battery in the remote control

1. Remove the two screws in the bottom of the remote.
2. Remove the remote's bottom cover.
3. Use a pencil or similar object to push the battery out of its holder.
4. Replace the battery with a new CR2032 3V battery.
NOTE: Insert the battery into the holder with its positive (+) pole facing up.
5. Replace the remote's bottom cover and screws.

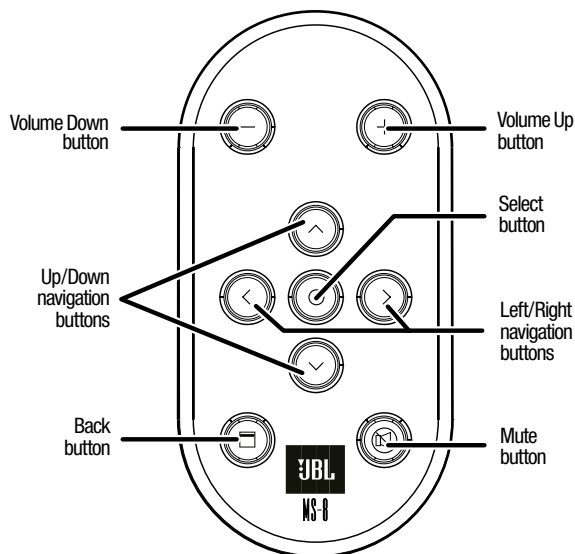

Volume Up and Down buttons: Pressing either of these buttons at any time (except during the setup/calibration process) will display the MS-8's **System Volume** screen, allowing you to change the audio volume. The volume range is between -80dB and 0dB .

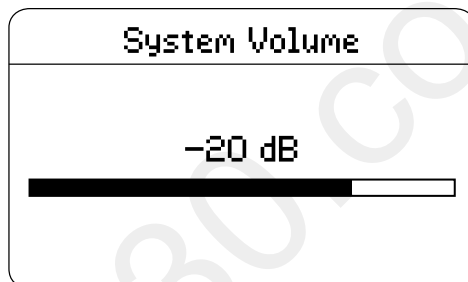

Navigation and select buttons: Use the four navigation buttons (Up, Down, Left and Right) to navigate through the MS-8's various setup and operation screens. The Select button selects or otherwise changes the state of a highlighted item.

Back/menu button: Momentarily pressing this button causes the display to revert to the next-higher menu. Holding the button reverts to your default screen (either the Main Menu or Audio Controls screen) from whatever screen is active at the time. See Default Screen, on page 40.

Mute button: Press to mute the sound; press again to restore the sound. (Pressing either the Volume Up or Volume Down button also restores the sound.)

DISTRACTION WARNING: DO NOT SET UP YOUR MS-8 WHILE DRIVING. We recommend performing these setup procedures while parked at home or after pulling off the road into a position that you are absolutely sure presents no risk. Always obey all traffic laws while driving.

Before you begin

IMPORTANT! The MS-8 will not pass an audio signal through to its outputs until you have configured it according to the setup procedure described below.

The setup procedure consists of four main parts:

Language selection: You will select the language that the MS-8 will use on the display. See , on page 25.

Input setup: The MS-8 will use the included setup CD to analyze and condition the input signal for further processing. See , on page 25.

Output setup: You will configure the crossover settings and identify the output channels. See , on page 26.

Acoustic calibration: The MS-8 will automatically equalize the signal sent to the loudspeakers and optimize their response for up to four seating positions using the included binaural microphone headset. See , on page 32.

You must complete all four of these steps in the above sequence. If you stop the setup procedure before completing all of the steps, the MS-8 will start at the beginning of the last complete section when you turn it back on. Be sure to have your completed Configuration Chart (see page 11) handy. It will make configuring the outputs easy.

Start the MS-8 by turning on the vehicle radio or head unit (or turning the vehicle's key to the ACC position if you've connected the Rem In terminal to ACC power).

Use the remote control's Up and Down navigation buttons to highlight items on the display. Press the remote's Select button to select a highlighted item. Use the remote's Left and Right navigation buttons to make changes in items on the display.

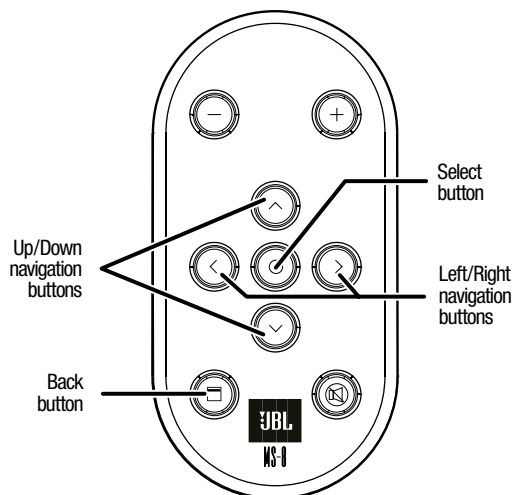

LANGUAGE SELECTION

The first time you power up the MS-8, the **Language** screen will appear on the display. This screen determines the language the MS-8 will use to display all of its setup, calibration and operation menus. When this screen appears, choose a language. The following languages are available: English, Spanish, French, Portuguese, German, Dutch, Italian, Danish, Norwegian, Swedish and Finnish.

NOTE: After the setup and calibration process, you can change the language using the Main Menu's System Settings option. See *System Settings Menu*, on page 40.

INPUT SETUP

Once you have chosen a language, the MS-8 will display **Input Setup**.

IMPORTANT: You must use the calibration CD provided with the MS-8 for this step. If your system does not have a CD player, you can convert the CD to a .WAV file for use with a portable media player or other audio source. The file format you use MUST be lossless, or the calibration process will not be accurate.

- **If you are using an aftermarket head unit** and have connected the head unit's front left output and right line outputs to the MS-8's line inputs 1 and 2, you may select **Skip Input Setup** and go directly to *Output Setup*, on page 26.
- **If you are using a factory-installed stereo** that you connected to the MS-8's Hi Level input or line inputs, continue with steps 1–3, below.

1. Set the head unit's bass, treble, balance and fader controls to their "flat" or center positions. If possible, defeat the factory system's additional processing (Dolby® Pro Logic II, Logic 7®, seating-position selector, user-selectable equalization, etc.). Consult your vehicle owner's manual for instructions on how to do it.
2. Insert the calibration CD supplied with the MS-8 into the source unit's Play button and select **Continue**.

While the CD is playing, the MS-8 will analyze the input signal to ensure that it is receiving the correct signal and that both right and left signals are present. The MS-8's display will show **Signal**, **Level** and **Balance**. An **OK** must appear next to each one before you can continue.

- If **None** appears next to **Signal**, be sure that the head unit is outputting a signal (increase the volume control) and/or check the MS-8's input connections.
 - If **Noisy** appears next to **Signal**, check to see that the head unit's volume control isn't all the way up; turn off the car's engine (if the car is running), but be sure not to turn the key past ACC.
 - If **High** or **Low** appears next to **Level**, slowly adjust the head unit's volume control until **OK** appears.
 - If **Left** or **Right** appears next to **Balance**, slowly adjust the head unit's balance control until **OK** appears.
3. Once **OK**, **OK**, **OK** appear on the display, stop making adjustments to the head unit, and select **Continue** while the CD is playing. NOTE: Do NOT make any other adjustments to the head unit during the entire input setup procedure.

The display will read **Acquiring** while the MS-8 analyzes and corrects the input signal. Once the procedure is complete (it might take up to a minute or two), follow the instructions on the screen: Turn the head unit's volume down, remove the CD and select **Continue**.

OUTPUT SETUP

Next, the MS-8 will display **Xover Setup**. During Xover Setup, you must tell the MS-8 which speakers are connected to the system, and you must select the crossover characteristics for all of the system's speakers. Referring to the Configuration Chart that you filled out when you connected the MS-8 will make this process easy. During Xover Setup and Channel Selection, you must enter the information according to the specific sequence that the MS-8's display presents.

A note about crossovers

In general, your car stereo's small speakers are designed to reproduce high frequencies, while its large speakers are designed to reproduce low frequencies. Larger speakers do a poor job of reproducing high frequencies, and smaller speakers are not able to reproduce low frequencies and may even be damaged by them.

A crossover is a filter or combination of filters that limit the sounds that are sent to a particular speaker so that it receives only the frequencies that it can safely reproduce. The MS-8 features a sophisticated crossover system that you can set to get the best performance from whatever type of speaker system is installed in your vehicle.

In the MS-8, a crossover (or filter, abbreviated "Xover" on the MS-8 display) frequency refers to the frequency at which the sounds sent to that speaker will begin to be attenuated. The crossover filter slope refers to the rate at which the sounds will be attenuated. The MS-8's crossover contains two types of filters:

- *High-pass filters*, which send the frequencies above the crossover frequency to a speaker while attenuating the frequencies below the crossover frequency. This type of filter is used to prevent lower frequencies from reaching smaller speakers.
- *Low-pass filters*, which send the frequencies below the crossover frequency to a speaker while attenuating the frequencies above the crossover frequency. This type of filter is used to prevent higher frequencies from reaching larger speakers.

A high-pass filter can be combined with a low-pass filter to create a third type of filter, called a *band-pass filter*. A band-pass filter sends the band of frequencies between the high-pass and low-pass crossover frequencies to a speaker while attenuating the frequencies below the high-pass crossover frequency and above the low-pass crossover frequency. This type of filter is used to prevent lower and higher frequencies from reaching midrange speakers in three-way speaker systems.

The most important thing that determines your selection of an MS-8 crossover filter's frequency and slope is making sure that your system's small speakers don't receive too much bass, which can cause the sound they reproduce to be distorted and can even damage them.

For example, an 80Hz high-pass filter will remove frequencies below 80Hz from the signal that the MS-8 sends to a smaller speaker. However, it may not completely remove those frequencies; a 6dB per octave filter slope will still allow the speaker to receive 1/4 of the signal's power at 40Hz, while a 24dB/octave filter slope will allow the speaker to receive almost no power at 40Hz and will keep the speaker from receiving too much bass. **We recommend using 24dB/octave slopes between subwoofers and midrange speakers and between midrange speakers and tweeters.**

If you make a mistake

If you make a mistake and need to reenter Output Setup information, you must abort the Xover Setup process and start it again. To abort the process:

1. Hold the remote's Back/Menu button until the **Main Menu** screen appears.
2. Select **Calibration/Setup**; then select **Input/Output Setup**.
3. When the **Warning Message** screen appears, select **Continue**.
4. When the **Input Setup** screen appears, select **Skip Input Setup**.
5. The MS-8 will display the **Xover Setup, Sub** screen. Continue below.

Subwoofer

1. Select **Sub** (for subwoofer).
2. The MS-8 will then display **None, 1, 2**. Use the remote's Up and Down navigation buttons to highlight one of these options, and press the Select button to select it. Your audio system's subwoofer configuration determines which option you should select.

For example, if you have one subwoofer being powered by one amplifier channel (either an outboard amplifier or an MS-8 amplifier channel), select **1**. If you have two subwoofers, each powered by its own amplifier channel, connected to separate MS-8 outputs, select **2**. If you have two subwoofers, each powered by its own amplifier, but those amplifier channels are connected to a single MS-8 output, select **1**.
3. If you've chosen **None**, skip to *Front speakers*, on page 28.
4. If you've chosen **1** or **2**, the display will then read **Subsonic Filter**. This screen enables you to choose the subsonic (that is, infrasonic) high-pass filter for the system's subwoofer(s). Use the remote's Left and Right navigation buttons to display a frequency between 20Hz and 50Hz, and press the Select button to select it. If you're not sure which frequency to choose, we recommend using 20Hz.
5. The MS-8 will then display **Subsonic Slope**. This screen enables you to determine the subsonic filter's attenuation rate. Use the Up and Down navigation buttons to highlight an attenuation rate, and press the Select button to select it. If you're not sure which rate to choose, we recommend using 12dB/octave.
6. The MS-8 will then display **Sub/Front Xover**. This screen enables you to determine the crossover frequency between the subwoofer and the front left and right speakers. You should determine this frequency by the amount of bass your left/right speakers can safely produce, considering the amount of power that will be applied to them. Use the Left and Right navigation buttons to display a frequency between 50Hz and 200Hz, and press the Select button to select it. If you're not sure which frequency to choose, we recommend using 80Hz.
7. The MS-8 will then display **Sub/Front Slope**. This screen enables you to choose the rate of attenuation between the subwoofer and the front speakers. The speakers' performance characteristics should determine your selection. Use the Up and Down navigation buttons to highlight an attenuation rate, and press the Select button to select it. If you're not sure which rate to choose, we recommend using 24dB/octave.

Front speakers

1. The MS-8 will then display **Xover Setup > Sub, Front**. Select **Front**.
2. The MS-8 will then display **Front**, with the options **1 way**, **2 way**, and **3 way**. These options refer to the number of MS-8 s output channels that will be devoted to driving your front speakers.

MS-8 Crossover Configurations

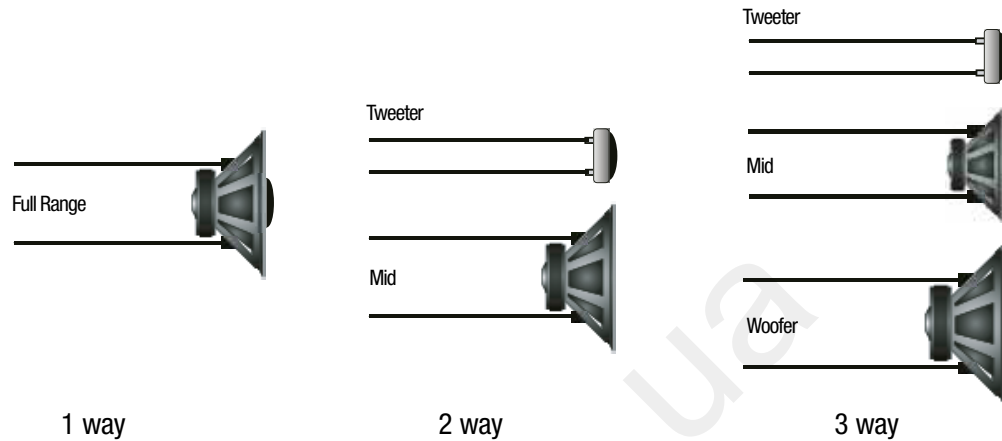

Use the Up and Down navigation buttons to highlight one of these options, and press the Select button to select it. The configuration of your system’s front speakers determines your choice.

For example: If your front left and right speaker system consists of a pair of coaxial speakers (one left and one right), or components with their own passive crossover connected to two of the MS-8 s outputs (either speaker outputs or line outputs connected to an outboard power amplifier), choose **1 way**. If your front speakers consist of a component system where the tweeters and the midranges will each be connected to separate output channels, choose **2 way**. If your front system consists of separate tweeters, midrange and midbass, with each connected to a separate channel, choose **3 way**.

3. If your audio system does not have a subwoofer, the MS-8 will then display **Front Hi Pass**. This screen enables you to choose the subsonic high-pass filter for the system s speakers. Use the Left and Right navigation buttons to display a frequency between 20Hz and 100Hz, and press the Select button to select it. If you re not sure which frequency to choose, we recommend using 20Hz. Alternately, you may want to use this setting to prevent your front speakers from receiving too much bass, which can cause distortion at higher listening levels. If your front speakers are 6" or larger, we suggest a setting between 20Hz and 40Hz. If your front speakers are 5" or smaller, we suggest a setting between 40Hz and 60Hz.
4. The MS-8 will then display **Front Hi Pass Slope**. This screen enables you to choose the subsonic filter’s rate of attenuation. Use the Up and Down navigation buttons to highlight a filter slope, and press the Select button to select it. If you’re not sure which rate to choose, we recommend using 12dB/octave.

5. If in Step 2 you selected 1 way: Skip to *Center speaker*, on page 29.

6. If in Step 2 you selected 2 way

- a) The MS-8 will display **Front Lo/Hi Xover**. This screen enables you to choose the crossover frequency between the front midrange and tweeter (or between a separate midbass driver and a midrange/tweeter). Use the Left and Right navigation buttons to display a frequency between 50Hz and 10kHz, and press the Select button to select it. If you're using separate tweeters connected to the MS-8's amplifier or to an additional amplifier, we recommend using a setting of 3500Hz or higher.
- b) The MS-8 will then display **Front Lo/Hi Slope**. This screen enables you to choose the rate of attenuation of the filter between the midrange and tweeter. Use the Up and Down navigation buttons to highlight a filter slope, and press the Select button to select it. If you're using separate tweeters (as discussed in Step 5a), we recommend using 24dB/octave.

7. If in Step 2 you selected 3 way

- a) The MS-8 will display **Front Lo/Mid Xover**. This screen enables you to choose the crossover frequency between the front midbass and midrange. Use the Left and Right navigation buttons to display a frequency between 100Hz and 10kHz, and press the Select button to select it. The design and performance of your front speakers determines which frequency you should choose.
- b) The MS-8 will then display **Front Lo/Mid Slope**. This screen enables you to choose the attenuation rate of the filter between the midbass and midrange. Use the Up and Down navigation buttons to highlight an attenuation rate, and press the Select button to select it. The design and performance of your front speakers determines which rate you should choose.
- c) The MS-8 will then display **Front Mid/Hi Xover**. This screen enables you to choose the crossover frequency between the front midrange and tweeter. Use the Left and Right navigation buttons to display a frequency between 200Hz and 10kHz, and press the Select button to select it. The design and performance of your front speakers determines which frequency you should choose. If you're using separate tweeters connected to the MS-8's amplifier or to an additional amplifier, we recommend using a setting of 3500Hz or higher.
- d) The MS-8 will then display **Front Mid/Hi Slope**. This screen enables you to choose the attenuation rate of the filter between the midrange and tweeter. Use the Up and Down navigation buttons to highlight an attenuation rate, and press the Select button to select it. The design and performance of your front speakers determines which rate you should choose. If you're using separate tweeters (as discussed in Step 7c, above), we recommend using 24dB/octave.

Center Speaker

1. The MS-8 will then display **Xover Setup > Sub , Front , Center**. Select **Center**.
2. The MS-8 will then display **Center**, with the options **None, 1 way, 2 way**. Use the Up and Down navigation buttons to highlight one of these options, and press the Select button to select it. The configuration of your system's center speaker determines your choice.

For example: If your center speaker system consists of a coaxial speaker or component with its own passive crossover connected to one of the MS-8's outputs (either its speaker outputs or its line outputs connected to an outboard power amplifier), choose **1 way**. If your center speaker consists of a component system where the tweeter and the midrange will each be connected to separate MS-8 output channels, choose **2 way**.

NOTE: The available center-speaker, side-speaker and rear-speaker options will depend on the number of MS-8 channels that are available after you have set up the subwoofer and front speakers. For example, if you are using two subwoofer channels and three-way front speakers, then all eight of MS-8's channels will have been allocated, and the only option that will be displayed for the center speaker (as well as the side and rear speakers) will be **None**. If you have selected a single subwoofer channel and three-way front speakers, seven of MS-8's eight channels will have been allocated, and the options displayed for the center speaker will be **None** and **1**.

3. The MS-8 will then display **Center Hi Pass**. This screen enables you to choose the high-pass filter for the center speaker. Use the Left and Right navigation buttons to display a frequency between 50Hz and 10kHz, and press the Select button to select it. If you're not sure which frequency to choose, we recommend using 80Hz.
4. The MS-8 will then display **Center Hi Pass Slope**. This screen enables you to choose the subsonic filter's attenuation rate. Use the Up and Down navigation buttons to highlight a rate, and press the Select button to select it. If you're not sure which rate to choose, we recommend using 24dB/octave.
5. If in Step 2 you selected **2 way**:
 - a) The MS-8 will display **Center Lo/Hi Xover**. This screen enables you to choose the crossover frequency between the center midrange and tweeter. Use the Left and Right navigation buttons to display a frequency between 50Hz and 10kHz, and press the Select button to select it. If you're using separate tweeters connected to the MS-8's amplifier or to an additional amplifier, we recommend using a setting of 3500Hz or higher.
 - b) The MS-8 will then display **Center Lo/Hi Slope**. This screen enables you to choose the rate of attenuation of the filter between the midrange and tweeter. Use the Up and Down navigation buttons to highlight a filter slope, and press the Select button to select it. If you're using separate tweeters (as discussed in Step 5a), we recommend using 24dB/octave.

Side speakers (side or rear speakers)

NOTE: If your system has side AND rear speakers, configure the side speakers in this section (**Side**) and the rear speakers in the next section (**Rear**). If your system has only side OR rear speakers, configure those speakers in this section (**Side**), and skip the next section (**Rear**).

1. The MS-8 will then display **Xover Setup > Sub, Front, Center, Side**. Select **Side**.
2. The MS-8 will then display **Side**, with the options **None** and **1 way** (Separate outputs for two-way speakers are not available for side or rear speakers.) Use the remote's Up and Down navigation buttons to highlight one of these options, and press the Select button to select it.
3. The MS-8 will then display **Side Hi Pass**. This screen enables you to choose the high-pass filter for the side speakers. Use the remote's Left and Right navigation buttons to display a frequency between 50Hz and 10kHz, and press the Select button to select it. We recommend using at least 100Hz.
4. The MS-8 will then display **Side Hi Pass Slope**. This screen enables you to choose the rate of attenuation of the filter between the midrange and tweeter. Use the Up and Down navigation buttons to highlight a filter slope, and press the Select button to select it. We recommend using 24dB/octave.

Rear speakers

1. The MS-8 will then display **Rear**, with the options **None** and **1 way**. (Separate outputs for two-way speakers are not available for side or rear speakers.)
2. Use the remote's Up and Down navigation buttons to highlight one of these options, and press the Select button to select it. NOTE: If you are using only one set of speakers in the back of the car or if there are no speakers in the back of the car, select **None**.
3. The MS-8 will then display **Rear Hi Pass**. This screen enables you to choose the high-pass filter for the rear speakers. Use the remote's Left and Right navigation buttons to display a frequency between 50Hz and 10kHz, and press the Select button to select it. We recommend using at least 100Hz.
4. The MS-8 will then display **Rear Hi Pass Slope**. This screen enables you to choose the filter's attenuation rate. Use the Up and Down navigation buttons to highlight a slope, and press the Select button to select it. We recommend using 24dB/octave.

The MS-8 will then display the **Xover Setup** menu, which lists all the speakers you have set up. If you need to make corrections, select the appropriate speaker location from the menu, and reenter the information as well as all of the information for the speakers that follow. When you are finished with all of the output-setup settings, select **Done**.

Channel selection

The MS-8 will then display the **Channel Selection** menu. This menu enables you to assign the outputs that you configured in all the Xover Setup menus to specific output channels, by number. This menu will display only valid choices (according to your entries in the Xover Setup menus). Select the output channel based on the connections that you documented in the Configuration Chart you filled out on page 11, in the audio outputs section:

1. If a speaker or amplifier is connected to the MS-8's Channel 1, select **Channel 1** from the Channel Selection menu.
2. The MS-8 will display the **Channel 1** menu, which will list the available choices based on the entries that you made in Xover Setup. The following choices may be available:

FL – Front left (full-range speaker)

FL Hi – Front left tweeter (or midrange/tweeter combination with passive crossover)

FL Mid – Front left midrange

FL Lo – Front left low (woofer, midbass or midrange)

FR – Front right (full-range speaker)

FR Hi – Front right tweeter (or midrange/tweeter combination with passive crossover)

FR Mid – Front right midrange

FR Lo – Front right low (woofer, midbass or midrange)

Sub 1 – Subwoofer 1

Sub 2 – Subwoofer 2

Ctr – Center (full-range)

Ctr Hi – Center tweeter

Ctr Lo – Center low (woofer or midrange)

SL – Side left

SR – Side right

RL – Rear left

RR – Rear right

3. If a speaker or amplifier is connected to the MS-8's Channel 2, select **Channel 2** from the Channel Selection menu and repeat the procedure from Step 2.
4. Repeat the procedure for each channel to which a speaker or amplifier is connected. Skip channels that are not connected to speakers or additional amplifiers. If you make a mistake, select the channel that you want to correct, and then enter the correct selection. The MS-8 keeps track of the number of channels that you have used and will not allow duplicate entries. Check your entries carefully against the Configuration Chart you filled out on page 11. Once you're satisfied that everything is correct, select **Done**.

Output diagnostics

The MS-8 will then display the **Output Diagnostics** menu. We provide this screen to help you confirm that your connections and channel assignments are correct before you proceed to the next step.

Select any of the displayed speaker locations to hear pink noise through all of the channels dedicated to that location. For example, if you've set up a three-way front system, selecting **Front Right** will cause the MS-8 to send test noise to the three channels you've designated as Front Right (hi, mid and lo).

Listen carefully as you move through the speaker locations. If you've made a mistake (that is, if the noise is coming from a speaker other than the one you've selected), you may be able to correct the mistake by reconnecting the RCA or speaker-wire connectors on the MS-8's output.

If you can't correct the mistake by changing connections, correct your Configuration Chart and hold the remote's Back/Menu button to return to the Xover Setup menu (see the *If you make a mistake* sidebar on page 27). You will need to enter the all of the correct information again from the beginning of the section.

Once you've determined that all connections and selections are correct, select **Done** in the Output Diagnostics menu. The MS-8 will display the **Speaker Configuration Complete** screen. When you're ready to begin the acoustic calibration procedure, select **Continue**.

ACOUSTIC CALIBRATION

The last step in setting up the MS-8 is making acoustic measurements that will help the MS-8 optimize the sound at the driver's seating position. (You may also make acoustic measurements to optimize the sound at three additional seats.) To get the best results for you and a single passenger, make measurements in the driver's and front passenger's seats.

The MS-8 will display **Error > Please Connect Microphone**.

Connect the included binaural microphone headset to the MS-8's Mic input jack. (The MS-8 will not continue the calibration process until you connect the microphone.) Carefully route the microphone's cable to the driver's seat, leaving enough excess wire to accommodate the movement of your head. Sit in the driver's seat and place the headset mic on your head. Be sure that the left and right microphones are on the correct ears!

Select **Continue**. The MS-8 will display **Set Volume > -20dB**.

- If the MS-8's internal amplifier is set to drive the front speakers, leave the volume set at -20dB.
- If an external, higher-powered amplifier is driving the front speakers, use the remote's Volume Down button to set the volume to a level lower than -20dB.

In either case, the test-signal sweeps that you will hear during acoustic calibration should be about as loud as someone sitting in the passenger's seat speaking at a normal conversational level. Performing acoustic calibration with a level that's too high will negatively affect the calibration results. See *Volume Up and Volume Down buttons*, on page 35.

After setting the volume, press the Select button. The MS-8 will display **Driver's Seat > Acoustic Measurement 1of4 > Look Forward**

1. Make sure that you have positioned the binaural microphone headset over your ears and that you are sitting in the driver's seat. Look straight forward.
2. Select **Go**. The MS-8 will play a series of test signals.
3. Hold your head still until the test signals stop and the next screen (**measurement 2of4 > Look Forward**) appears.
4. Select **Go** and continue looking forward while the MS-8 plays the second series of test signals.
5. Hold your head still until the test signals stop. NOTE: The subwoofer test signal in measurements 2, 3 and 4 lasts a little longer than the other test signals, so be sure to keep your head still until it has finished and the next screen (**measurement 3of4 > Look Driver Side Mirror**) appears.
6. Turn your head toward the driver's side-view mirror for the third measurement and select **Go**.
7. Hold your head still until the test signals stop and the next screen (**measurement 4of4 > Look Passenger Side Mirror**) appears.
8. Turn your head toward the passenger's side-view mirror for the final measurement and select **Go**.
9. Hold this position until the test signals stop and the MS-8 displays **Driver's Seat**, with several options:

Next seating position: Selecting this option will perform acoustic calibration for the front passenger seat.

NOTE: To calibrate for the front passenger seat, you'll need to sit in the front passenger seat while the MS-8 makes the measurements. If you wish to calibrate for the passenger's seat, move to that seat before starting the next section.

After the front passenger-seat calibration is complete, **Next seating position** will refer to the rear driver-side seat, and then the rear passenger-side seat. To calibrate for those seating positions, you must move to those seats before beginning calibration.

Next seating position repeats steps 1–9 for up to three additional seating positions. When you have completed optimizing the sound for all positions, select **Done**.

Remeasure seating position: Selecting this option remeasures the seating position that has just been measured. You can select this option if you think you've made a mistake, if loud noises were present during any of the test-signal sweeps, if the sweeps were much louder than someone speaking at a normal volume or if you want to remeasure the seating position for any other reason.

Quit: Selecting this option aborts the calibration procedure and returns to the beginning of acoustic calibration.

Done: Selecting this option will complete the calibration process if you do not wish to measure additional seating positions. The MS-8 will display **Acoustic Measurement Complete > Please wait** while it calibrates the system. When the calibration is complete, the MS-8 will display **Main Menu**.

Disconnect the microphone, insert your favorite CD and have a listen. Additional adjustments are available in the Main Menu (see *Main Menu*, on page 35).

130.com.ua

VOLUME UP AND DOWN BUTTONS (on the remote control)

Pressing either of these buttons at any time (except during the setup/calibration process) will display the MS-8's **System Volume** screen, allowing you to change the audio volume. The volume range is between -80dB and 0dB .

For the best results, leave the head unit's volume control set at the level that produced the **OK, OK, OK** readings on the display during the setup process (see *Input Setup*, on page 25), and use the MS-8's Volume Up and Volume Down buttons to control the system's volume. You may also use the head unit's volume control to control the system's volume.

MAIN MENU

When you complete the calibration process, the MS-8 will display the **Main Menu** screen. From MS-8's Main Menu, you can navigate to all of the MS-8's functions and adjustments.



IMPORTANT: If you decide not to install the MS-8's display permanently, the Main Menu and all of the MS-8's adjustments will not be available. In this case, set the MS-8's System Volume to -6dB (see *Volume Up and Volume Down buttons*, on this page), and unplug the display unit. Be sure to store the display unit, cable and remote control in a safe place in case you may want to reconfigure the system or make other adjustments.

The Main Menu gives you the following selections:

Input Selection: This screen lets you choose a connected head unit or the Aux input as the active source of audio. See *Input Selection menu*, on page 36.

Audio Controls: This screen lets you adjust the system level, tone controls and 31-band graphic EQ, and engage/defeat the MS-8's Logic 7 processing, digital signal processing (time correction and equalization) and seating-position optimization. The MS-8 also provides an option to reset all controls to their factory defaults. See *Audio Controls menu*, on page 36.

Favorites: This option lets you store and recall currently active audio settings (you can store and recall up to five different combinations of settings). See *Favorites menu*, on page 39.

Calibration/Setup: This selection performs the calibration procedures as documented in this manual. See *Calibration/Setup*, on page 24. NOTE: If you would like to recalibrate the acoustic performance of the system, you may enter its Calibration/Setup section, choose Acoustic Calibration and re-tune the system without repeating the input-setup, xover-setup and channel-selection procedures.

System Settings: This selection accesses the MS-8 s operational and display settings. See *System Settings Menu*, on page 40.

INPUT SELECTION MENU

Input Selection	
Head Unit	Active
AUX	

This menu lets you select between the MS-8 s Head Unit input (either the line-input connections or Hi Level input connections) and the Aux input connections. The word Active indicates which input is currently active.

AUDIO CONTROLS MENU

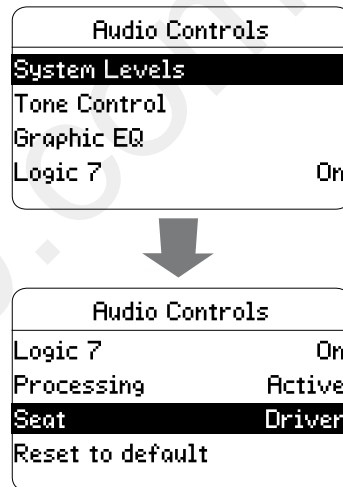

This menu provides control of all of the MS-8 s audio adjustments.

NOTE: Pressing the Select button while making any adjustment returns the adjustment to the center position.

System Levels: This screen lets you adjust the levels of the Aux input and the system s speakers. Use the Left and Right navigation buttons to vary the levels. (NOTE: If the system has both side and rear speakers, the Fader control will adjust between the front speakers and both the side and rear speakers in tandem. It is not possible to adjust the balance between the side and rear speakers.)

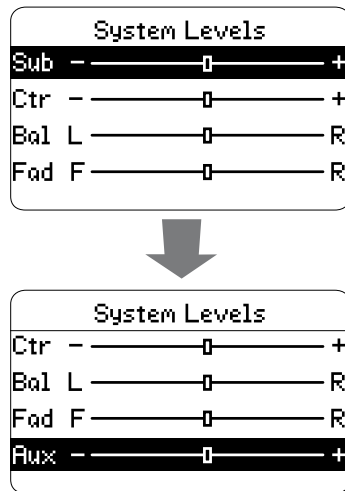

Note for systems that include a center-channel speaker: Logic 7 processing steers all mono information to the center channel. At first, the sound may seem wrong if you're not used to listening with the Logic 7 system. However, after listening for an extended period, you'll find vocal and instrument placement with Logic 7 enabled and the center-channel level in the center position to be natural sounding and consistent. If you listen to a lot of news, sports or talk radio, you may want to attenuate the center channel – you can even save a Favorite setting with such an adjustment. In any case, you can always set the level of the center channel according to your preference.

Tone Control: This selection lets you adjust the system's overall tone quality. The bass control and treble control are shelving-type controls, with $\pm 10\text{dB}$ of boost and cut at 20Hz and 20kHz, respectively. The midrange control is a peak-and-dip type with a Q of 0.26 that offers $\pm 10\text{dB}$ of boost and cut at 650Hz. Use the Left and Right navigation buttons to vary the levels.

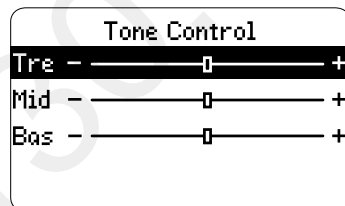

Graphic EQ: The MS-8's graphic equalizer is a sophisticated tone control that divides the audio spectrum into 31 bands, each approximately a third of an octave wide. This format allows you to fine-tune the system's sound with extreme precision. Each band allows $\pm 10\text{dB}$ of boost or cut at the band's center frequency. We have designed the equalizer's circuitry to minimize destructive interaction between adjacent bands, giving you precise control with superior sound quality.

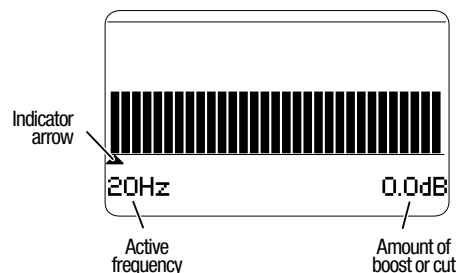

The arrow indicates the selected band; the band's center frequency is indicated on the left side of the screen; the amount of boost or cut that you apply is indicated on the right side of the screen.

Use the Left and Right navigation buttons to select the frequency band you want to adjust, and use the Up and Down navigation buttons to make the adjustments. Each press of an Up or Down button changes the level by 0.5dB. As you apply boost or cut, the selected band will increase or decrease in size on the screen to indicate the relative change in level.

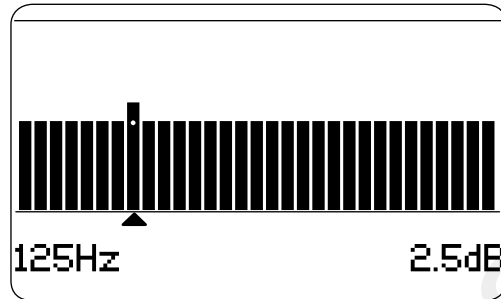

IMPORTANT: The MS-8's digital volume and equalization work differently than standard analog controls. Boosting the MS-8's subwoofer-level control, bass-tone control and the low bass bands in the 31-band EQ to their near-maximum, and setting the MS-8's System Volume control to 0dB, will cause severe clipping (distorted sound) that may damage your system's loudspeakers.

Logic 7: Logic 7 technology creates an ideal 5.1-channel or 7.1-channel surround-sound listening environment from two-channel source material. Logic 7 processing widens the stereo soundstage and increases the sense of sonic envelopment, making the vehicle's interior boundaries seem to disappear. The music sounds as though it exists on its own, rather than coming from speakers. We have specifically tuned the MS-8's Logic 7 for use in vehicles. It includes processing for the center-channel speaker (if one is present in the vehicle's system).

You can turn Logic 7 on and off by pressing the Select button while Logic 7 is highlighted in the Audio Controls menu.

Processing: The Audio Controls **Processing** option activates and defeats the MS-8's digital time-correction and acoustic-equalization circuitry. Using the Select button to switch between **Active** and **Defeat** will let you hear how the MS-8's advanced digital signal processing dramatically improves your system's performance.

Seat: You can optimize the sound for any of the seating positions that you measured during the setup process. Pressing the Select button cycles through the available positions: **Driver, Passenger, Front, Rear, All**. Front or Rear optimizes both front seats or both rear seats as the preferred listening position. All is a general setting that will produce good sound for any seating position.

Reset to default: This setting restores all of the audio controls to their default settings. The default settings are:

System Levels: All controls centered

Tone Control: Flat (all controls centered)

Graphic EQ: Flat (all controls centered)

Logic 7: On

Processing: Active

Seat: Driver

FAVORITES MENU

The MS-8 provides five **Favorites** positions that let you store the system's currently active audio settings. The system stores all audio and input selection settings in a Favorites setting (except the Aux volume setting). This feature lets you tailor the sound for a certain type of music or a certain driver, and save and recall the settings at any time.



To store a Favorite

Select **Save Favorites**. The Save Favorites screen will appear.

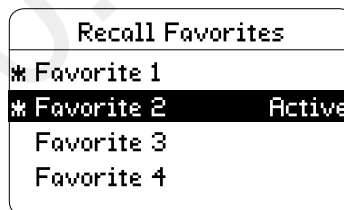
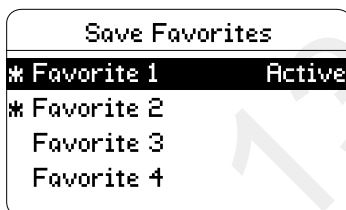

Use the Up and Down navigation buttons to select the Favorites position, then press the Select button to save the current settings there. An asterisk (*) will appear next to the selection to indicate into which Favorites position you have stored the current configuration.

To recall a stored Favorite

Select **Recall Favorites**. The **Recall Favorites** screen will appear (see above). Use the Up and Down navigation buttons to select the Favorites position, then press the Select button to activate it. The word **Active** will appear to the right of the active setting's number. This selection will remain until you choose another Favorites setting or you adjust any of the audio settings.

SYSTEM SETTINGS MENU

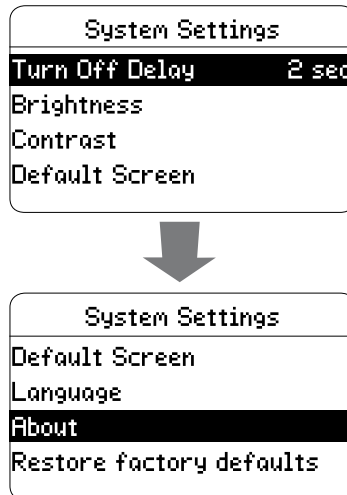

This menu lets you adjust the MS-8 s various system settings:

Turn off delay: This setting lets you select a delay time for the MS-8 to turn additional amplifiers off via its Remote Out terminal when the MS-8 goes into its standby mode. The options are zero seconds (no delay), two seconds or five seconds. The factory default is two seconds.

Brightness: This setting lets you adjust the display s brightness. Press the Select button; then use the Left and Right navigation buttons to change the brightness. When you're finished, press the Select or Back button to return to the System Settings screen.

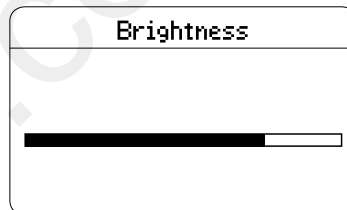

Contrast: This screen lets you adjust the display s contrast. Press the Select button; then use the Left and Right navigation buttons to change the contrast. When you're finished, press the Select or Back button to return to the System Settings screen.

Default Screen: This setting lets you choose which screen the MS-8 will default to when you turn it on – the Main Menu screen or the Audio Controls screen.

Language: This screen lets you select the MS-8 s screen language. The following languages are available: English, Spanish, French, Portuguese, German, Dutch, Italian, Danish, Norwegian, Swedish and Finnish.

About: This screen displays the firmware versions loaded in your MS-8.

Restore Factory Defaults: This option erases ALL of the MS-8 s settings and filters, and returns the unit to its out-of-the-box state.

RESETTING THE MICROPROCESSOR

If your MS-8 stops responding to the remote control (even after you've replaced the remote's battery) or fails to operate in the way this manual describes, use a pen or similar pointed object to press the Reset button on the main unit (see *Connections*, on page 5.) NOTE: Pressing the Reset button will NOT erase your calibration settings.

Need More Information?

For more information, visit www.JBL.com for the latest technical information and other important MS-8 details.

130.com.ua

If your MS-8 doesn't seem to be working the way it should, read this section to see if the problem and possible solution are listed here. If, after you try all of the solutions listed here, the problem persists, contact JBL Customer Service at 516.255.4JBL (4525).

POWER		
Symptom	Possible Cause	Solution
The power LED does not illuminate.	The +12V, Gnd or Rem In terminals are not properly connected.	Confirm that all power connections are correctly made according to this manual. See <i>Connections: Power</i> , on page 5.
	The fuse is blown.	Replace the fuse with an identical 25A fuse.
The power LED illuminates, but the display does not illuminate.	The display is not properly connected.	Check the connections at display and at main unit. See <i>Connections: Display</i> , on page 14.
	The MS-8's microprocessor needs to be reset.	Press Reset button with a pen or similar object. See <i>Resetting the Microprocessor</i> , on page 41.
SOUND		
Symptom	Possible Cause	Solution
There is no sound in all channels.	Improper input connections.	Confirm that all the required channels of the source unit are properly connected. See <i>Audio Inputs</i> , on page 7.
	Calibration/setup procedure has not been performed.	Perform the calibration/setup procedure. (The procedure must be performed before the MS-8 will pass an audio signal through to its outputs.) See <i>Calibration/Setup</i> , on page 24.
	Incorrect input is selected on the MS-8	Select the correct input using the MS-8's Input Selection menu. See <i>Input Selection Menu</i> , on page 35.
	The MS-8's System Volume is turned all the way down.	Set the MS-8 System Volume at -20dB. See <i>Acoustic Calibration</i> , on page 32, and <i>Volume Up and Volume Down Buttons</i> , on page 35.
	The head-unit or source-unit volume control is turned all the way down.	Turn the head-unit or source unit volume up to a normal level.

SOUND		
Symptom	Possible Cause	Solution
There is no sound in one or more channels.	Improper input connection.	Confirm that all required channels of the source unit are properly connected. See <i>Audio Inputs</i> , on page 7.
	Improper output connection.	Confirm that the speaker in question is properly connected to the MS-8 s speaker output. See <i>Audio Outputs</i> , on page 10.
		If the speaker is connected to an outboard amplifier, confirm that the outboard-amplifier channel is properly connected to the MS-8. See <i>Audio Outputs</i> , on page 10.
	Improper speaker connection to outboard amplifier.	Confirm that the speaker is properly connected to the outboard amplifier.
	Outboard amplifier channel is not functioning.	Troubleshoot the outboard amplifier and replace it, if necessary.
The sound comes from the incorrect speaker.	Incorrect output connection.	Confirm that the speaker is connected to the correct MS-8 speaker output or to the correct outboard-amplifier channel.
	Incorrect channel assignment.	Perform the Input Setup (page 25) and Output Setup (page 26) procedures again. (See the <i>If you make a mistake sidebar</i> , on page 27.) Before beginning the procedures, make sure to confirm and document which speakers are connected to which MS-8
Sound comes from only the left or right side speakers; or sound comes from only the front or rear speakers.	The Balance and/or Fader controls are set all one way or another.	Use the MS-8 s System Levels screen to set the controls to their center positions. See <i>Audio Controls Menu</i> , on page 35.

SOUND		
Symptom	Possible Cause	Solution
The source connected to the Aux input is too quiet or too loud.	The Aux input level is not properly set.	Use the MS-8 s System Levels screen to set the Aux level so that the Aux source s level matches the level of the head unit source. See <i>Audio Controls Menu</i> , on page 35.
	The source player s volume control is set too low.	Set the source player s volume control to a higher level.
The sound in all speakers is distorted.	The MS-8 s System Volume control and the head unit s volume control are not properly adjusted.	<p>If you have connected the front speakers to be driven directly by the MS-8 s internal amplifier, set the MS-8 s System Volume at -20dB.</p> <p>If you have connected the front speakers to an external, higher-powered amplifier that is connected to the MS-8 s line outputs, set the MS-8 s System Volume to a level lower than -20dB.</p> <p>In either case, you should use the head unit s volume control to control the system s volume. You may need to make a minor adjustment to the MS-8 s System Volume setting to allow you to use more of the range in the head unit's volume control.</p> <p>If you hear distortion when the head unit s volume control is at higher settings, increase the MS-8 s System Volume to compensate. This change will let you keep the head unit s volume control within a lower (more distortion-free) portion of its range.</p>
	The MS-8 s Bass Control and/or Graphic EQ bass bands are set with too much boost, combined with a high System Volume setting.	Reduce the Bass Control and/or Graphic EQ boost levels. We recommend never combining high levels of Graphic EQ bass-band boost with high Bass Control boost.

SOUND		
Symptom	Possible Cause	Solution
The center speaker seems too loud when you're listening to news, sports or talk radio stations.	The MS-8's Logic 7 processing is (by design) sending all mono information to the center speaker.	Use the MS-8's System Levels screen to reduce the center speaker's level until it sounds correct to you. Then save the settings as one of the MS-8's Favorite settings so you can recall it whenever you listen to this type of station. See <i>Audio Controls Menu</i> , on page 36, and <i>Favorites Menu</i> , on page 39.
The sound always has too much or too little bass or treble.	The MS-8's Tone Controls and/or Graphic EQ are mis-adjusted.	Use the MS-8's Tone Controls and/or Graphic EQ screens to return all controls to their center positions. See <i>Audio Controls Menu</i> , on page 36.
Music is dull, lifeless and confined-sounding, with poor stereo imaging.	The MS-8's Logic 7 and digital signal processing (DSP) are defeated.	Use the MS-8's Audio Controls menu to activate Logic 7 and DSP. See , on page 36.
	The MS-8's System Volume was set at too high a level during the acoustic-calibration process.	Perform the acoustic-measurement portion of the calibration/setup process again, with the MS-8's System Volume set at -20dB. See <i>Acoustic Calibration</i> , on page 32.

ERROR MESSAGES ON DISPLAY		
Symptom	Possible Cause	Solution
MS-8 Has Overheated	There is insufficient cooling air around the main unit.	Re-install the main unit in a less confined area that will allow cooling air to circulate around the unit. See <i>Choosing a Location for the Main Unit</i> , on page 17.
No DSP Response	There has been a possible electrostatic discharge within the main unit.	If the message displays only once and the MS-8 resets without incident, no further involvement is necessary. If the message displays often, contact JBL Technical Support at 516.255.4JBL (4525).
Voltage Too High or Voltage Too Low	The vehicle's electrical system may be malfunctioning.	If the message displays only once and the MS-8 resets without incident, no further involvement is necessary. If the message displays often, contact your vehicle's dealer or mechanic.
MISCELLANEOUS		
Symptom	Possible Cause	Solution
The display is hard to read.	The Brightness and/or Contrast controls are not properly adjusted.	Use the MS-8's Brightness and Contrast screens to adjust the display for better viewing. See <i>System Settings Menu</i> , on page 40.

SPECIFICATIONS

Power Output:	20W x 8 channels @ 4 ohms
Maximum Output Power:	30W x 8 channels @ 2 ohms
Frequency Response:	20Hz 20kHz
Signal-to-Noise Ratio (Line Input to Line Output):	>90dB
Signal-to-Noise Ratio (Line Input to Speaker Output):	>85dB
Maximum Input Voltage (Speaker-Level Input):	15V
Maximum Input Voltage (Line Input):	2.8V
Maximum Output Voltage (Line Output):	2.8V
Maximum Current Draw:	16A
Standby Current Draw:	<0.01A
Display LCD Screen:	128 x 64 pixels
Power Requirement:	12V DC, negative ground
Main Unit Dimensions (L x W x H):	11-1/2" x 7-3/8" x 2-1/8" (293mm x 187mm x 55mm)
Display Unit Dimensions (H x W x D, including stand):	3-1/8" x 3-3/8" x 2-7/16" (79mm x 86mm x 62mm)
Weight:	Main unit – 6.4 lb (2.9kg) Display unit – 2.8 oz (80g) Remote control – 1.4 oz (40g)

130.com.ua

© 2010 Harman International Industries, Incorporated. All rights reserved. JBL and Logic 7 are trademarks of Harman International Industries, Incorporated, registered in the United States and/or other countries. Dolby and Pro Logic are registered trademarks of Dolby Laboratories. iPod is a trademark of Apple Inc., registered in the U.S. and other countries. iPod is not included. Velcro is a registered trademark of Velcro Industries B.V. Features, specifications and appearance are subject to change without notice.
www.jbl.com

H Harman International

Harman Consumer, Inc.
8500 Balboa Boulevard
Northridge, CA 91329 USA