



PHONES

0 (800) 800 130
(050) 462 0 130
(063) 462 0 130
(067) 462 0 130

130
COM.UA

Internet store of
autogoods



SKYPE

km-130

CAR RECEIVERS — Receivers • Media receivers and stations • Native receivers • CD/DVD changers • FM-modulators/USB adapters • Flash memory • Facia plates and adapters • Antennas • Accessories |
CAR AUDIO — Car audio speakers • Amplifiers • Subwoofers • Processors • Crossovers • Headphones • Accessories | TRIP COMPUTERS — Universal computers • Model computers • Accessories |
GPS NAVIGATORS — Portable GPS • Built-in GPS • GPS modules • GPS trackers • Antennas for GPS navigators • Accessories | VIDEO — DVR • TV sets and monitors • Car TV tuners • Cameras • Videomodules
• Transcoders • Car TV antennas • Accessories | SECURITY SYSTEMS — Car alarms • Bike alarms • Mechanical blockers • Immobilizers • Sensors • Accessories | OPTIC AND LIGHT — Xenon • Bixenon • Lamps
• LED • Stroboscopes • Optic and Headlights • Washers • Light, rain sensors • Accessories | PARKTRONICS AND MIRRORS — Rear parktronic • Front parktronic • Combined parktronic • Rear-view mirrors
• Accessories | HEATING AND COOLING — Seat heaters • Mirrors heaters • Screen-wipers heaters • Engine heaters • Auto-refrigerators • Air conditioning units • Accessories | TUNING — Vibro-isolation
• Noise-isolation • Tint films • Accessories | ACCESSORIES — Radar-detectors • Handsfree, Bluetooth • Windowlifters • Compressors • Beeps, loudspeakers • Measuring instruments • Cleaners • Car seats
• Miscellaneous | MOUNTING — Installation kits • Upholstery • Grilles • Tubes • Cable and wire • Tools • Miscellaneous | POWER — Batteries • Converters • Start-charging equipment • Capacitors
• Accessories | MARINE AUDIO AND ELECTRONICS — Marine receivers • Marine audio speakers • Marine subwoofers • Marine amplifiers • Accessories | CAR CARE PRODUCTS — Additives • Washer fluid •
Care accessories • Car polish • Flavors • Adhesives and sealants | LIQUID AND OIL — Motor oil • Transmission oil • Brake fluid • Antifreeze • Technical lubricant



In store "130" you can find and buy almost all necessary goods for your auto in Kyiv and other cities, delivery by ground and postal services. Our experienced consultants will provide you with exhaustive information and help you to chose the very particular thing. We are waiting for you at the address

<https://130.com.ua>

130.COMMERCIALSTREET

EDGE

& B E Y O N D

AMPLIFIER
USER GUIDE

INTRODUCTION

This instruction manual is for your safety and must be adhered to at all times. Please read and ensure that you fully understand the installation and set up procedures as explained. If you are unclear on the installation or set up of your EDGE speakers please contact your nearest authorised EDGE dealer.

WARNING

DO NOT EXPOSE THIS PRODUCT TO DAMP OR MOISTURE - doing so may result in fire, shock or damage to the product.

BEFORE WIRING DISCONNECT THE CABLE FROM THE POSITIVE BATTERY TERMINAL - failure to do so may result in electric shock or injury.

ENSURE GOOD AND CORRECT CONNECTIONS - failure to make the correct connections may result in fire or damage to the product.

DO NOT USE ANY FUNCTIONS OF THIS EQUIPMENT THAT MAY TAKE YOUR CONCENTRATION AWAY FROM DRIVING YOUR VEHICLE - do not set up your amplifier whilst driving, doing so may result in an accident. For prolonged setting up, make sure that your vehicle is stationary and in a safe location.

KEEP THE VOLUME AT A LEVEL SO YOU CAN STILL HEAR OUTSIDE NOISE - failure to do this may result in an accident. EDGE equipment is capable of producing sound levels that can permanently damage your hearing. EDGE recommends caution when listening at high volume. For safe and enjoyable listening the sound should be comfortable and clear without distortion.

CAUTION

Never connect any speaker lead to the car chassis. This can cause severe damage to your speaker /car radio /amplifier.

Before drilling or cutting any holes, investigate the layout of your vehicle thoroughly.

Use caution when working near the fuel / hydraulic lines and electrical wiring.

Observe the correct polarity when wiring, improper phasing may cause a loss of bass response.

Ensure that no moving parts catch on the speaker or grill (e.g. window or door handles, or window glass inside the door)

Mounting Guidelines

Your EDGE amplifier is designed with a swift installation routine in mind. Please mount the amplifier in a dry location on a solid surface. NEVER mount the amplifier upside down, this will cause the amplifier to over heat and will eventually damage the amplifier. Before fixing the amplifier in place please ensure that there is sufficient air flow around the exterior of the casing, at least two inches is sufficient.

Connections

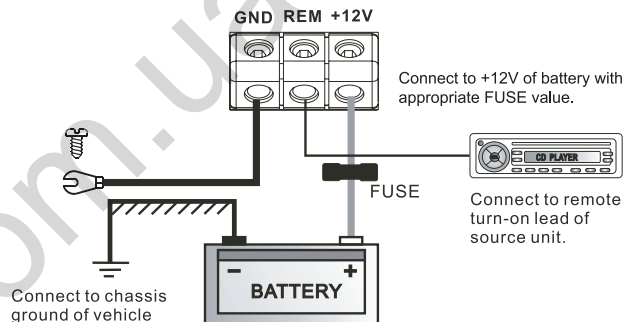

Power / Ground Cable

- The correct gauge cable should be used for both the power and the ground connections to the amplifier.
- The power cable should be taken directly from the battery. Rubber grommets should be used when passing through any bulkheads to prevent the cable from becoming chaffed or cut.
- The correct size of fuse must be fitted within 18" of the battery and before the cable passes through the bulk head
- It is vital that a fuse / circuit breaker (of at least equal value to the one fitted on the amplifier) is placed inline with the power cable and is no further than eighteen inches away from the battery.
- Please ensure that the fuse is not fitted until the entire installation procedure is complete.
- The two tables below are to help you decide on what cable is correct for you. The first enables you to select the size of cable depending on the length required. The second will help you convert the cable size from American Wire Gauge to Metric if you need to.
- The amplifier ground should be connected directly to the chassis of the vehicle, to bare metal.
- The cable length should be kept to an absolute minimum.

ED7400

- Minimum 10 AWG power / ground cable should be used

ED7800 / 71200 / 71600

- Minimum 8 AWG power / ground cable should be used

ED72500

- Minimum 4 AWG power / ground cable should be used

Remote Turn On

- A minimum of 18 gauge cable should be used for this connection.
- The cable should be run with exactly the same care and attention as the power cable and taken back to the source (headunit) and joined to the remote cable provided.
- If the source (headunit) does not have a remote turn on cable then a 12v supply should be used. This will require a switch to be fitted inline to enable the amplifier to be turned on and off. Remember that if this switch is left on you will flatten the car battery.

RCA Cables

- Depending on the model number of your amplifier and the number of speakers you wish to power you will have to run either one or two RCA cables from the source to the amplifier.
- Please take extra care when running these cables from the source to the amplifier. Ensure that they are placed away from all items that can generate any interference, wiring harnesses etc.
- It is recommended that the RCA cables should be run on opposite sides of the car to the previously installed power cables if possible, to avoid the cable picking up interference.

Limited Warranty

All EDGE goods are covered by a full 12 months manufacturers warranty. Valid from the date of the original receipt and proof of purchase. In order to validate this warranty, the warranty card should be returned to EDGE within seven days of the original purchase date. The original receipt and packaging should also be kept for this 12 month period.

If at any stage during the warranty period you have a problem with the product then it should be returned to the point of purchase in its original packaging, complete and with no items missing.

If the store is unable to fix the product it may have to be returned to EDGE this process takes around 7 working days.

A full description of EDGE's warranty information can be found on our website:

www.edgearaudio.com/warranty

A written version can also be obtained from
EDGE warranty department
PO Box 11000
B75 7WG

Copyright

All content included in this manual such as text, graphics, logos, icons, images data, the selection and arrangement thereof, are the property of EDGE Audio (herein referred to as "EDGE", "us" or "we") and its affiliate or their content and technology providers, and are protected by United Kingdom and International copyright laws. All rights reserved.

Trademarks

EDGE ED2™, EDGE ED3™, EDGE ED4™, EDGE ED5™, EDGE ED6™, EDGE ED7™, EDGE Street™ and EDGE Loud™ and all stylised representations of product names, or the abbreviations of product names, as logos are all trademarks of EDGE. Graphics and logos are trademarks or trade dress of EDGE Audio or its subsidiaries.

EDGE's trademarks and trade dress may not be used in connection with any product or service that is not EDGE's, in any manner that is likely to cause confusion among customers or in any manner that disparages or discredits EDGE. All other trademarks not owned by EDGE or its subsidiaries that appear in this manual are the property of their respective owners, who may or may not be affiliated with, connected to, or sponsored by EDGE or its subsidiaries.

We reserve the right to make needed changes or improvements to the product and this manual, without informing the customer about this in advance

Model	ED7400	ED7800	ED71600	ED71200	ED72500
Type	2/1 channel	4/3/2 channel	4/3/2 channel	Monoblock	Monoblock
Class	AB	AB	AB	D	D
4 ohm stereo	2 x 80 watts RMS	4 x 80 watts RMS	4 x 140 watts RMS	N/A	N/A
2 ohm stereo	2 x 100 watts RMS	4 x 100 watts RMS	4 x 200 watts RMS	N/A	N/A
4 ohm mono	1 x 200 watts RMS	2 x 200 watts RMS	2 x 400 watts RMS	1 x 200 watts RMS	1 x 400 watts RMS
2 ohm mono	N/A	N/A	N/A	1 x 400 watts RMS	1 x 800 watts RMS
1 ohm mono	N/A	N/A	N/A	1 x 600 watts RMS	1 x 1250 watts RMS
Max power	400 watts	800 watts	1600 watts	1200 watts	2500 watts
Freq response	20Hz – 20KHz	20Hz – 20KHz	20Hz – 20KHz	20Hz – 300Hz	20 Hz – 300Hz
Height	66mm	66mm	66mm	66mm	66mm
Width	282mm	332mm	452mm	325mm	416 mm
Depth	245mm	245mm	245mm	245mm	245mm

Terminals and Controls ED7400

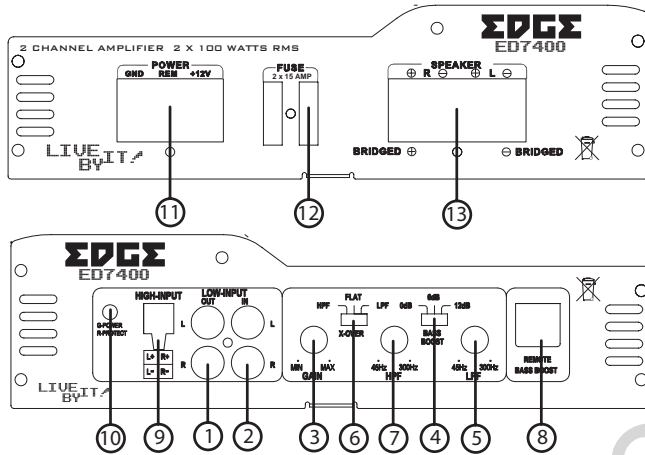

1. Low Level Output

A daisy chain output For connection to another amplifier with a low level input using only a single RCA output from the source (headunit).

2. Low Level Input

For connection to any source (headunit) with a low level output. This is your RCA output from the source (headunit)

3. Gain Control

Used to match the input signal of the source to the amplifier. See the setup section for more details.

4. Bass Boost Switch

To provide up to an extra +12 dB of bass boost at 45 Hz. Use this boost to increase bass output from the amplifier.

5. Low Pass Crossover Control

The control is used to select the low pass filter frequency. The frequency ranges are from 45 Hz to 300 Hz.

6. Crossover Control Switch

This switch is used to select high pass, low pass or flat (no crossover) operation for the amplifier speaker outputs.

7. High Pass Crossover Control

The control is used to select the High pass filter frequency. The frequency ranges are from 45 Hz to 300Hz.

8. Bass Boost Remote Input Jack

Use to plug in the remote bass controller. (Optional) see back

9. High Level Input

To be used when no RCA's are available. Use the provided loom to connect to closest speakers. The loom connector will only fit one way around. Once plugged in you should connect the wires as below:

Left Positive - White Right Positive - Grey Left Negative - White / Black
Right Negative - Grey / Black

10. Indicator LED

When the amplifier is operating correctly the LED will show as green. When the amplifier is in protection mode the LED will show as red.

11. Power Connections

Power connections. See Connections section for details on correct connections.

12. Fuses

Please ensure the following fuse rating is used when replacing fuses: 15 amp x 2

13. Speaker Terminal Output

For connection to the speakers. See Application section for wiring examples.

Terminals and Controls ED7800

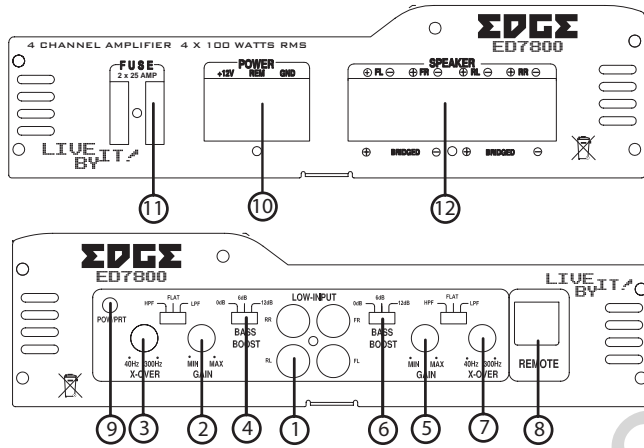

1. Low Level Input

For connection to any source (headunit) with a low level output. This is your RCA output from the source (headunit).

2. Rear Gain Control

Used to match the input signal of the source to the amplifier. See the setup section for more details.

3. Rear Crossover Control

The switch is used to select between low pass / high pass filter or no filter at all on the front channels. The frequency ranges on the low pass filter are from 40 Hz to 300 Hz. The frequency ranges on the high pass filter are from 40 Hz to 300hz.

4. Rear Bass Boost Switch

To provide up to an extra +12 dB of bass boost at 45 Hz. Use this boost to increase bass output from the amplifier.

5. Front Gain Control

Used to match the input signal of the source to the amplifier. See the setup section for more details.

6. Front Bass Boost Switch

To provide up to an extra +12 dB of bass boost at 45 Hz. Use this boost to increase bass output from the amplifier.

7. Front Crossover Control

The switch is used to select between low pass / high pass filter or no filter at all on the rear channels. The frequency ranges on the low pass filter are from 40 Hz to 300 Hz. The frequency ranges on the high pass filter are from 40 Hz to 300hz.

8. Front Bass Boost Remote Input Jack

Use to plug in the remote bass controller. (optional)

9. Indicator LED

When the amplifier is operating correctly the LED will show as green
When the amplifier is in protection mode the LED will show as red.

10. Power Connections

Power connections. See Connections section for details on correct connections.

11. Fuses

Please ensure the following fuse rating is used when replacing fuses: 25 amp x 2

12. Speaker Terminal Output

For connection to the speakers. See Application section for wiring examples.

Terminals and Controls ED71600

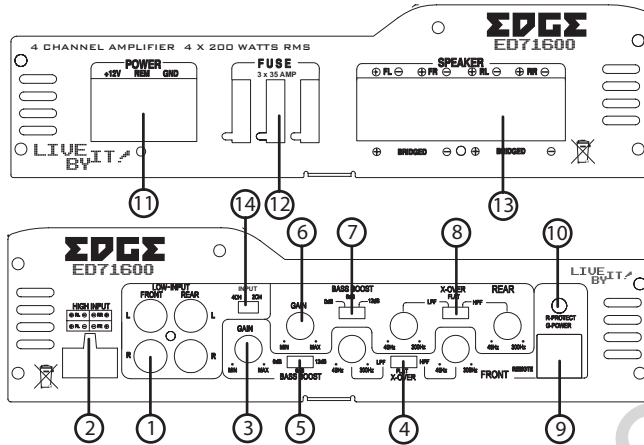

1. Low Level Input

For connection to any source (headunit) with a low level output. This is your RCA output from the source (headunit).

2. High Level Input

To be used when no RCA's are available. Use the provided loom to connect to closest speakers. The loom connector will only fit one way around. Once plugged in you should connect the wires as below:

Front Speakers

Left Positive - Green
Left Negative - Green / Black

Right Positive - Purple
Right Negative - Purple / Black

Rear Speakers

Left Positive - White
Left Negative - White / Black

Right Positive - Grey
Left Negative - Grey / Black

3. Front Gain Control

Used to match the input signal of the source to the amplifier. See the setup section for more details.

4. Front Crossover Control

The switch is used to select between low pass / high pass filter or no filter at all on the front channels. The frequency ranges on the low pass filter are from 45 Hz to 300 Hz. The frequency ranges on the high pass filter are from 45 Hz to 300 Hz.

5. Front Bass Boost Switch

To provide up to an extra +12 dB of bass boost at 45 Hz. Use this boost to increase bass output from the amplifier.

6. Rear Gain Control

Used to match the input signal of the source to the amplifier. See the setup section for more details.

7. Rear Bass Boost Switch

To provide up to an extra +12 dB of bass boost at 45 Hz. Use this boost to increase bass output from the amplifier.

8. Rear Crossover Control Switch

The switch is used to select between low pass / high pass filter or no filter at all on the rear channels. The frequency ranges on the low pass filter are from 45 Hz to 300 Hz. The frequency ranges on the high pass filter are from 45 Hz to 300 Hz.

9. Front Bass Boost Remote Input Jack

Use to plug in the remote bass controller. (optional)

10. Indicator LED

When the amplifier is operating correctly the LED will show as green.
When the amplifier is in protection mode the LED will show as red.

11. Power Connections

Power connections. See Connections section for details on correct connections.

12. Fuses

Please ensure the following fuse rating is used when replacing fuses: 35 amp x 3

13. Speaker Terminal Output

For connection to the speakers. See Application section for wiring examples.

14. Input Mode Select Switch

Allows 4 channels to be driven from a single pair of RCA leads

Terminals and Controls ED71200

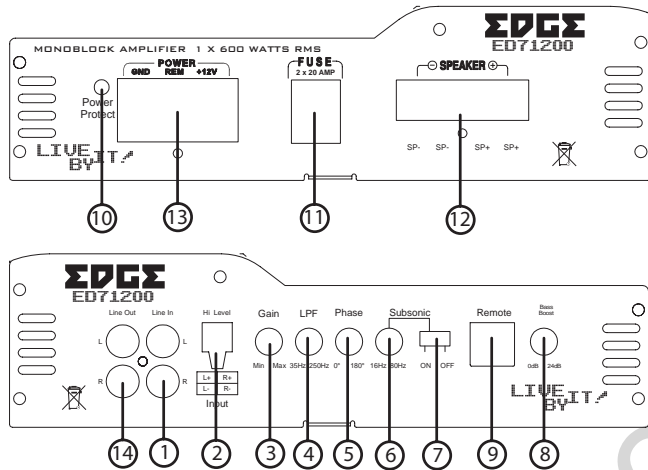

1. Low Level Input

For connection to any source (head unit) with a low level output. This is your RCA output from the source (headunit).

2. High Level Input

To be used when no RCA's are available. Use the provided loom to connect to closest speakers. The loom connector will only fit one way around. Once plugged in you should connect the wires as below:

Left Positive - Brown Right Positive - Black Left Negative - Blue Right Negative - Green

3. Gain Control

Used to match the input signal of the source to the amplifier. See the setup section for more details.

4. Low Pass Filter Control

Low pass frequency control. The frequency ranges from 35 Hz to 250 Hz.

5. Phase Control

Can be used to alter the phase of the subwoofer from 0 - 180 degrees.

IE: the speaker output can be In phase or out of phase with the other speakers in the vehicle. For best results rotate the dial between the two settings to determine the best sound.

6. Subsonic Filter Control

This is used to filter out unwanted amplifier output to the subwoofer. Effectively this will filter out all the frequencies up to the crossover point set with the control. The range is from 16 Hz to 80 Hz. Frequencies of 80 Hz and below cause the subwoofer to work hard, some subwoofers can easily be damaged when playing very low frequencies. Using the subsonic filter allows less distortion, delivers frequencies better suited to the subwoofer prolonging its life.

7. Subsonic Filter Switch

Used to turn the filter on or off.

8. Bass Boost Switch

To provide up to an extra +18 dB of bass boost at 45 Hz. Use this boost to increase bass output from the amplifier.

9. Bass Remote Input Jack

Use to plug in the remote bass controller.

10. Indicator LED

When the amplifier is operating correctly the LED will show as green. When the amplifier is in protection mode the LED will show as red.

11. Fuses

Please ensure the following fuse rating is used when replacing fuses:
20 amp x 2

12. Speaker Terminal Output

For connection to the speakers. See Application section for wiring examples.

13. Power Connections

Power connections. See Connections section for details on correct connections.

14. Low Level Output

Daisy chain RCA connection to allow easy addition of another amplifier.

Terminals and Controls ED72500

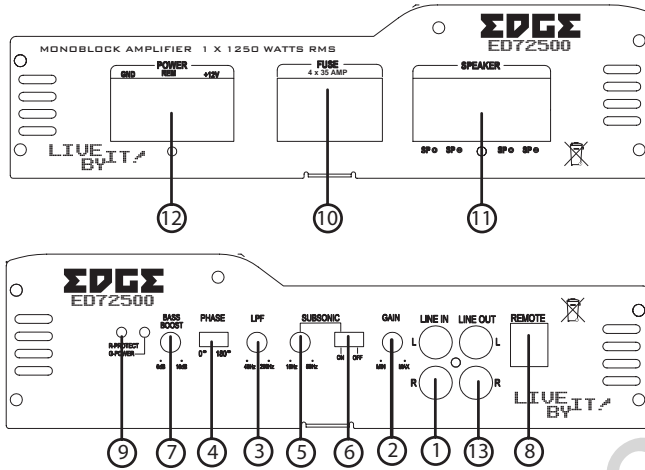

1. Low Level Input

For connection to any source (head unit) with a low level output. This is your RCA output from the source (headunit).

2. Gain Control

Used to match the input signal of the source to the amplifier. See the setup section for more details.

3. Low Pass Filter Control

Low pass frequency control. The frequency ranges from 40 Hz to 250 Hz.

4. Phase Control

Can be used to alter the phase of the subwoofer from 0 - 180 degrees.

IE: the speaker output can be inphase or out of phase with the other speakers in the vehicle. For best results flick between the two settings to determine the best results.

5. Subsonic Filter Control

This is used to filter out unwanted amplifier output to the subwoofer. Effectively this will filter out all the frequencies up to the crossover point set with the control. The range is from 15 Hz to

50 Hz. Frequencies of 80 Hz and below cause the subwoofer to work hard, some subwoofers can easily be damaged when playing very low frequencies. Using the subsonic filter allows less distortion, delivers frequencies better suited to the subwoofer prolonging its life.

6. Subsonic Filter Switch

Used to turn the filter on or off.

7. Bass Boost control

To provide up to an extra +18 dB of bass boost at 45 Hz. Use this boost to increase bass output from the amplifier.

8. Bass Remote Input Jack

Use to plug in the remote bass controller.

9. Indicator LED

When the amplifier is operating correctly the LED will show as green. When the amplifier is in protection mode the LED will show as red.

10. Fuses

Please ensure the following fuse rating is used when replacing fuses:
35 amp x 4

11. Speaker Terminal Output

For connection to the speakers. See Application section for wiring examples.

12. Power Connections

Power connections. See Connections section for details on correct connections.

13. Low Level Output

Daisy chain RCA connection to allow easy addition of another amplifier.

Set Up Section

To correctly set the gain control of the amplifier to match that of the source (headunit) use the following setup routine:

Turn the gain control to minimum on the amplifier.

Ensure the bass boost is set to 0 dB.

On the headunit set all crossovers to flat and both bass and treble to zero.

Turn up the source (headunit) to approx 3/4 volume.

Very slowly turn up the gain on the amplifier until distortion can be heard in any of the speakers or until the volume reaches an uncomfortable listening level when this is reached turn down the gain control slightly.

The gain control is now set.

The setting of the crossover will depend on what kind of speaker you are installing.

For a subwoofer it is recommended that the crossover is set to Low Pass and the frequency is set to match that of the speakers specifications.

For a pair of full range speakers it is recommend that the crossover is set to Flat. The two frequency controls will then have no effect on the amplifiers output and the speaker will receive a full range signal. However, using the high pass crossovers will allow more control of your speakers. By removing the bass (low frequencies) the speakers can perform at higher volumes with less distortion.

Note: The smaller the speaker, the less bass it can handle. Adjust the crossover to get the most and best sound from your speakers. The easiest was to do this is by limiting the amount of bass you feed them

For a pair of speakers with a passive crossover it is recommended that the crossover is set to High Pass and the frequency is set to match that of the speakers specifications.

Note:

By using the crossovers correctly you will not only lengthen the life of your speakers but you will also get better performance from them. To optimise your setup seek the advice of a professional installation engineer or visit your local EDGE audio dealer.

Troubleshooting

- Before removing the amplifier, refer to the list below and follow the suggested procedures.
- Always test the speakers and confirm that they are wired correctly first.
- If in any doubt get help from a qualified auto electrician.

Amplifier Will Not Power Up

- Check for good ground connections. Ensure Ground cable is connected directly to bare metal and not a painted surface.
- Using a multimeter check that remote terminal has at least 10V DC.
- Using a multi meter check that there is battery voltage on the positive terminal.
- Check all fuses.
- Check that the protection light is not illuminated. If it is lit, shut off the amplifier for thirty seconds and then turn it back on.

Protection LED Illuminates When Amplifier Is Powered Up

- Check for shorts on all speakers wires. (IE no speaker wires should be joined together and no speaker wires should be touching the cars chassis)
- The amplifier is designed to shut down automatically when the units temperature goes above 80 degrees. If the amplifier feels very hot then this may be the reason for the amplifier not starting.
- Remove the speaker wires and reset the amplifier. If the protection LED still comes on then the amplifier is faulty. This damage may have been caused by either failure to follow these setup guidelines or abuse.

Amplifier Gets Very Hot

- Check the minimum speaker impedance for the amplifier is correct.
- Check for shorts on all speakers wires. (IE no speaker wires should be joined together and no speaker wires should be touching the cars chassis)
- Check that there is good airflow around the amplifier. In some applications an external fan may be required.

Blown Fuse(s)

- Check both positive supply and ground for shorts.
- Check that the positive wire is connected to the positive terminal on the amplifier.
- Check that the negative wire is connected to the ground terminal on the amplifier.
- Ensure that the correct rated fuse is fitted

Distorted Sound

- Check the gain control is not set at too high a level. If the speakers sound distorted turn the down the gain until the sound is clear.
- Check that all crossover frequencies are correct. See setup section for more details.
- Check for shorts on all speaker wires.
- Check all speakers are wired correctly. With the correct polarity being observed on each connection.

Applications

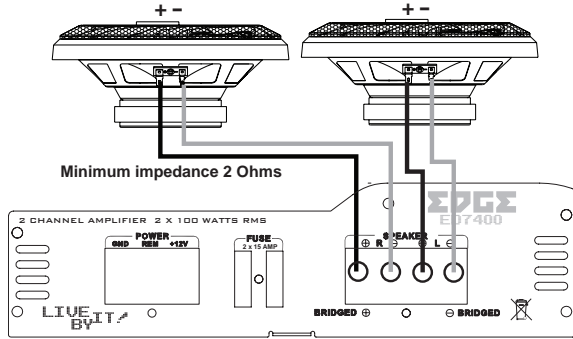

ED7400 in 2 channel configuration connected to a pair of ED209 speakers

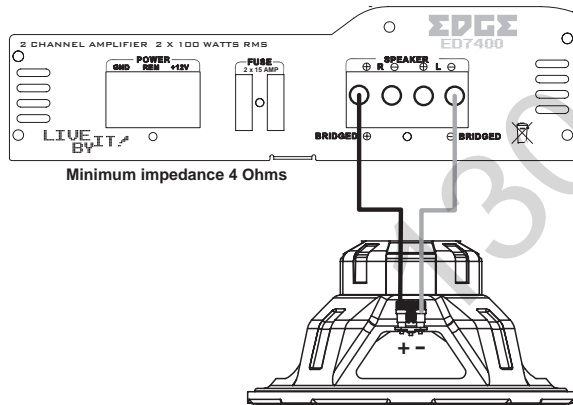

ED7400 in bridged configuration connected to an ED512 subwoofer

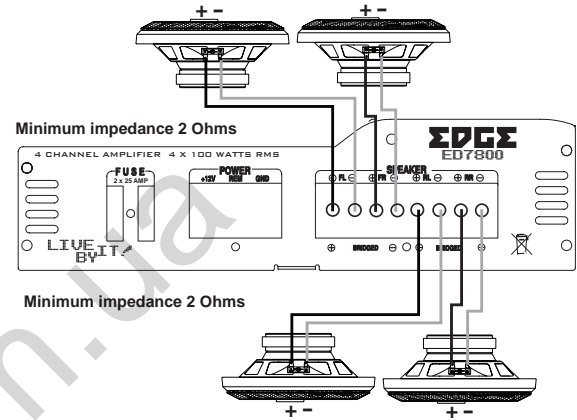

ED7800 / 71600 in 4 channel configuration connected to 2 pairs of ED209 speakers

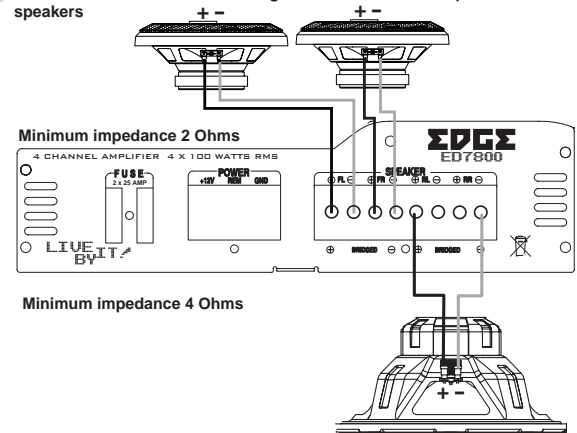

ED7800 / 71600 in 3 channel configuration connected to a pair of ED209 speakers and an ED512 subwoofer

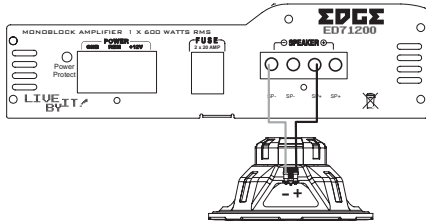

ED71200
connected in mono
configuration to an
ED512 subwoofer
at 4 ohms

Minimum
impedance 1 Ohms

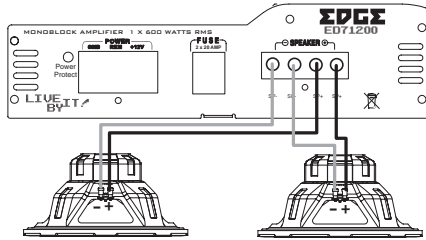

ED71200
connected in mono
configuration a
pair of ED512
subwoofers at 2
ohms

Minimum
Impedance 1 Ohms

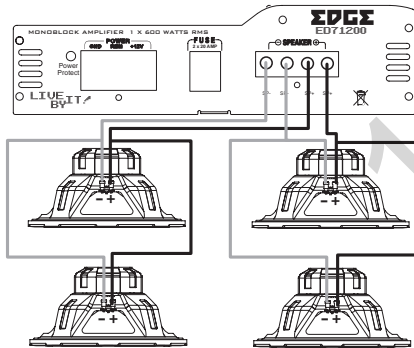

ED71200
connected in mono
configuration to 4
ED512 subwoofers
at 1 ohms

Minimum
Impedance 1 Ohms

ED72500
connected in mono
configuration to an
ED512 subwoofer
at 4 ohms

Minimum
impedance 1 Ohms

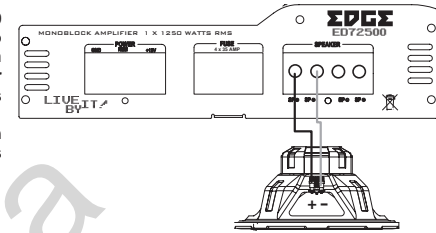

ED72500
connected in mono
configuration a
pair of ED512
subwoofers at 2
ohms

Minimum
Impedance 1 Ohms

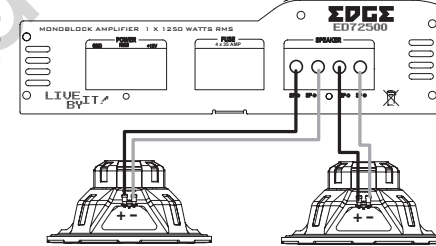

ED72500
connected in mono
configuration to 4
ED512 subwoofers
at 1 ohms

Minimum
Impedance 1 Ohms

