



PHONES

0 (800) 800 130  
(050) 462 0 130  
(063) 462 0 130  
(067) 462 0 130

130  
COM.UA

Internet store of  
autogoods



SKYPE

km-130

CAR RECEIVERS — Receivers • Media receivers and stations • Native receivers • CD/DVD changers • FM-modulators/USB adapters • Flash memory • Facia plates and adapters • Antennas • Accessories |  
 CAR AUDIO — Car audio speakers • Amplifiers • Subwoofers • Processors • Crossovers • Headphones • Accessories | TRIP COMPUTERS — Universal computers • Model computers • Accessories |  
 GPS NAVIGATORS — Portable GPS • Built-in GPS • GPS modules • GPS trackers • Antennas for GPS navigators • Accessories | VIDEO — DVR • TV sets and monitors • Car TV tuners • Cameras • Videomodules  
 • Transcoders • Car TV antennas • Accessories | SECURITY SYSTEMS — Car alarms • Bike alarms • Mechanical blockers • Immobilizers • Sensors • Accessories | OPTIC AND LIGHT — Xenon • Bixenon • Lamps  
 • LED • Stroboscopes • Optic and Headlights • Washers • Light, rain sensors • Accessories | PARKTRONICS AND MIRRORS — Rear parktronic • Front parktronic • Combined parktronic • Rear-view mirrors  
 • Accessories | HEATING AND COOLING — Seat heaters • Mirrors heaters • Screen-wipers heaters • Engine heaters • Auto-refrigerators • Air conditioning units • Accessories | TUNING — Vibro-isolation  
 • Noise-isolation • Tint films • Accessories | ACCESSORIES — Radar-detectors • Handsfree, Bluetooth • Windowlifters • Compressors • Beeps, loudspeakers • Measuring instruments • Cleaners • Car seats  
 • Miscellaneous | MOUNTING — Installation kits • Upholstery • Grilles • Tubes • Cable and wire • Tools • Miscellaneous | POWER — Batteries • Converters • Start-charging equipment • Capacitors  
 • Accessories | MARINE AUDIO AND ELECTRONICS — Marine receivers • Marine audio speakers • Marine subwoofers • Marine amplifiers • Accessories | CAR CARE PRODUCTS — Additives • Washer fluid •  
 Care accessories • Car polish • Flavors • Adhesives and sealants | LIQUID AND OIL — Motor oil • Transmission oil • Brake fluid • Antifreeze • Technical lubricant



In store "130" you can find and buy almost all necessary goods for your auto in Kyiv and other cities, delivery by ground and postal services. Our experienced consultants will provide you with exhaustive information and help you to chose the very particular thing. We are waiting for you at the address

<https://130.com.ua>



**Robert Bosch Power Tools GmbH**

70538 Stuttgart  
GERMANY

[www.bosch-pt.com](http://www.bosch-pt.com)

1 609 92A 5KX (2017.04) PS / 508



1 609 92A 5KX

# GTM 12 JL Professional

 **BOSCH**

<b>de</b> Originalbetriebsanleitung	<b>tr</b> Orijinal işletme talimatı	<b>mk</b> Оригинално упатство за работа
<b>en</b> Original instructions	<b>pl</b> Instrukcja oryginalna	<b>sr</b> Originalno uputstvo za rad
<b>fr</b> Notice originale	<b>cs</b> Původní návod k používání	<b>sl</b> Izvirna navodila
<b>es</b> Manual original	<b>sk</b> Pôvodný návod na použitie	<b>hr</b> Originalne upute za rad
<b>pt</b> Manual original	<b>hu</b> Eredeti használati utasítás	<b>et</b> Algupärane kasutusjuhend
<b>it</b> Istruzioni originali	<b>ru</b> Оригинальное руководство по эксплуатации	<b>lv</b> Instrukcijas oriģinālvalodā
<b>nl</b> Oorspronkelijke gebruiksaanwijzing	<b>uk</b> Оригінальна інструкція з експлуатації	<b>lt</b> Originali instrukcija
<b>da</b> Original brugsanvisning	<b>kk</b> Пайдалану нұсқаулығының түпнұсқасы	<b>ko</b> 사용 설명서 원본
<b>sv</b> Bruksanvisning i original	<b>ro</b> Instrucțiuni originale	<b>ar</b> تعليمات التشغيل الأصلية
<b>fi</b> Alkuperäiset ohjeet	<b>bg</b> Оригинална инструкция	<b>fa</b> دفترچه راهنمای اصلی
<b>el</b> Πρωτότυπο οδηγιών χρήσης		

Deutsch .....	Seite	21
English .....	Page	37
Français .....	Page	51
Español .....	Página	66
Português.....	Página	82
Italiano .....	Página	98
Nederlands .....	Página	114
Dansk .....	Side	129
Svenska .....	Sida	143
Norsk .....	Side	157
Suomi .....	Sivu	171
Ελληνικά .....	Σελίδα	185
Türkçe .....	Sayfa	201
Polski .....	Strona	216
Česky .....	Strana	232
Slovensky.....	Strana	246
Magyar .....	Oldal	261
Русский .....	Страница	276
Українська.....	Сторінка	293
Қазақша.....	Бет	309
Română .....	Pagina	324
Български .....	Страница	339
Македонски .....	Страна	356
Srpski .....	Strana	372
Slovensko .....	Stran	386
Hrvatski .....	Stranica	400
Eesti .....	Lehekülj	414
Latviešu .....	Lappuse	428
Lietuviškai .....	Puslapis	444
한국어 .....	페이지	458
عربي .....	صفحة	487
فارسی .....	صفحه	503

CE .....

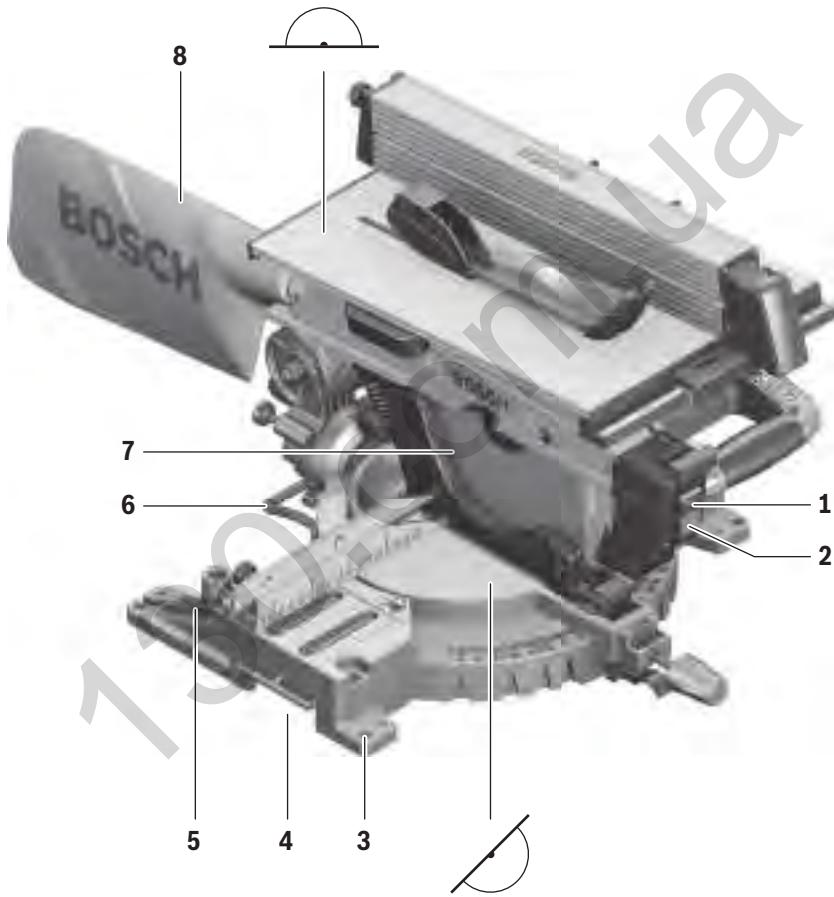

**GTM 12 JL**

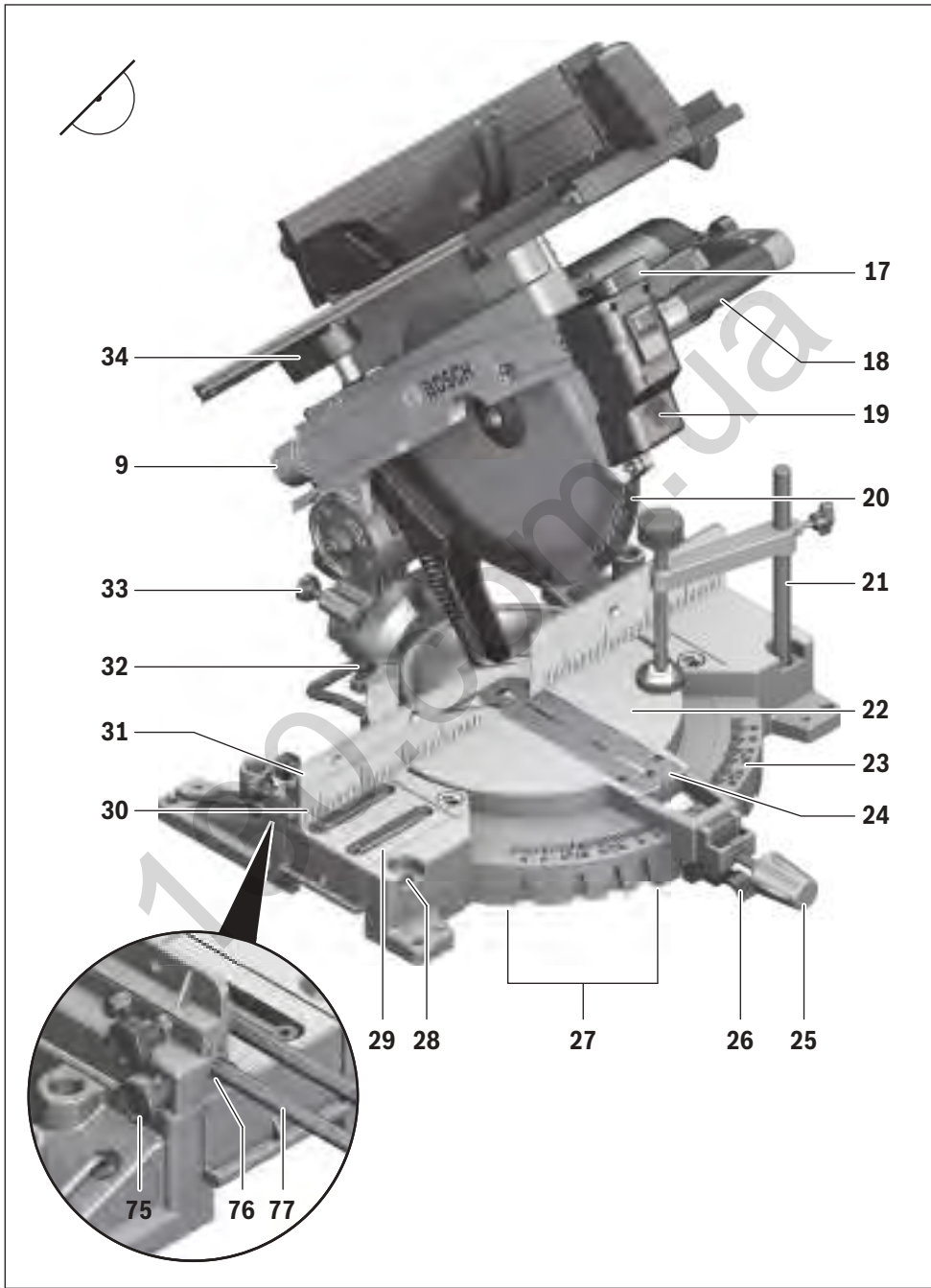



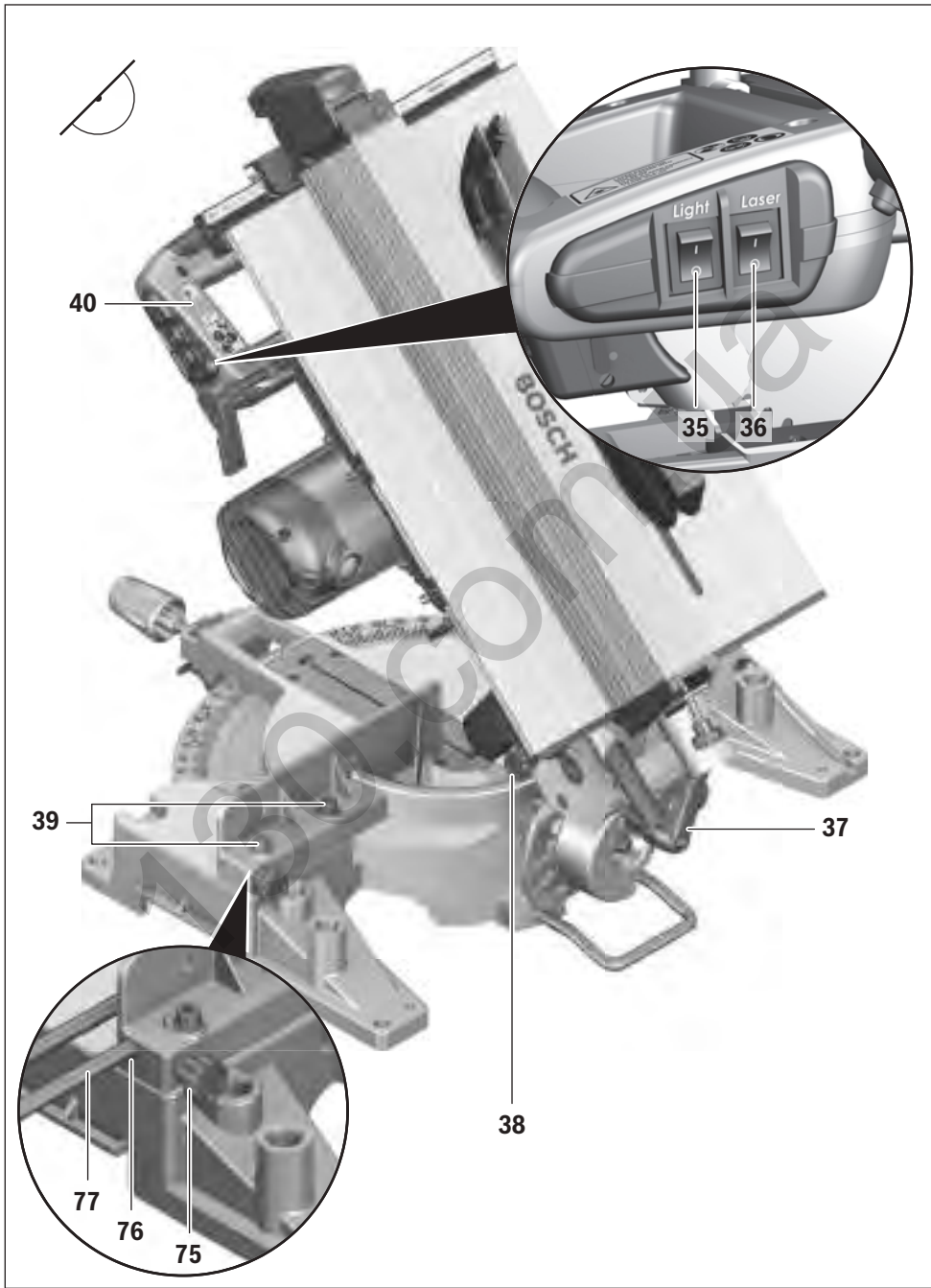

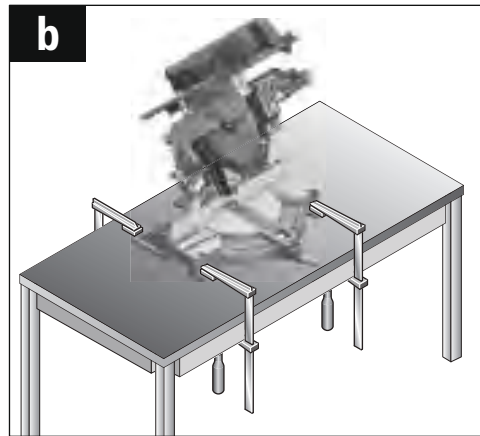
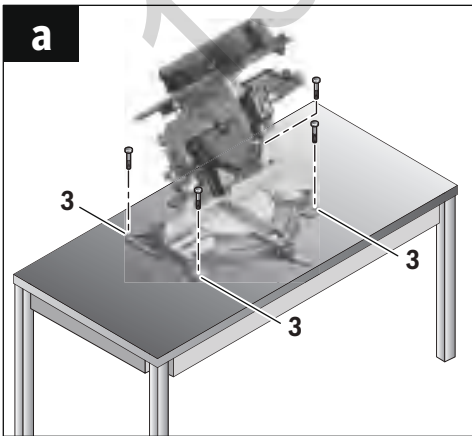
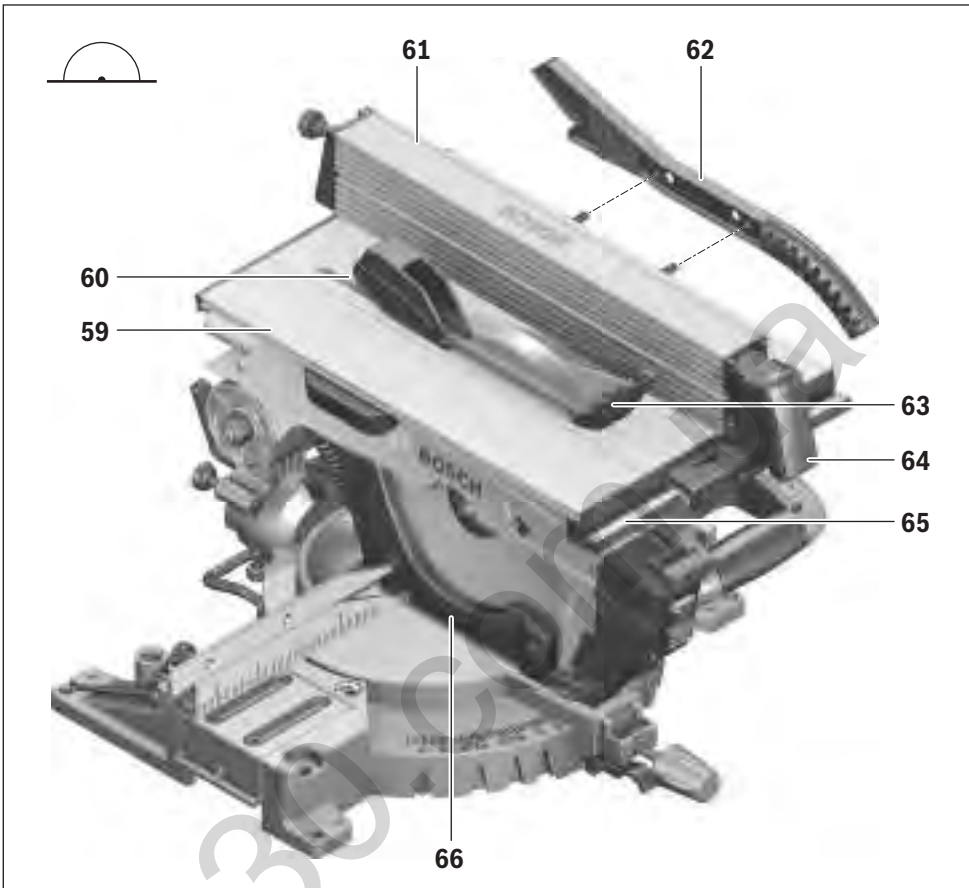

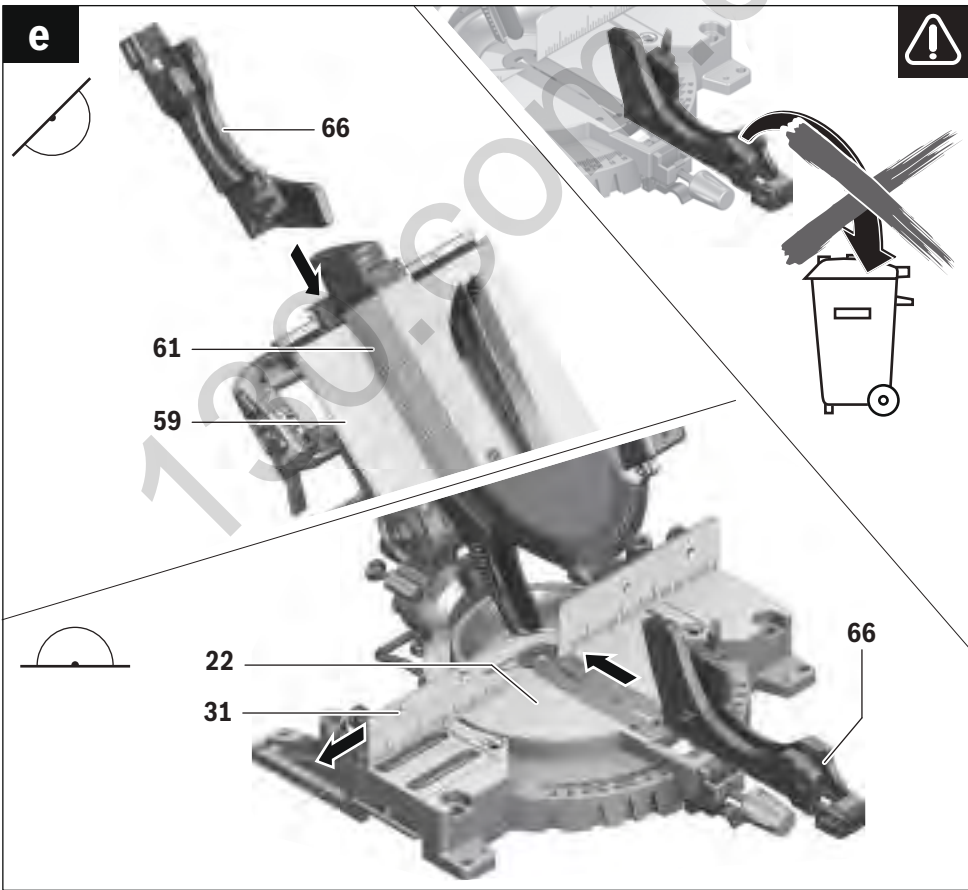
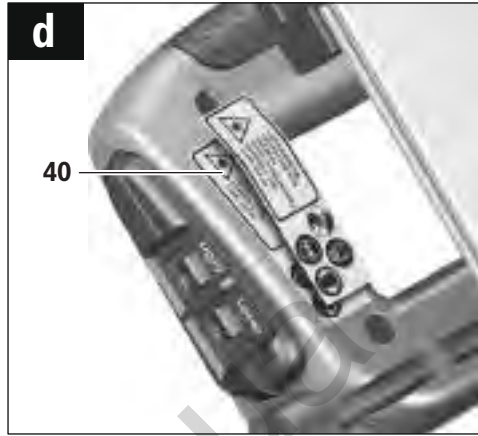
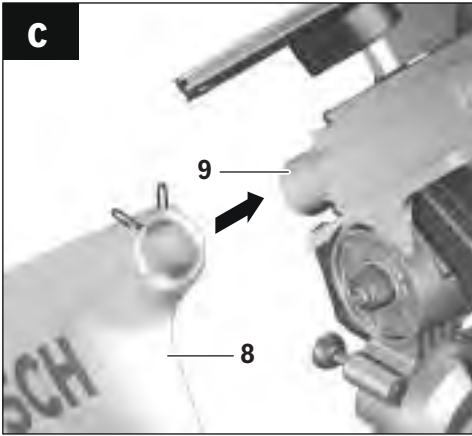



8 |

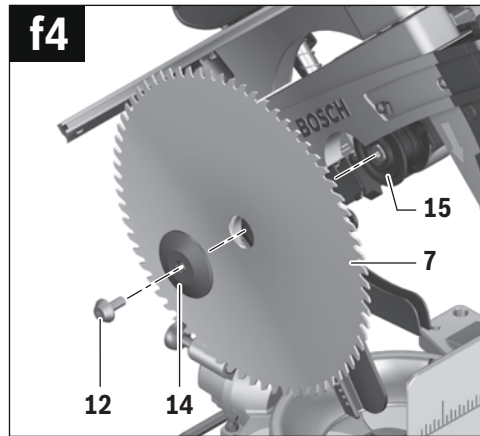
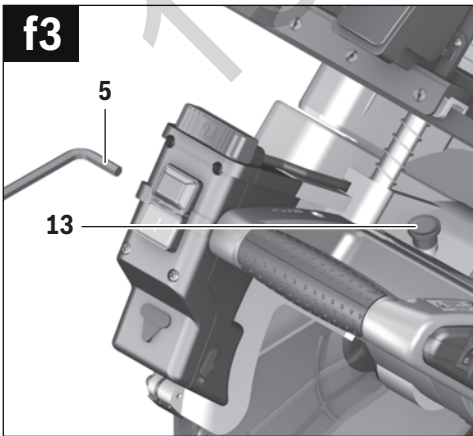
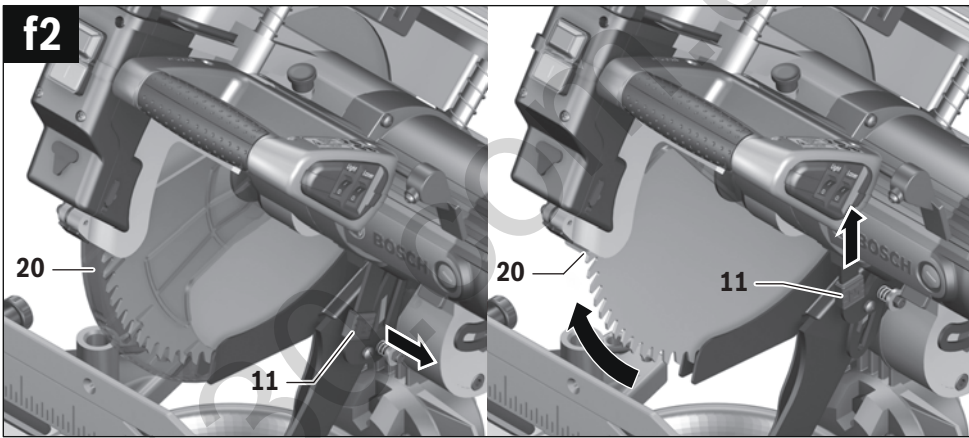
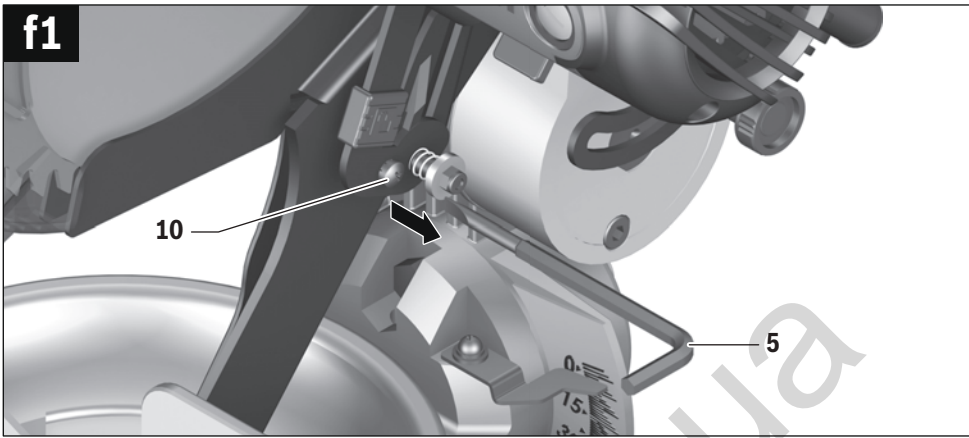

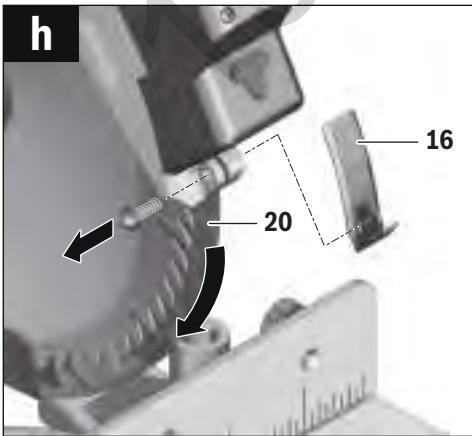
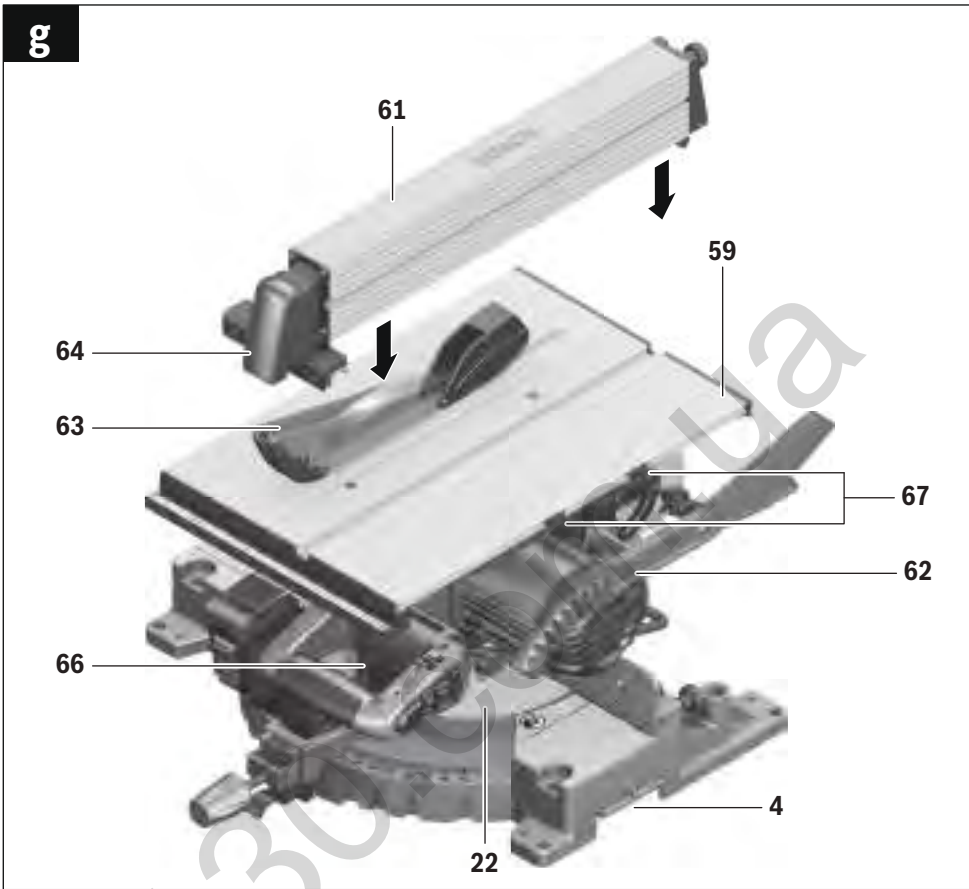

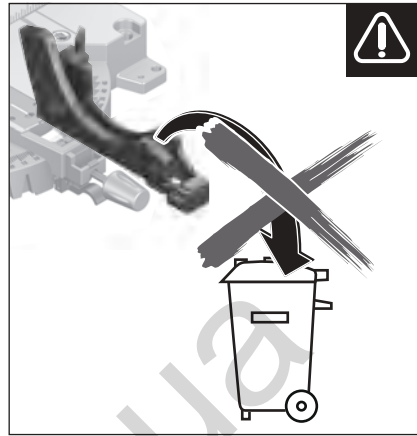

**A**

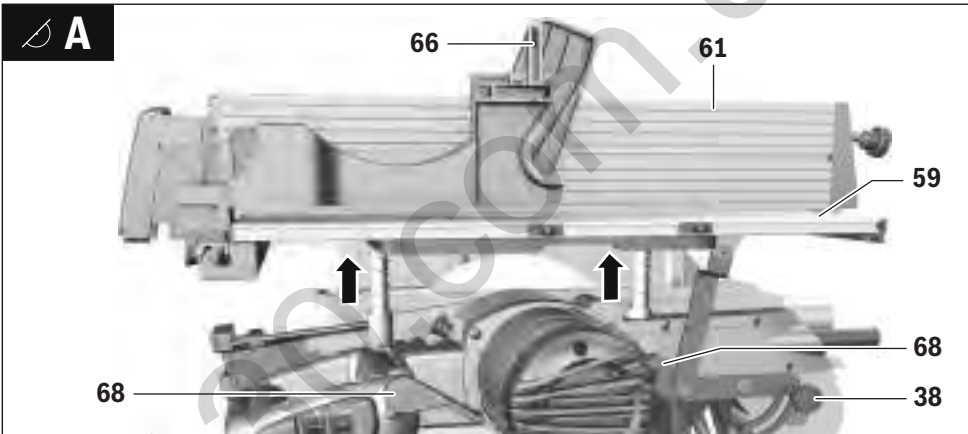

**B**

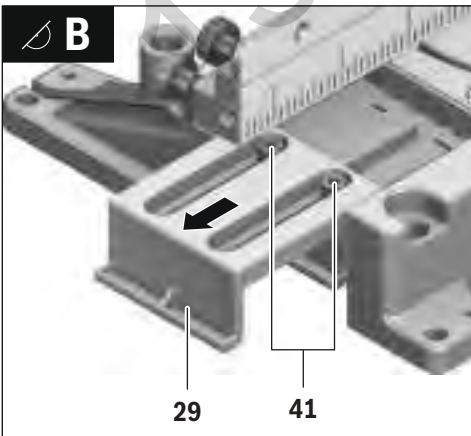

**C**

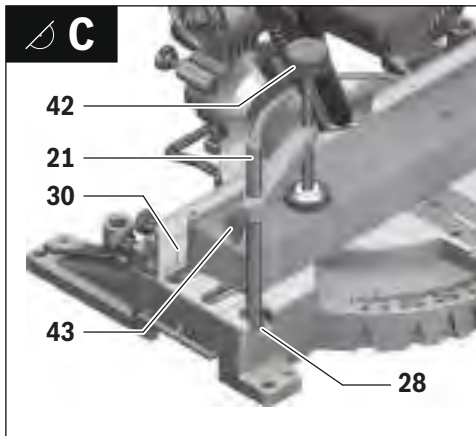

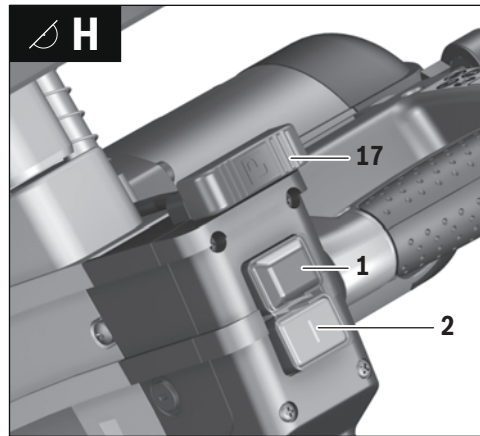
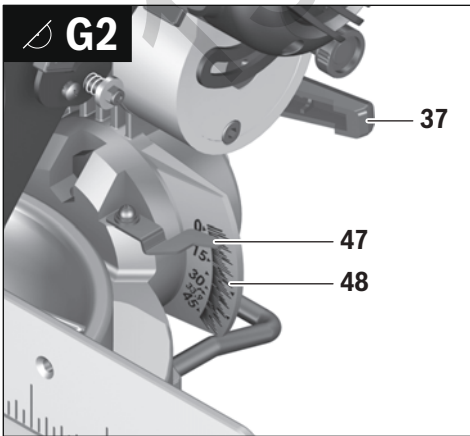
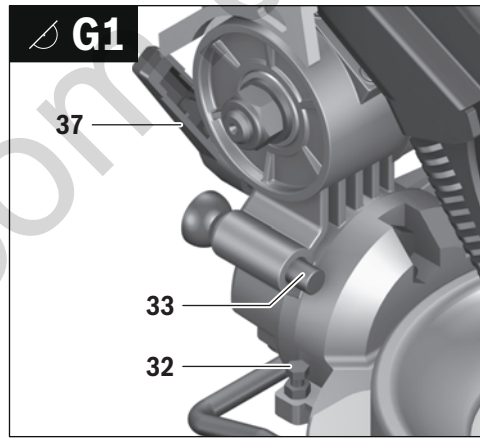
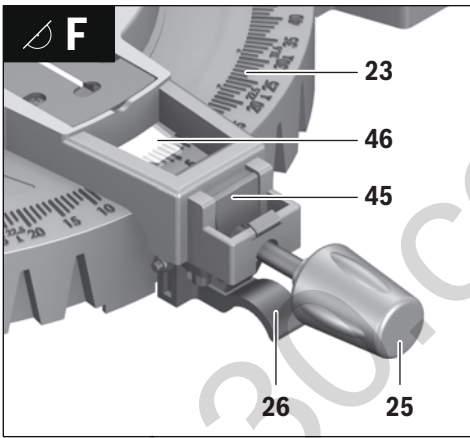
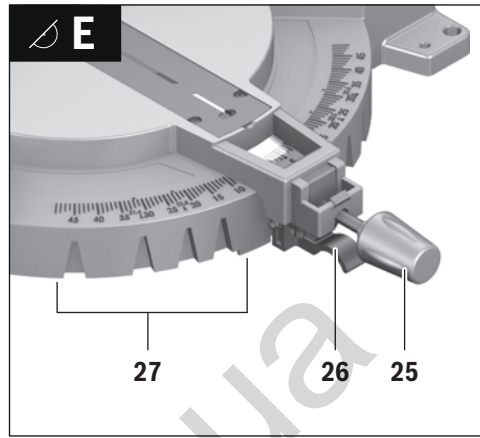
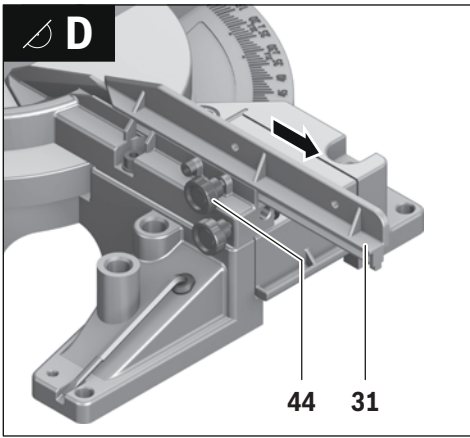

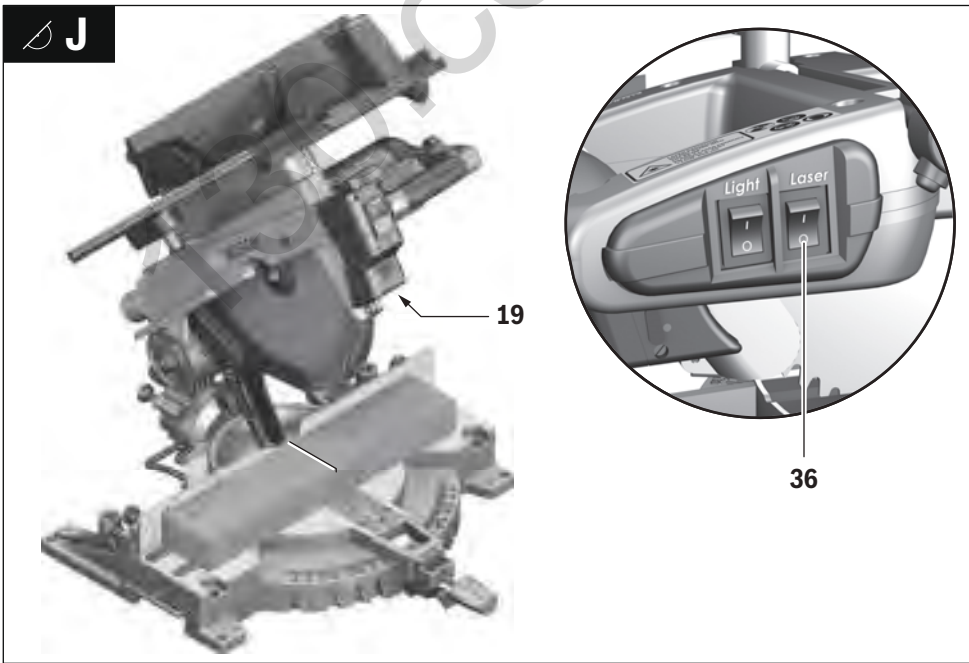
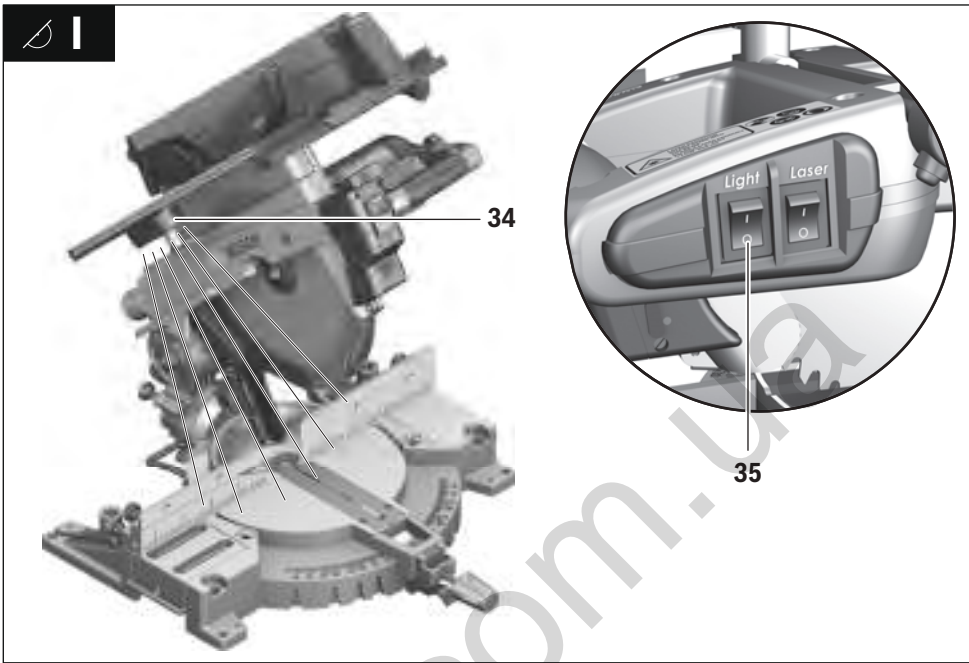



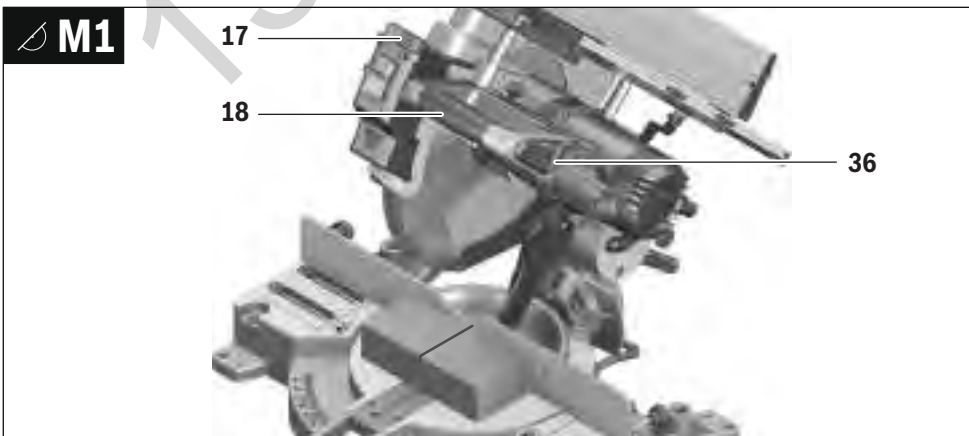
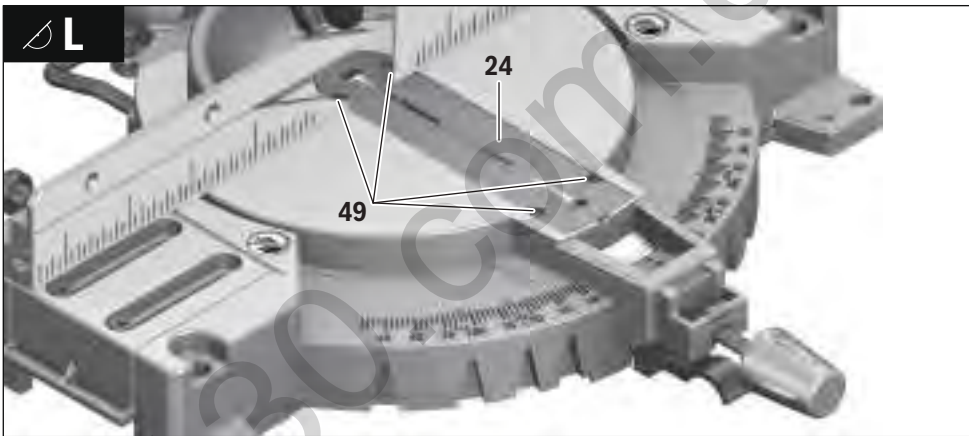
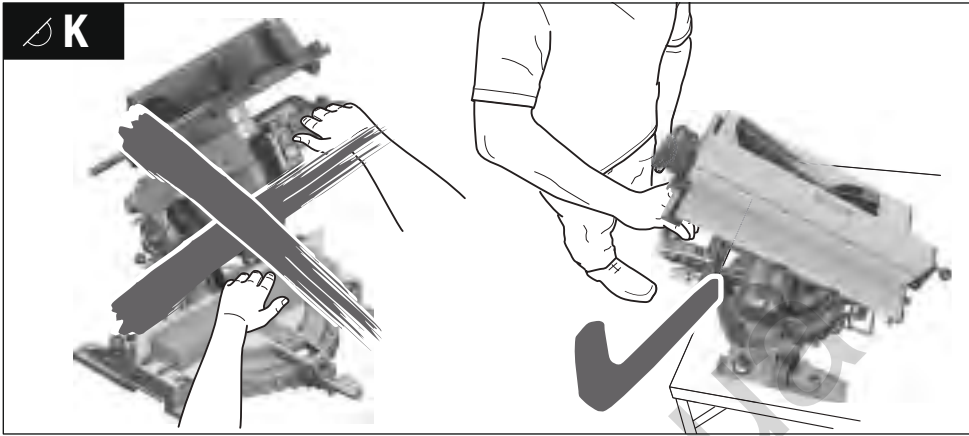

14 |

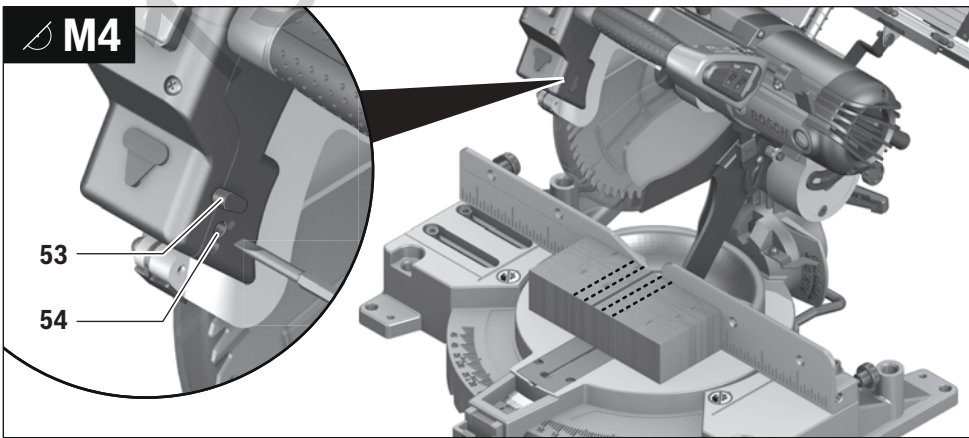
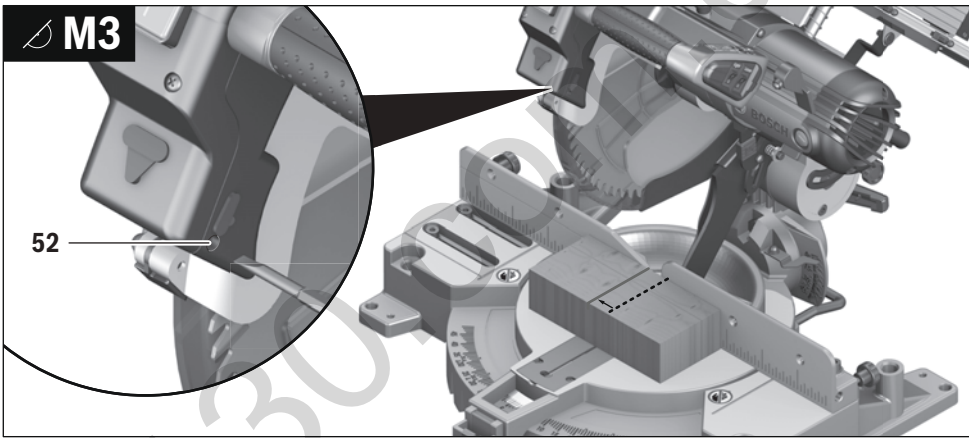
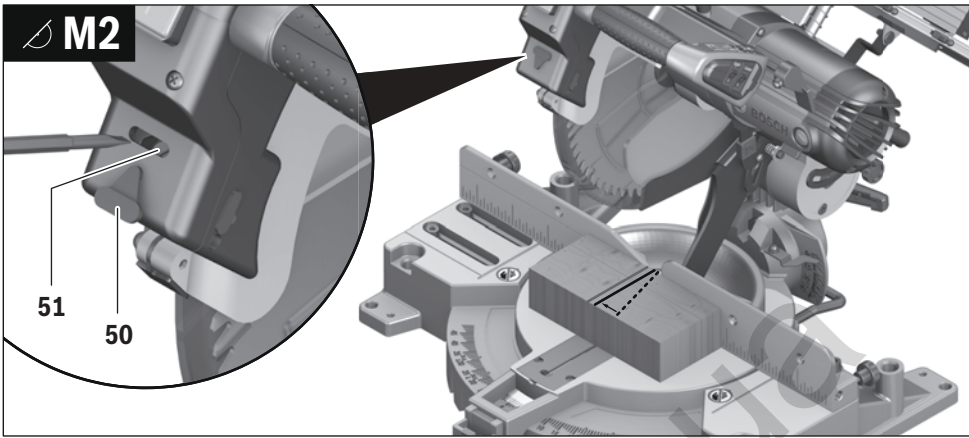

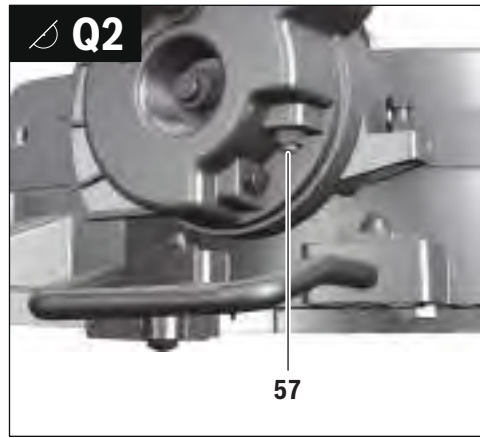
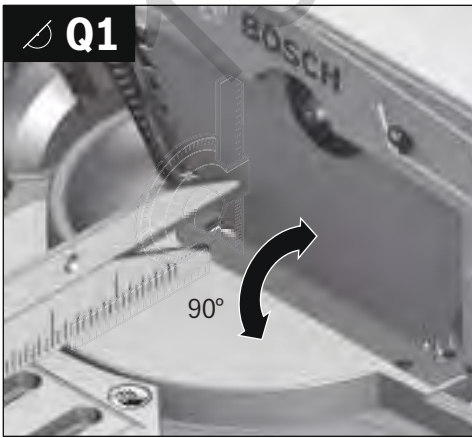
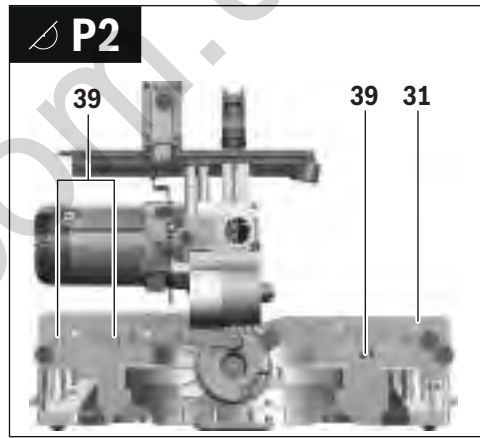
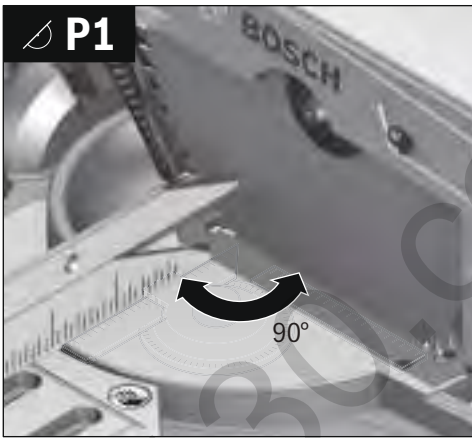
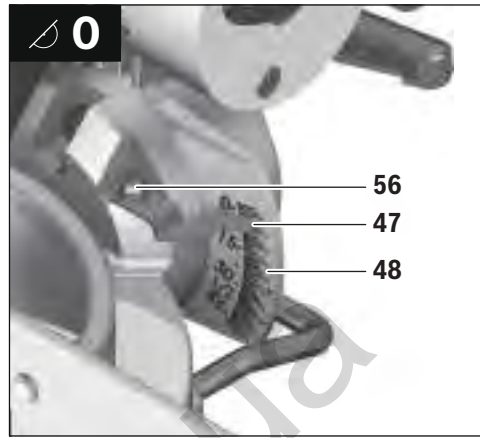
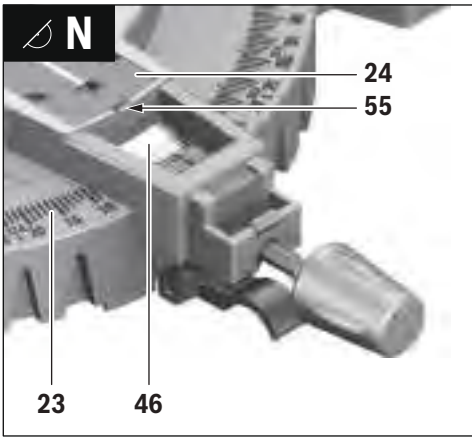

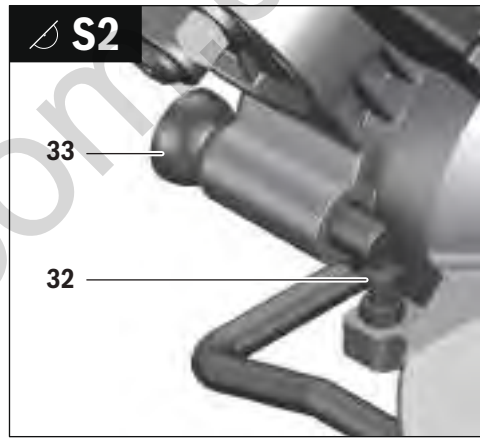
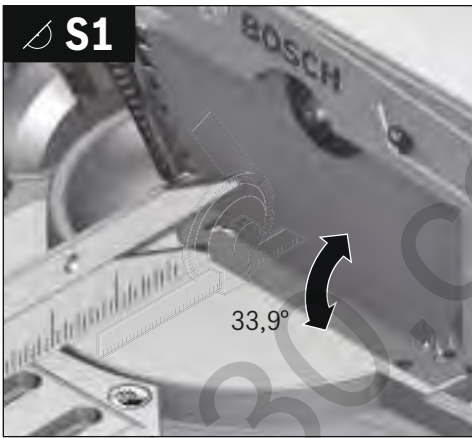
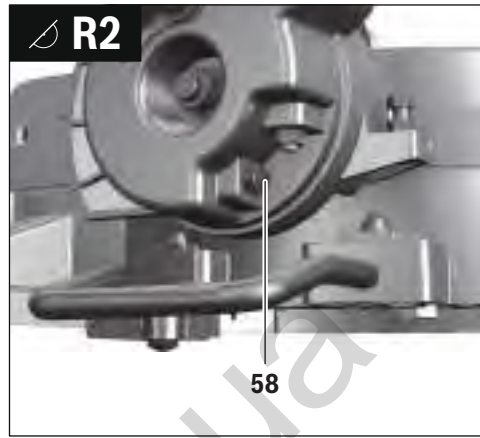
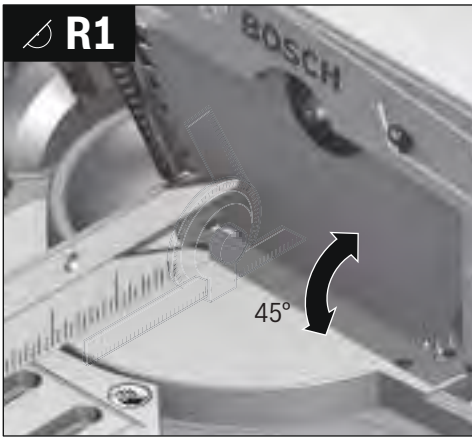

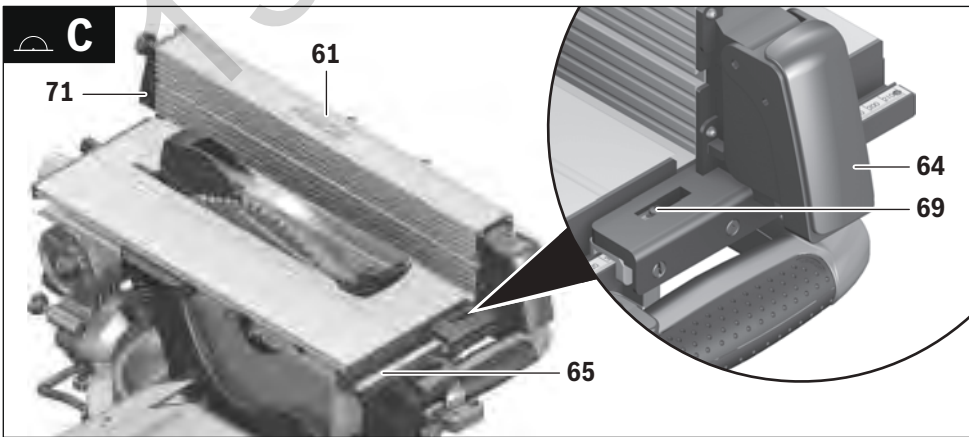
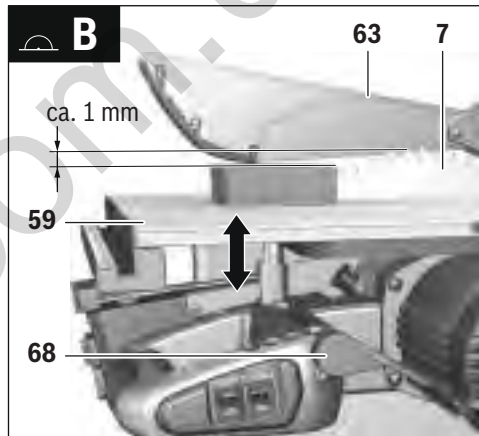
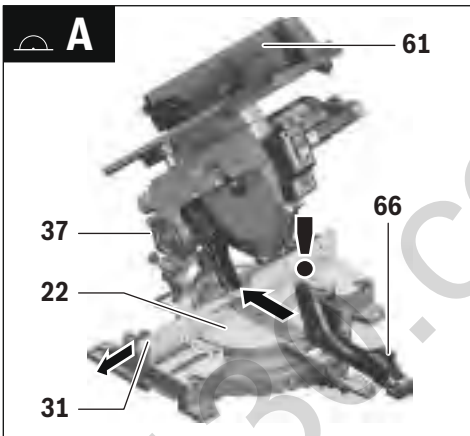
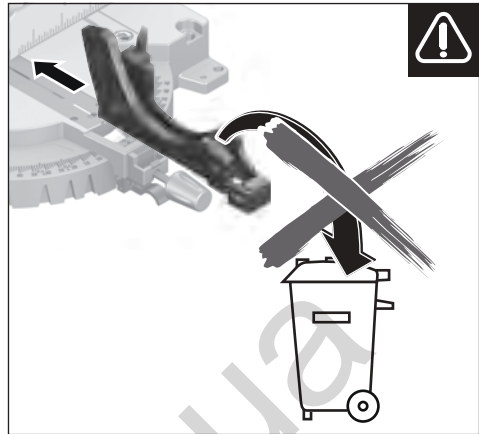



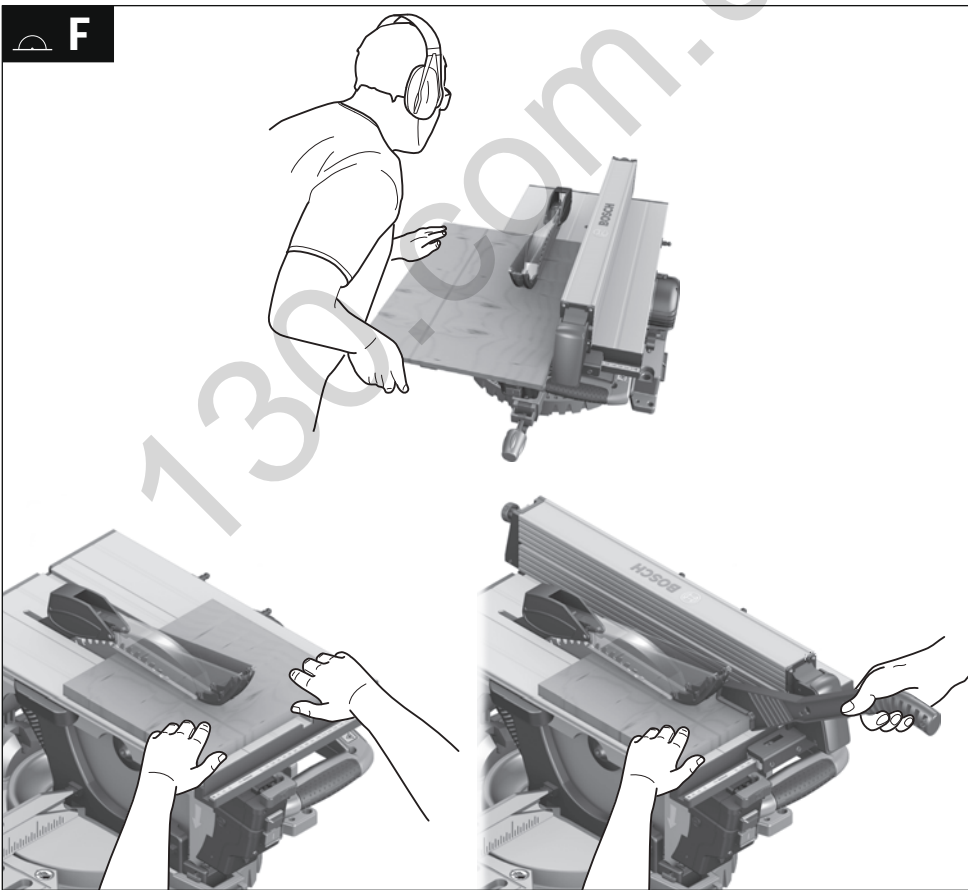
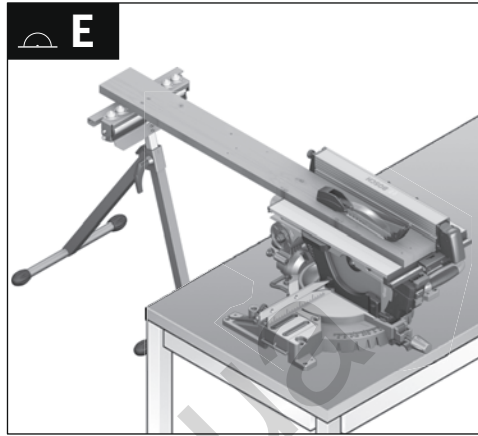
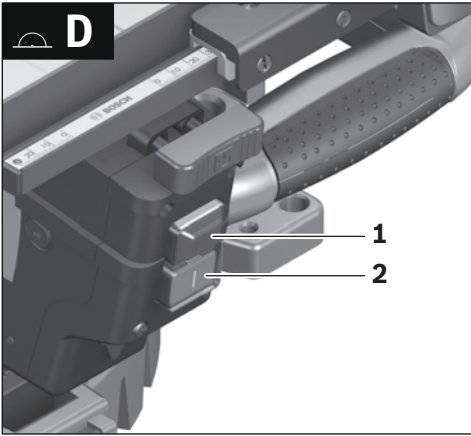

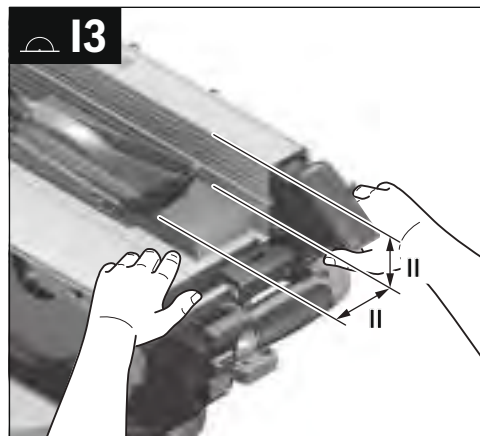
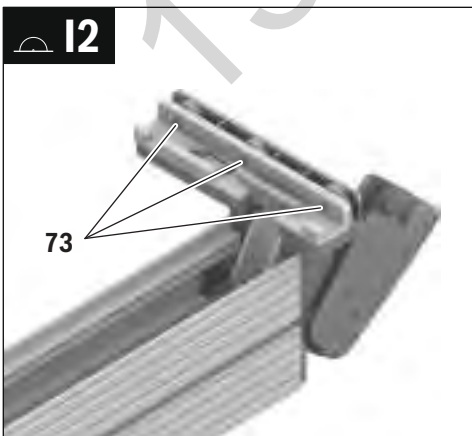
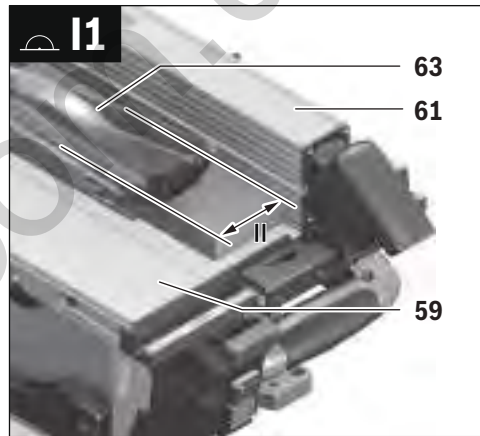
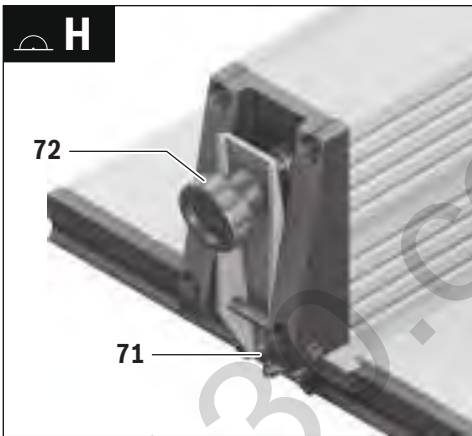
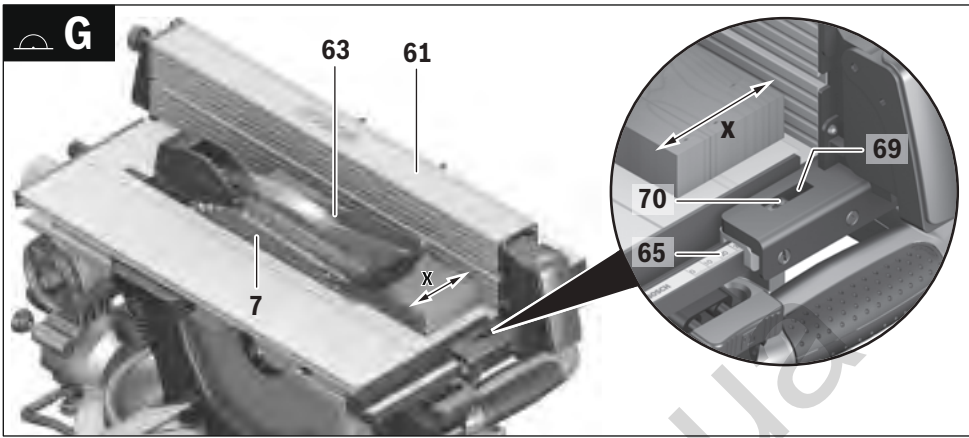

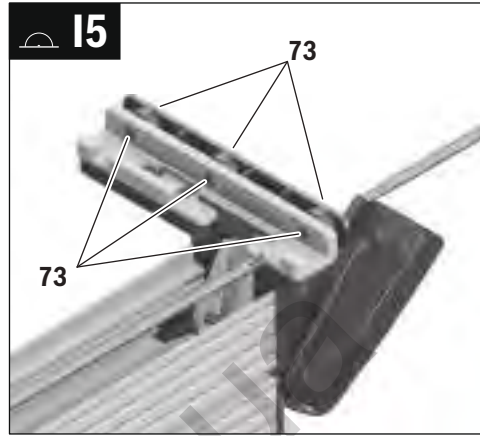
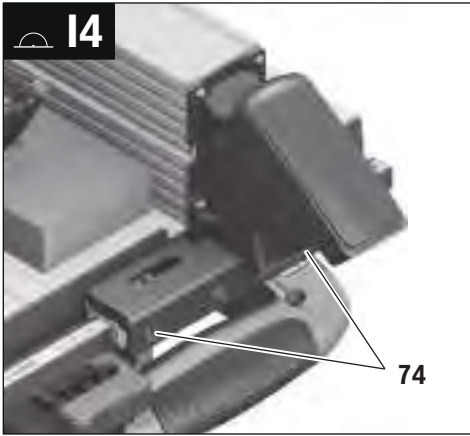

## English

### Safety Notes

#### General Power Tool Safety Warnings

**⚠ WARNING** When using electric tools basic safety precautions should always be followed to reduce the risk of fire, electric shock and personal injury including the following.

**Read all these instructions before attempting to operate this product and save these instructions.**

The term "power tool" in the warnings refers to your mains-operated (corded) power tool or battery-operated (cordless) power tool.

#### Work area safety

- ▶ **Keep work area clean and well lit.** Cluttered or dark areas invite accidents.
- ▶ **Do not operate power tools in explosive atmospheres, such as in the presence of flammable liquids, gases or dust.** Power tools create sparks which may ignite the dust or fumes.
- ▶ **Keep children and bystanders away while operating a power tool.** Distractions can cause you to lose control.

#### Electrical safety

- ▶ **Power tool plugs must match the outlet. Never modify the plug in any way. Do not use any adapter plugs with earthed (grounded) power tools.** Unmodified plugs and matching outlets will reduce risk of electric shock.
- ▶ **Avoid body contact with earthed or grounded surfaces, such as pipes, radiators, ranges and refrigerators.** There is an increased risk of electric shock if your body is earthed or grounded.
- ▶ **Do not expose power tools to rain or wet conditions.** Water entering a power tool will increase the risk of electric shock.
- ▶ **Do not abuse the cord. Never use the cord for carrying, pulling or unplugging the power tool. Keep cord away from heat, oil, sharp edges and moving parts.** Damaged or entangled cords increase the risk of electric shock.
- ▶ **When operating a power tool outdoors, use an extension cord suitable for outdoor use.** Use of a cord suitable for outdoor use reduces the risk of electric shock.
- ▶ **If operating a power tool in a damp location is unavoidable, use a residual current device (RCD) protected supply.** Use of an RCD reduces the risk of electric shock.

#### Personal safety

- ▶ **Stay alert, watch what you are doing and use common sense when operating a power tool. Do not use a power tool while you are tired or under the influence of drugs, alcohol or medication.** A moment of inattention while operating power tools may result in serious personal injury.
- ▶ **Use personal protective equipment. Always wear eye protection.** Protective equipment such as dust mask, non-skid safety shoes, hard hat, or hearing protection

used for appropriate conditions will reduce personal injuries.

- ▶ **Prevent unintentional starting. Ensure the switch is in the off-position before connecting to power source and/or battery pack, picking up or carrying the tool.** Carrying power tools with your finger on the switch or energising power tools that have the switch on invites accidents.
- ▶ **Remove any adjusting key or wrench before turning the power tool on.** A wrench or a key left attached to a rotating part of the power tool may result in personal injury.
- ▶ **Do not overreach. Keep proper footing and balance at all times.** This enables better control of the power tool in unexpected situations.
- ▶ **Dress properly. Do not wear loose clothing or jewellery. Keep your hair, clothing and gloves away from moving parts.** Loose clothes, jewellery or long hair can be caught in moving parts.
- ▶ **If devices are provided for the connection of dust extraction and collection facilities, ensure these are connected and properly used.** Use of dust collection can reduce dust-related hazards.

#### Power tool use and care

- ▶ **Do not force the power tool. Use the correct power tool for your application.** The correct power tool will do the job better and safer at the rate for which it was designed.
- ▶ **Do not use the power tool if the switch does not turn it on and off.** Any power tool that cannot be controlled with the switch is dangerous and must be repaired.
- ▶ **Disconnect the plug from the power source and/or the battery pack from the power tool before making any adjustments, changing accessories, or storing power tools.** Such preventive safety measures reduce the risk of starting the power tool accidentally.
- ▶ **Store idle power tools out of the reach of children and do not allow persons unfamiliar with the power tool or these instructions to operate the power tool.** Power tools are dangerous in the hands of untrained users.
- ▶ **Maintain power tools. Check for misalignment or binding of moving parts, breakage of parts and any other condition that may affect the power tool's operation. If damaged, have the power tool repaired before use.** Many accidents are caused by poorly maintained power tools.
- ▶ **Keep cutting tools sharp and clean.** Properly maintained cutting tools with sharp cutting edges are less likely to bind and are easier to control.
- ▶ **Use the power tool, accessories and tool bits etc. in accordance with these instructions, taking into account the working conditions and the work to be performed.** Use of the power tool for operations different from those intended could result in a hazardous situation.

#### Service

- ▶ **Have your power tool serviced by a qualified repair person using only identical replacement parts.** This will ensure that the safety of the power tool is maintained.

### Safety Warnings for Combination Saws

- ▶ **The power tool is provided with a laser warning label (marked with number 40 in the representation of the power tool on the graphics page).**



- ▶ **If the text of the warning label is not in your national language, stick the provided warning label in your national language over it before operating for the first time.**



**Do not direct the laser beam at persons or animals and do not stare into the direct or reflected laser beam yourself, not even from a distance.** You could blind somebody, cause accidents or damage your eyes.

- ▶ **If laser radiation strikes your eye, you must deliberately close your eyes and immediately turn your head away from the beam.**
- ▶ **Do not use any optical instruments such as binoculars to view the radiation source.** Doing so can damage your eye.
- ▶ **Do not direct the laser beam at persons who are looking through binoculars or similar instruments.** Doing so can damage their eye.
- ▶ **Do not make any modifications to the laser equipment.** The setting options described in these operating instructions can be used safely.
- ▶ **Do not replace the installed laser or LED with another type.** Lasers or LEDs which are not suitable for this power tool could pose dangers to persons. Repair or replacement must be performed by an authorised after-sales service centre in order to prevent safety risks.
- ▶ **Never make warning signs on the machine unrecognisable.**
- ▶ **Never stand on the power tool.** Serious injuries can occur when the power tool tips over or when inadvertently coming into contact with the saw blade.
- ▶ **Keep handles dry, clean, and free from oil and grease.** Greasy, oily handles are slippery causing loss of control.
- ▶ **Operate the power tool only when the work area to the workpiece is clear of any adjusting tools, wood chips, etc.** Small pieces of wood or other objects that come in contact with the rotating saw blade can strike the operator with high speed.
- ▶ **Keep the floor free of wood chips and material remainders.** You could slip or trip.
- ▶ **Use the machine only for cutting the materials listed under Intended Use.** Otherwise, the machine can be subject to overload.
- ▶ **If the saw blade should become jammed, switch the machine off and hold the workpiece until the saw blade comes to a complete stop. To prevent kickback, the workpiece may not be moved until after the machine has come to a complete stop.** Correct the cause for the jamming of the saw blade before restarting the machine.
- ▶ **Do not use dull, cracked, bent or damaged saw blades.** Unsharpened or improperly set saw blades produce narrow kerf causing excessive friction, blade binding and kickback.
- ▶ **Always use blades with correct size and shape (diamond versus round) of arbour holes.** Blades that do not match the mounting hardware of the saw will run eccentrically, causing loss of control.
- ▶ **Do not use high speed steel (HSS) saw blades.** Such saw blades can easily break.
- ▶ **Do not touch the saw blade after working before it has cooled.** The saw blade becomes very hot while working.
- ▶ **Do not direct the laser beam at persons or animals and do not stare into the laser beam yourself, not even from a distance.** This power tool produces laser class 2 laser radiation according to EN 60825-1. This can lead to persons being blinded.
- ▶ **Do not replace the installed laser or LED with another type.** Lasers or LEDs which are not suitable for this power tool could pose dangers to persons. Repair or replacement must be performed by an authorised after-sales service centre in order to prevent safety risks.
- ▶ **Check the cable regularly and have a damaged cable repaired only through an authorised customer service agent for Bosch power tools. Replace damaged extension cables.** This will ensure that the safety of the power tool is maintained.
- ▶ **Store the machine in a safe manner when not being used. The storage location must be dry and lockable.** This prevents the machine from storage damage, and from being operated by untrained persons.
- ▶ **Never leave the machine before it has come to a complete stop.** Cutting tools that are still running can cause injuries.
- ▶ **Never use the machine with a damaged cable. Do not touch the damaged cable and pull the mains plug when the cable is damaged while working.** Damaged cables increase the risk of an electric shock.

### Safety Warnings for Use as a Chop and Mitre Saw

- ▶ **Make sure that the guard operates properly and that it can move freely.** Never lock the guard in place when opened.
- ▶ **Never remove cutting remainders, wood chips, etc. from the sawing area while the machine is running.** Always guide the tool arm back to the neutral position first and then switch the machine off.
- ▶ **Guide the saw blade against the workpiece only when the machine is switched on.** Otherwise there is danger of kickback when the saw blade becomes wedged in the workpiece.
- ▶ **Always firmly clamp the piece to be worked. Do not saw workpieces that are too small to clamp.** Otherwise, the clearance of your hand to the rotating saw blade is too small.





- ▶ **Never operate the machine without the insert plate. Replace a defective insert plate.** Without flawless insert plates, injuries are possible from the saw blade.
- ▶ **Secure the workpiece.** A workpiece clamped with clamping devices or in a vice is held more secure than by hand.

#### Safety Warnings for Use as a Table Saw

- ▶ **Make sure that the guard operates properly and that it can move freely.** It must face against the table before sawing and against the workpiece while sawing; never lock the guard in place when opened.
- ▶ **Never reach behind the saw blade in order to hold the workpiece, remove saw dust/wood chips or for any other reason.** The clearance of your hand to the rotating saw blade is too small.
- ▶ **Guide the workpiece against the saw blade only when the machine is switched on.** Otherwise there is damage of kickback, when the saw blade becomes wedged in the workpiece.
- ▶ **Only saw one workpiece at a time.** Workpieces placed on top or aside of each other can cause the saw blade to jam or the workpieces to move against each other while sawing.
- ▶ **Always use the parallel guide or the angle guide.** This improves the cutting accuracy and reduces the possibility of saw blade binding.
- ▶ **Products sold in GB only:** Your product is fitted with a BS 1363/A approved electric plug with internal fuse (ASTA approved to BS 1362). If the plug is not suitable for your socket outlets, it should be cut off and an appropriate plug fitted in its place by an authorised customer service agent. The replacement plug should have the same fuse rating as the original plug. The severed plug must be disposed of to avoid a possible shock hazard and should never be inserted into a mains socket elsewhere.
- ▶ **Products sold in AUS and NZ only:** Use a residual current device (RCD) with a rated residual current of 30 mA or less.

## Symbols

The following symbols can be important for the operation of your power tool. Please memorise the symbols and their meanings. The correct interpretation of the symbols helps you operate the power tool better and more safely.

Symbol	Meaning
	▶ <b>Laser Radiation</b> <b>Do not stare into beam</b> <b>Class 2 laser product</b>
	▶ <b>Keep hands away from the cutting area while the machine is running.</b> Danger of injury when coming in contact with the saw blade.

Symbol	Meaning
--------	---------



▶ **Wear a dust respirator.**



▶ **Wear safety goggles.**



▶ **Wear ear protectors.** Exposure to noise can cause hearing loss.



▶ **Danger area! Keep hands, fingers or arms away from this area.**



Observe the dimensions of the saw blade. The hole diameter must match the tool spindle without play. Do not use reducers or adapters.

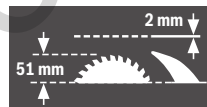

When changing the saw blade, pay attention that the kerf width is not less than 2,0 mm and the blade body thickness not greater than 2,0 mm. Otherwise, there is danger that the riving knife (2,0 mm) becomes wedged in the workpiece.

When operating the combination saw as a table saw, the maximum workpiece height is 51 mm.



Symbol on the lever **11** for tilting and locking the retracting blade guard  
*and*

symbol on the tool arm release button **17** for releasing the tool arm.

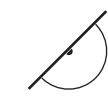

Symbol for use of the combination saw as a chop and mitre saw.



Symbol for use of the combination saw as a table saw.

## Product Description and Specifications



**Read all safety warnings and all instructions.** Failure to follow the warnings and instructions may result in electric shock, fire and/or serious injury.

### Intended Use

The power tool is intended as a stationary machine for making straight lengthways and crossways cuts in wood. Horizontal mitre angles of  $-48^\circ$  to  $+48^\circ$  as well as vertical bevel angles of  $-2^\circ$  to  $+47^\circ$  are possible.

The machine is designed with sufficient capacity for sawing hard and softwood as well as press and particle board.

When operating as a table saw, the power tool is not permitted for cutting aluminium or other non-ferrous metals or alloys.

The light of this power tool is intended to illuminate the power tool's direct area of working operation and is not suitable for household room illumination.

### Product Features

The numbering of the components shown refers to the representation of the power tool on the graphic pages.

- 1 OFF button
- 2 ON button
- 3 Mounting holes
- 4 Recessed handles
- 5 Allen key (size 6 mm)/slotted screwdriver
- 6 Tilt-protector bar
- 7 Saw blade
- 8 Dust bag
- 9 Chip ejector
- 10 Locking screw of lever **11**
- 11 Bracket
- 12 Hex socket screw for mounting of saw blade
- 13 Spindle lock
- 14 Clamping flange
- 15 Interior clamping flange
- 16 Laser lens cover

### Chop and Mitre Saw Features

- 17 Release button of the tool arm
- 18 Handle
- 19 Laser unit/Laser radiation outlet
- 20 Retracting blade guard
- 21 Material clamp
- 22 Saw table of the chop and mitre saw
- 23 Scale for mitre angle
- 24 Insert plate
- 25 Locking knob for various mitre angles
- 26 Mitre detent lever
- 27 Detents for standard mitre angles

- 28 Mounting holes for material clamp
- 29 Saw-table extension
- 30 Fence
- 31 Adjustable fence
- 32 Stop screw for  $33.9^\circ$  bevel angle (vertical)
- 33 Stop bolt for  $33.9^\circ$  bevel angle (vertical)
- 34 Lighting unit
- 35 Light switch ("Light")
- 36 Switch for marking of cutting line ("Laser")
- 37 Bevel lock lever
- 38 Transport safety-lock
- 39 Hex socket screws (6 mm) of the fence
- 40 Laser warning label
- 41 Hex socket screws of the saw table extension
- 42 Threaded rod
- 43 Wing bolt
- 44 Locking screw of the adjustable fence
- 45 Locking bracket
- 46 Fine scale
- 47 Indicator for bevel angle
- 48 Scale for bevel angle
- 49 Screws for insert plate
- 50 Rubber cap (front)
- 51 Adjustment screw for laser position (parallelism)
- 52 Adjustment screw for laser position (flush levelling)
- 53 Rubber cap (side)
- 54 Adjustment screw for laser position (lateral deviation)
- 55 Screw for fine scale
- 56 Screw for bevel angle indicator
- 57 Allen screw (size 3 mm) for standard bevel angle  $0^\circ$  (vertical)
- 58 Allen screw (size 3 mm) for standard bevel angle  $45^\circ$  (vertical)

### Table Saw Features

- 59 Saw table of the table saw
- 60 Riving knife
- 61 Parallel guide
- 62 Push stick
- 63 Blade guard
- 64 Clamping handle of the parallel guide
- 65 Scale for clearance of the saw blade to the parallel guide
- 66 Lower saw blade cover
- 67 Pins for attachment of the hold-down stick
- 68 Clamping lever
- 69 Clearance indicator
- 70 Screw for parallel guide clearance indicator
- 71 Guide of the parallel guide
- 72 Adjustment screw for tightening tension of guide **71**
- 73 Screws inside the glide pad of the parallel guide
- 74 Set screws of the parallel guide

**Material stop**

**75** Clamping screw of the material stop

**76** Drill holes for material stop

**77** Material stop\*

\*Accessories shown or described are not part of the standard delivery scope of the product. A complete overview of accessories can be found in our accessories program.

**Technical Data**

Combination Saw		GTM 12 JL	
Article number	3 601 M15 ...	... 0...	... 061
Rated power input	W	1800	1650
No-load speed	min <sup>-1</sup>	3800	3700
Laser type	nm	650	650
	mW	< 1	< 1
Laser class		2	2
Divergence of laser line		1.5 mrad (full angle)	1.5 mrad (full angle)
Weight according to EPTA-Procedure 01:2014	kg	21.1	21.1
Protection class		□/II	□/II

Permissible workpiece dimensions (maximal/minimal):

Chop/mitre saw, see page 45

Table saw, see page 48

The values given are valid for a nominal voltage [U] of 230 V. For different voltages and models for specific countries, these values can vary.

**Dimension of suitable saw blades**

Saw blade diameter	mm	300–305
Blade body thickness	mm	1.5–2.0
Mounting hole diameter	mm	30

**Noise Information**

Sound emission values determined according to EN 61029-2-11.

Typically the A-weighted noise levels of the product are:

Sound pressure level 91 dB(A); Sound power level 104 dB(A). Uncertainty K = 3 dB.

**Wear hearing protection!**

The noise emission value given in these instructions has been measured in accordance with a standardised measuring procedure and may be used to compare power tools. It may also be used for a preliminary estimation of noise emissions.

The noise emission value given represents the main applications of the power tool. However, if the power tool is used for other applications, with different accessories or is poorly maintained, the noise emission value may differ. This may significantly increase noise emissions over the total working period.

To estimate noise emissions accurately, the times when the tool is switched off, or when it is running but not actually being used, should also be taken into account. This may significantly reduce noise emissions over the total working period.

**Assembly and Transport**

- ▶ **Avoid unintentional starting of the machine. During assembly and for all work on the machine, the power plug must not be connected to the mains supply.**

**Delivery Scope**

Carefully remove all parts provided from their packaging. Remove all packing material from the power tool and the accessories provided.

Before starting the operation of the machine for the first time, check if all parts listed below have been supplied:

- Combination saw with pre-mounted saw blade
- Allen key/slotted screwdriver **5**
- Dust bag **8**

Additionally for table saw:

- Parallel guide **61**
- Push stick **62**
- Lower saw blade cover **66**

**Note:** Check the power tool for possible damage.

Before further use of the machine, check that all protective devices are fully functional. Any lightly damaged parts must be carefully checked to ensure flawless operation of the tool. All parts must be properly mounted and all conditions fulfilled that ensure faultless operation.

Damaged protective devices and parts must be immediately replaced by an authorised service centre.

**Stationary or Flexible Mounting**

- ▶ **To ensure safe handling, the machine must be mounted on a level and stable surface (e. g., workbench) prior to using.**

**Mounting to a Working Surface (see figures a – b)**

- Fasten the power tool with suitable screw fasteners to the working surface. The mounting holes **3** serve for this purpose.

or

- Clamp the power tool with commercially available screw clamps by the feet to the working surface.

**Mounting to a Bosch Saw Stand**

With the height-adjustable legs, Bosch GTA saw stands provide firm support for the power tool on any surface. The workpiece supports of the saw stand are used for underlaying long workpieces.

- ▶ **Read all safety warnings and instructions included with the worktable.** Failure to observe safety warnings and instructions can lead to electrical shock, fire and/or cause serious injuries.

- ▶ **Assemble the worktable properly before mounting the power tool.** Perfect assembly is important in order to prevent the risk of collapsing.

- Mount the power tool in transport position on the saw stand.

**Flexible Mounting (not recommended!)**

In exceptional cases, when it is not possible to mount the machine onto a level and stable work surface, it can be set up using the tilt protector.

The tilt-protector bar **6** is used for this purpose.

## 42 | English

- ▶ **Never remove the tilt-protector bar.** Without the use of the tilt-protector bar, the machine does not stand safely and can tip over, especially when sawing at maximum mitre/bevel angles.

### Dust/Chip Extraction

Dust from materials such as lead-containing coatings, some wood types, minerals and metal can be harmful to one's health. Touching or breathing-in the dust can cause allergic reactions and/or lead to respiratory infections of the user or bystanders.

Certain dust, such as oak or beech dust, is considered carcinogenic, especially in connection with wood-treatment additives (chromate, wood preservative). Materials containing asbestos may only be worked by specialists.

- Always use dust extraction.
- Provide for good ventilation of the working place.
- It is recommended to wear a P2 filter-class respirator.

Observe the relevant regulations in your country for the materials to be worked.

- ▶ **Prevent dust accumulation at the workplace.** Dust can easily ignite.

The dust/chip extraction can be blocked by dust, chips or workpiece fragments.

- Switch the machine off and pull the mains plug from the socket outlet.
- Wait until the saw blade has come to a complete stop.
- Determine the cause of the blockage and correct it.

### Integrated Dust Extraction (see figure c)

For basic dust collection, use the dust bag **8** provided.

- ▶ **Check and clean the dust bag each time after using.**
- ▶ **When sawing aluminium, remove the dust bag to avoid the risk of fire.**

During sawing, the dust bag must never come into contact with the movable machine parts.

- Press the clip of the dust bag **8** together and slide the dust bag over the saw dust ejector **9**. The clip must engage into the groove of the saw dust ejector.
- Always empty the dust bag in good time.

### External Dust Extraction

For dust extraction, a vacuum hose (size Ø 36 mm) can also be connected to the chip ejector **9**.

- Connect the vacuum hose with the chip ejector **9**.

The vacuum cleaner must be suitable for the material being worked.

When vacuuming dry dust that is especially detrimental to health or carcinogenic, use a special vacuum cleaner.

### Mounting Individual Components

- ▶ **Before any work on the machine itself, pull the mains plug.**

#### Attaching the Laser Warning Label (see figure d)

The power tool is supplied with a warning label in German language (marked with the number **40** in the representation of the power tool on the graphics page).

- Before operating for the first time, stick the provided warning label in your national language over the text of the German warning label.

#### Removing or mounting the lower saw blade cover (see figure e)

During operation as a table saw, the lower saw blade cover **66** must cover the bottom part of the saw blade.

Before using as a chop and mitre saw:

- Remove the lower saw blade cover **66** and slide it into the groove on the right-hand side of the parallel guide **61**.

- ▶ **Do not throw away the lower saw blade cover!** If the lower saw blade cover is not used, it is not possible to operate the combination saw as a table saw!

Before using as a table saw:

- Insert the lower saw blade cover **66** into the saw table **22**.

During operation as a table saw, the lower saw blade cover **66** must cover the bottom part of the saw blade.

### Changing the Saw Blade (see figures f1 – f4)

- ▶ **Before any work on the machine itself, pull the mains plug.**

- ▶ **When mounting the saw blade, wear protective gloves.** Danger of injury when touching the saw blade.

Use only saw blades whose maximum permitted speed is higher than the no-load speed of the power tool.

Never use dado sets.

Use only saw blades that correspond with the characteristic data given in these operation instructions and that are tested and marked in accordance with EN 847-1.

Use only saw blades recommended by the tool manufacturer, and suitable for sawing the materials to be cut. This prevents overheating of the saw teeth during sawing.

When changing the saw blade, pay attention that the cutting width is not smaller and the blade body thickness is not larger than the thickness of the riving knife.

#### Removing the Saw Blade

- Bring the power tool into the chop and mitre saw working position. (see "Working Position", page 43)
- Unscrew the locking screw **10** with the supplied slotted screwdriver **5**.
- Pull the lever **11** toward the right. At the same time, push the lever upward and rotate the retracting blade guard **20** toward the rear to the stop. This locks the retracting blade guard in the open position.
- Turn the hex socket screw **12** with the hex key **5** provided while at the same time pressing the spindle lock **13** until it engages.
- Hold the spindle lock **13** pressed and unscrew the hex socket screw **12** in clockwise direction (left-hand thread!).
- Remove the clamping flange **14**.
- Remove the saw blade **7**.

#### Mounting the Saw Blade

If required, clean all parts to be mounted prior to assembly.

- Place the new saw blade onto the interior clamping flange **15**.

- ▶ **Take care during the mounting that the cutting direction of the teeth (direction of the arrow on the saw blade) agrees with the direction of the arrow on the casing!**
- Place on the clamping flange **14** and the screw **12**. Press the spindle lock **13** until it engages and tighten the screw turning in anticlockwise direction.
- Push the lever **11** downward and, at the same time, rotate the retracting blade guard **20** downward again until the lever engages.
- Screw in and tighten the locking screw **10** again.

### Transport (see figure g)

- ▶ **Before any work on the machine itself, pull the mains plug.**

Before transporting the power tool, the following steps must be carried out:

- Bring the power tool into the table saw working position. (see "Working Position", page 48)
- Position the parallel guide **61** completely over the protection guard **63**. To lock the parallel guide, push the clamping knob **64** downward.
- Attach the hold-down stick onto the pins **67**.
- Insert the lower saw blade cover **66** into the saw table **22**.
- Remove all accessories that cannot be mounted firmly to the power tool. If possible, place unused saw blades in an enclosed container for transport.
- For lifting or transporting, hold the power tool by the recessed grips **4** on the side of the saw table **22**.
- ▶ **The power tool should always be carried by two persons in order to avoid back injuries.**
- ▶ **When transporting the power tool, use only the transport devices and never use the protective devices.**



### Operation as Chop and Mitre Saw

- ▶ **Before any work on the machine itself, pull the mains plug.**

### Working Position (see figure A)

If the power tool is still in the condition as delivered or if the power tool was used as a table saw, then the following steps must be carried out before using as a chop and mitre saw:

- Loosen both clamping levers **68** below the saw table **59**.
- Pull the saw table upward to the stop.
- Hold the saw table in this position and tighten the clamping levers again.
- Position the parallel guide **61** over the saw blade as a protective measure.
- Push the tool arm by the handle **18** down a little in order to relieve the transport safety-lock **38**.
- Pull the transport safety-lock **38** completely outward.

- Remove the lower saw blade cover **66** and slide it into the groove on the right-hand side of the parallel guide **61**.
- ▶ **Do not throw away the lower saw blade cover!** If the lower saw blade cover is not used, it is not possible to operate the combination saw as a table saw!
- Guide the tool arm slowly upward.
- **Loosen** locking screw **44**.
- Slide the adjustable fence **31** completely inward.
- Retighten the locking screw **44**.

### Preparing for Operation

#### Extending the Saw Table (see figure B)

Long workpieces must be underlaid or supported at their free end.

- Loosen both hex socket screws **41** with the hex key **5** provided.
- Pull out the saw table extension **29** to the stop and tighten the hex socket screws again.

#### Clamping the Workpiece (see figure C)

To ensure optimum working safety, the workpiece must always be firmly clamped.

Do not saw workpieces that are too small to clamp.

- Press the workpiece firmly against the fence **30**.
- Insert the material clamp **21** provided into one of the holes **28** intended for it.
- Loosen the wing bolt **43** and adapt the material clamp to the workpiece. Tighten the wing bolt again.
- Firmly clamp the workpiece by turning the threaded rod **42** in clockwise direction.

#### Moving the Fence (see figure D)

You have to move the adjustable fence **31** to saw bevel angles.

- **Loosen** locking screw **44**.
- Pull the adjustable fence **31** completely outward.
- Retighten the locking screw **44**.

After sawing the bevel angles, slide the adjustable fence **31** back again (loosen the locking screw **44**; slide the fence **31** completely inward; retighten the locking screw).

### Adjusting the Cutting Angle

To ensure precise cuts, the basic adjustment of the machine must be checked and adjusted as necessary after intensive use (see "Checking and Adjusting the Basic Adjustment", page 49).

- ▶ **Always tighten the locking knob 25 firmly before sawing.** Otherwise the saw blade can become wedged in the workpiece.
- Bring the power tool into the chop and mitre saw working position. (see "Working Position", page 43)

#### Adjusting Standard Mitre Angles (see figure E)

For quick and precise adjustment of commonly used mitre angles, detents **27** have been provided for on the saw table:

Left							Right
				0°			
45°	31.6°	22.5°	15°	15°	22.5°	31.6°	45°



## 44 | English

- Loosen the locking knob **25** in case it is tightened.
- Pull lever **26** and rotate the saw table **22** left or right to the requested detent.
- Release the lever again. The lever must be felt to engage in the detent.

#### Adjusting Any Mitre Angle (see figure F)

The mitre angle can be set in the range from 48° (left side) to 48° (right side).

- Loosen the locking knob **25** in case it is tightened.
- Pull lever **26** and at the same time push the locking bracket **45** until it engages in the groove intended for this. The saw table can be moved freely now.
- Turn the saw table **22** left or right by the locking knob and adjust the requested mitre angle with help of the fine scale **46**. (also see "Adjusting with Help of the Fine Scale", page 44)
- Tighten the locking knob **25** again.

#### Adjusting with Help of the Fine Scale

With the fine scale **46**, the horizontal mitre angle can be set with an accuracy of up to ¼°.

Requested setting of the initial angle X	Fine scale mark (scale 46)	... bring into alignment with the mark (scale 23)
X.25°	¼°	X + 1°
X.5°	½°	X + 2°
X.75°	¾°	X + 3°

**Example:** In order to adjust a 40.5° mitre angle, the ½° mark of the fine scale **46** must be brought into alignment with the 42° mark of scale **23**.

#### Adjusting Standard Bevel Angles (see figure G1)

For quick and precise adjustment of commonly used bevel angles, stops are provided for 0°, 45° and 33.9° angles.

- Pull the adjustable fence **31** completely outward.
- Loosen the lock lever **37**.
- **Standard angles 0° and 45°:**  
Tilt the tool arm by the handle **18** to the right stop (0°) or to the left stop (45°).
- **Standard angle 33.9°:**  
Push the stop bolt **33** completely inside. Then swivel the tool arm by the handle **18** until the bolt faces against the stop screw **32**.
- Retighten the lock lever **37** again.

#### Adjusting Any Bevel Angle (see figure G2)

The bevel angle can be set in the range from -2° to +47°.

- Pull the adjustable fence **31** completely outward.
- Loosen the lock lever **37**.
- Tilt the tool arm by the handle **18** until the angle indicator **47** indicates the desired bevel angle.
- Hold the tool arm in this position and retighten the clamping lever **37**.

### Starting Operation

- ▶ **Observe correct mains voltage! The voltage of the power source must agree with the voltage specified on the nameplate of the machine. Power tools marked with 230 V can also be operated with 220 V.**

#### Switching On (see figure H)

To save energy, only switch the power tool on when using it.

- For **starting operation**, press the green ON pushbutton **2** (I).

The tool arm can be guided down only after pushing button **17**.

- For **sawing** button **17** must therefore be pushed additionally.

#### Switching Off

- Press the red OFF pushbutton **1** (O).

#### Power Failure

The ON/OFF switch is a so-called non-voltage switch, which prevents the power tool from restarting after a power failure (e. g., when the mains plug is pulled during operation).

- To restart the power tool, press the green ON pushbutton **2** again.

### Working Advice

#### General Sawing Instructions

- ▶ **For all cuts, it must first be ensured that the saw blade at no time can come in contact with the fence, screw clamps or other machine parts. Remove any mounted auxiliary stops or adjust them accordingly.**

Protect the saw blade against impact and shock. Do not subject the saw blade to lateral pressure.

Do not saw warped/bent workpieces. The workpiece must always have a straight edge to face against the fence.

#### Illuminating the Work Area (see figure I)

Provide for sufficient lighting of the direct working area.

- For this, switch on the lighting unit **34** with the switch **35**.

#### Marking the Cutting Line (see figure J)

A laser beam indicates the cutting line of the saw blade. This allows for exact positioning of the workpiece for sawing, without having to open the retracting blade guard.

- For this, switch the laser beam on with the switch **36**.
- Align the cutting mark on your workpiece with reference to the right-hand edge of the laser line.
- Before sawing, check if the cutting line is still indicated correctly (see "Adjusting the Laser", page 46). The laser beam, as an example, can misadjust due to vibrations after intensive use.

#### Position of the Operator (see figure K)

- ▶ **Do not stand in a line with the saw blade in front of the machine. Always stand aside of the saw blade.** This protects your body against possible kickback.
- Keep hands, fingers and arms away from the rotating saw blade.
- Do not cross your arms when operating the tool arm.

**Permissible Workpiece Dimensions**

**Maximum** workpiece sizes:

Mitre/Bevel Angle		Height x Width [mm]
Horizontal	Vertical	
0°	0°	95 x 150
45° (leftward/rightward)	0°	95 x 90
0°	45°	60 x 150
45° (leftward)	45°	60 x 60
45° (rightward)	45°	60 x 100

**Minimum** workpiece sizes (= all workpieces that can be clamped left or right from the saw blade with a screw clamp): 200 x 40 mm (length x width)

**Cutting depth, max.** (0°/0°): 95 mm

**Replacing the Insert Plate (see figure L)**

The red insert plate **24** can become worn after long use of the power tool.

Replace defective insert plates.

- Bring the power tool into the chop and mitre saw working position. (see "Working Position", page 43)
- Unscrew screws **49** using a cross-head screwdriver and remove the old insert plate.

- Insert the new insert plate and screw all screws **49** in again.
- Set the vertical bevel angle to 0° and saw through the insert plate.
- Afterwards, set the vertical bevel angle to 45° and saw into the cut again.  
This procedure achieves that the insert plate is as close as possible to the teeth of the saw blade without touching it.

**Sawing**

**Cutting Off**

- Firmly clamp the workpiece as appropriate for its dimensions.
- Adjust the requested mitre and/or bevel angle.
- Switch on the machine.
- Push button **17** and slowly guide the tool arm downward with the handle **18**.
- Saw through the workpiece applying uniform feed.
- Switch off the machine and wait until the saw blade has come to a complete stop.
- Guide the tool arm slowly upward.

**Special Workpieces**

When sawing curved or round workpieces, these must be especially secured against slipping. At the cutting line, no gap may exist between workpiece, fence and saw table.

Provide for special fixtures, if required.

**Sawing Profile Strips/Mouldings (Floor and Ceiling Strips)**

Profile strips/mouldings can be sawn in two different ways:

- Placed against the fence
- Lying flat on the saw table.

Always make trial cuts with the mitre angle setting first on scrap wood.

**Floor Strips/Mouldings**

The following table contains instructions for sawing floor strips/mouldings.

Settings		Placed against the fence		Lying flat on the saw table		
Bevel angle		0°		45°		
Floor strip/moulding		Left side	Right side	Left side	Right side	
	<b>Inner corner</b>	Horizontal mitre angle	45° left	45° right	0°	0°
	Positioning of workpiece	Bottom edge on saw table	Bottom edge on saw table	Upper edge against the fence	Bottom edge against the fence	
	The finished workpiece is located ...	... to the left of the cut	... to the right of the cut	... to the left of the cut	... to the left of the cut	
	<b>Outer corner</b>	Horizontal mitre angle	45° right	45° left	0°	0°
	Positioning of workpiece	Bottom edge on saw table	Bottom edge on saw table	Bottom edge against the fence	Upper edge against the fence	
	The finished workpiece is located ...	... to the left of the cut	... to the right of the cut	... to the right of the cut	... to the right of the cut	

## 46 | English

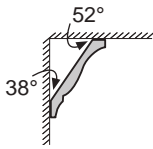
**Ceiling Strips/Mouldings (According to US Standard)**

When the ceiling strips/mouldings are to be sawn lying flat on the saw table, the standard mitre angles of 31.6° (horizontal) and 33.9° (vertical) must be set.

The following table contains instructions for sawing ceiling strips/mouldings.

Settings		Placed against the fence		Lying flat on the saw table	
Bevel angle		0°		33,9°	
Ceiling strip/moulding		Left side	Right side	Left side	Right side
	Horizontal mitre angle	45° right	45° left	31.6° right	31.6° left
	Positioning of work-piece	Bottom edge against the fence	Bottom edge against the fence	Upper edge against the fence	Bottom edge against the fence
	The finished work-piece is located ...	... to the right of the cut	... to the left of the cut	... to the left of the cut	... to the left of the cut
	Horizontal mitre angle	45° left	45° right	31.6° left	31.6° right
	Positioning of work-piece	Bottom edge against the fence	Bottom edge against the fence	Bottom edge against the fence	Upper edge against the fence
	The finished work-piece is located ...	... to the right of the cut	... to the left of the cut	... to the right of the cut	... to the right of the cut

**Checking and Adjusting the Basic Adjustment**

To ensure precise cuts, the basic adjustment of the machine must be checked and adjusted as necessary after intensive use.

A certain level of experience and appropriate specialty tools are required for this.

A Bosch after-sales service station will handle this maintenance task quickly and reliably.

**Adjusting the Laser**

- Bring the power tool into the table saw working position. (see "Working Position", page 48)
- Turn the saw table **22** to the 0° detent **27**. The lever **26** must be felt to engage in the detent.

**Checking:** (see figure M1)

- Draw a straight cutting line on the workpiece.
- Push button **17** and slowly guide the tool arm downward with the handle **18**.
- Align the workpiece in such a manner that the teeth of the saw blade are in alignment with the cutting line.
- Hold the workpiece in this position and slowly guide the tool arm upward again.
- Clamp the workpiece.
- Switch the laser beam on with switch **36**.

The laser beam must be in alignment with the cutting line on the workpiece over the complete length, also when the tool arm is lowered.

**Adjusting the Parallelism:** (see figure M2)

- Undo the rubber cap **50**.
- Screw the adjustment screw **51** in or out using a suitable screwdriver until the laser beam is parallel with the cutting line on the workpiece over the complete length.

**Adjusting the Flush Levelling:** (see figure M3)

An adjustment screw **52**, which is located below the opening marked with "R/L", is used for adjustment of the flush levelling.

- Screw the adjustment screw **52** in or out with the slotted screwdriver provided until the parallel laser beam is flush with the cutting line on the workpiece over the complete length.

One rotation in anticlockwise direction moves the laser beam from left to right; one rotation in clockwise direction moves the laser beam from right to left.

**Adjusting the Lateral Deviation while Moving the Tool****Arm:** (see figure M4)

- Open the side rubber cap **53**.
- If the laser beam **moves towards the left** when lowering the tool arm, turn adjustment screw **54** clockwise using a suitable screwdriver.
- If the laser beam **moves towards the right**, turn adjustment screw **54** anticlockwise.
- After adjusting, check the flushness with the cutting line again. If required, align the laser beam with the adjustment screw **52** again.

**Aligning the Fine Scale (see figure  N)**

- Bring the power tool into the chop and mitre saw working position. (see “Working Position”, page 43)
- Turn the saw table **22** to the 0° detent **27**. The lever **26** must be felt to engage in the detent.

**Checking:**

The 0° mark of the fine scale **46** must be in alignment with the 0° mark of the scale **23**.

**Adjusting:**

- Remove the insert plate **24**.
- Loosen the screw **55** with the slotted screwdriver provided and align the fine scale alongside the 0° marks.
- Retighten the screw again.

**Aligning the Angle Indicator (Vertically) (see figure  O)**

- Bring the power tool into the chop and mitre saw working position. (see “Working Position”, page 43)
- Turn the saw table **22** to the 0° detent **27**. The lever **26** must be felt to engage in the detent.

**Checking:**

The angle indicator **47** must be in alignment with the 0° mark of the scale **48**.

**Adjusting:**

- Loosen the screw **56** with the slotted screwdriver provided and align the angle indicator alongside the 0° mark.
- Afterwards, check to ensure that the adjustment made is correct for the 45° mark.
- Retighten the screw again.

**Aligning the Fence**

- Bring the power tool into the table saw working position. (see “Working Position”, page 48)
- Turn the saw table **22** to the 0° detent **27**. The lever **26** must be felt to engage in the detent.

**Checking:** (see figure  P1)

- Adjust an angle gauge to 90° and position it between the fence **30** and the saw blade **7** on the saw table **22**.

The leg of the angle gauge must be flush with the fence over the complete length.

**Adjusting:** (see figure  P2)

- Loosen all hex socket screws **39** with the hex key **5** provided.
- Turn the fence **30** until the angle gauge is flush over the complete length.
- Retighten the screws again.

**Setting the Standard Bevel Angle 0° (Vertical)**

- Bring the power tool into the table saw working position. (see “Working Position”, page 48)
- Turn the saw table **22** to the 0° detent **27**. The lever **26** must be felt to engage in the detent.

**Checking:** (see figure  Q1)

- Adjust an angle gauge to 90° and position it on the saw table **22**.

The leg of the angle gauge must be flush with the saw blade **7** over the complete length.

**Adjusting:** (see figure  Q2)

- Loosen the nut (size 10 mm) of the Allen screw **57**.
- Screw the Allen screw **57** with a suitable Allen wrench (size 3 mm) in or out until the leg of the angle gauge is flush with the saw blade over the complete length.
- Retighten the nut again.

In case the angle indicator **47** is not in a line with the 0° mark of the scale **48** after the adjustment, the angle indicator must be aligned accordingly (see “Aligning the Angle Indicator (Vertically)”, page 47).

**Setting the Standard Bevel Angle 45° (Vertical)**

- Bring the power tool into the table saw working position. (see “Working Position”, page 48)
- Turn the saw table **22** to the 0° detent **27**. The lever **26** must be felt to engage in the detent.
- Loosen the lock lever **37** and tilt the tool arm leftward to the stop (45°) by the handle **18**.

**Checking:** (see figure  R1)

- Adjust an angle gauge to 45° and position it on the saw table **22**.

The leg of the angle gauge must be flush with the saw blade **7** over the complete length.

**Adjusting:** (see figure  R2)

- Loosen the nut (size 10 mm) of the Allen screw **58**.
- Screw the Allen screw **58** with a suitable Allen wrench (size 3 mm) in or out until the leg of the angle gauge is flush with the saw blade over the complete length.
- Retighten the nut again.

In case the angle indicator **47** is not in a line with the 45° mark of the scale **48**, firstly check the 0° setting for the bevel angle and the angle indicator again. Then repeat the adjustment of the 45° bevel angle.

**Setting the Standard Bevel Angle 33.9° (Vertical)**

- Bring the power tool into the table saw working position. (see “Working Position”, page 48)
- Turn the saw table **22** to the 0° detent **27**. The lever **26** must be felt to engage in the detent.
- Loosen the lock lever **37**.
- Push the stop bolt **33** completely inside and swivel the tool arm until the bolt faces against the stop screw **32**.

**Checking:** (see figure  S1)

- Adjust an angle gauge to 33.9° and position it on the saw table **22**.

The leg of the angle gauge must be flush with the saw blade **7** over the complete length.

**Adjusting:** (see figure  S2)

- Loosen the nut (size 10 mm) of the stop screw **32**.
- Screw the stop screw with a suitable spanner (size 10 mm) in or out until the leg of the angle gauge is flush with the saw blade over the complete length.
- Retighten the nut again.

## Operation as Table Saw



- ▶ **Before any work on the machine itself, pull the mains plug.**

### Working Position (see figure A)

If the power tool was used as a chop and mitre saw, then the following steps must be carried out before using as a table saw:

- Bring the power tool into the chop and mitre saw working position. (see “Working Position”, page 43)
- **Loosen** locking screw **44**.
- Pull the adjustable fence **31** completely outward.
- Retighten the locking screw **44**.
- Pull the lower saw blade cover **66** out of the groove of the parallel guide **61**.
- Insert the lower saw blade cover **66** into the saw table **22**. During operation as a table saw, the lower saw blade cover **66** must cover the bottom part of the saw blade.
- Set the vertical bevel angle to 0° and tighten the lock lever **37**.
- Press release button **17** and slowly guide the tool arm by handle **18** downward until the transport safety-lock **38** can be pushed completely inward.

### Preparing for Operation

#### Adjusting the Saw Blade Height (see figure B)

For safe operation, the correct working position of the saw blade **7** to the workpiece must be adjusted. The **maximum workpiece height** is 51 mm.

- Loosen both clamping levers **68** below the saw table **59**.
- Tilt the protection guard **63** toward the rear to the stop and position your workpiece next to the saw blade.
- Push the saw table down or pull it upward until the upper saw teeth of the saw blade project approx. 1 mm above the workpiece surface.
- Hold the saw table in this position and retighten the clamping levers again.

#### Adjusting the Parallel Guide (see figure C)

The parallel guide **61** can be positioned to the right of the saw blade. The clearance indicator **69** indicates the clearance of the parallel guide to the saw blade on the scale **65**.

- Loosen the clamping knob **64**.  
This relieves the guide **71** at the rear of the parallel guide.
- Firstly, insert the parallel guide into the rear guide groove of the saw table.
- Then position the parallel guide into the front guide groove of the saw table.  
The parallel guide can be moved variably now.
- Move the parallel guide until the clearance indicator **69** indicates the requested clearance to the saw blade.
- To lock the parallel guide, push the clamping knob **64** downward again.

- ▶ **Make sure that the parallel guide is always parallel to the saw blade or that the sawblade/parallel guide clearance increases toward the rear.** Otherwise, danger is given that the workpiece is jammed between the saw blade and the parallel guide.

### Starting Operation

#### Switching On (see figure D)

- For **starting operation**, press the green ON pushbutton **2** (I).

#### Switching Off

- Press the red OFF pushbutton **1** (O).

To save energy, only switch the power tool on when using it.

#### Power Failure

The ON/OFF switch is a so-called non-voltage switch, which prevents the power tool from restarting after a power failure (e. g., when the mains plug is pulled during operation).

- To restart the power tool, press the green ON pushbutton **2** again.

### Working Advice

#### General Sawing Instructions

- ▶ **For all cuts, it must first be ensured that the saw blade at no time can come in contact with the stops or other machine parts.**

Protect the saw blade against impact and shock. Do not subject the saw blade to lateral pressure.

Pay attention that the riving knife is in line with the saw blade.

Do not saw warped/bent workpieces. The workpiece must always have a straight edge to face against the parallel guide.

Always keep/store the push stick with the power tool.

Do not use the power tool for joining, grooving or cutting slots.

Long workpieces must be underlaid or supported at their free end. (see figure  E)

#### Position of the Operator (see figure F)

- ▶ **Do not stand in a line with the saw blade in front of the machine. Always stand aside of the saw blade.** This protects your body against possible kickback.

- Keep hands, fingers and arms away from the rotating saw blade.

Observe the following instructions:

- Hold the workpiece securely with both hands and press it firmly against the saw table, especially when working without the guide.
- When sawing small workpieces, use the hold-down stick provided.

### Sawing

#### Sawing Straight Cuts

- Adjust the parallel guide **61** to the requested cutting width.
- (see “Adjusting the Parallel Guide”, page 48)
- Position the workpiece on the saw table in front of the blade guard **63**.



- Adjust the correct saw blade height (see “Adjusting the Saw Blade Height”, page 48)
- **Make sure that the blade guard is positioned properly.** It must always face against the workpiece while sawing.
- Switch on the machine.
- Saw through the workpiece applying uniform feed.
- Switch off the machine and wait until the saw blade has come to a complete stop.

### Checking and Adjusting the Basic Adjustment

#### ► Before any work on the machine itself, pull the mains plug.

To ensure precise cuts, the basic adjustment of the machine must be checked and adjusted as necessary after intensive use.

A certain level of experience and appropriate specialty tools are required for this.

A Bosch after-sales service station will handle this maintenance task quickly and reliably.

#### Adjusting the Clearance Indicator of the Parallel Guide (see figure G)

- Use a workpiece or an object with an exactly defined width x. The length of the object should approximately correspond with the diameter of the saw blade.
- Slide the object under the blade guard **63** and position it flush to the saw blade.
- Move the parallel guide **61** from the right side until it touches the object, and then lock the parallel guide in this position.

#### Checking:

The clearance indicator **69** must indicate the width x of the object on the scale **65**.

#### Adjusting:

- Loosen screw **70** with the slotted screwdriver provided and align the clearance indicator exactly to the width x.

#### Adjusting the Tension Force of the Parallel Guide (see figure H)

The tension force of the guide **71** on the parallel guide can decrease after frequent use.

- Tighten the adjustment screw **72** until the parallel guide can be firmly affixed on the saw table again.

#### Aligning the Parallel Guide Parallel to the Saw Blade



- Use a workpiece or an appropriate object with parallel edges. The length of the object should approximately correspond with the diameter of the saw blade.
- Slide the object under the blade guard **63** and position it flush to the saw blade.
- Move the parallel guide **61** from right to left until it touches the object.

#### Checking: (see figure I1)

The parallel guide must be flush with the object over the complete length.

#### Adjusting:

- Remove the parallel guide from the saw table **59** and loosen the three screws **73** inside the glide pad of the parallel guide using a Phillips screwdriver. (see figure  I2)

- Press the parallel guide from the front firmly against the scale **65** and align it flush alongside the object on the saw table. (see figure  I3)
- Hold the parallel guide in this position and tighten the left and right set screw **74** with the slotted screwdriver provided. (see figure  I4)
- Remove the parallel guide from the saw table.
- Screw the centre set screw **74** in or out until it is flush with the glide pad surface.
- Hold the respective position of each set screw and tighten all screws **73** again. (see figure  I5)

If the parallel guide can no longer be firmly attached onto the saw table after aligning, reset the tensioning force of the guide **71**. (see “Adjusting the Tension Force of the Parallel Guide”, page 49)

## Maintenance and Service

### Maintenance and Cleaning

#### ► Before any work on the machine itself, pull the mains plug.

If the replacement of the supply cord is necessary, this has to be done by Bosch or an authorized Bosch service agent in order to avoid a safety hazard.

#### Cleaning

For safe and proper working, always keep the power tool and its ventilation slots clean.

The retracting blade guard must always be able to move freely and retract automatically. Therefore, always keep the area around the retracting blade guard clean.

Remove dust and chips after each working procedure by blowing out with compressed air or with a brush.

Clean the lighting and laser unit (**34**, **19**) regularly.

To clean the laser lens cover **16**, completely unscrew the screw. Afterwards, pull the cover out of the casing alongside the retracting blade guard **20**. (see figure h)

### Accessories

	Article number
Material clamp	1 619 PA4 166
Insert plate	1 619 PA4 167
Dust bag	1 619 PA4 560
Material stop	2 608 005 131
<b>Saw blades for wood and plate materials, panels and strips/mouldings</b>	
Saw blade 305 x 30 mm, 40 teeth	2 608 640 440
<b>Saw blades for aluminium</b>	
(Operation as Chop and Mitre Saw)	
Saw blade 305 x 30 mm, 96 teeth	2 608 640 453

50 | English

**After-sales Service and Application Service**

Our after-sales service responds to your questions concerning maintenance and repair of your product as well as spare parts. Exploded views and information on spare parts can also be found under:

**www.bosch-pt.com**

Bosch's application service team will gladly answer questions concerning our products and their accessories.

In all correspondence and spare parts orders, please always include the 10-digit article number given on the nameplate of the product.

**Great Britain**

Robert Bosch Ltd. (B.S.C.)  
P.O. Box 98  
Broadwater Park  
North Orbital Road  
Denham  
Uxbridge  
UB 9 5HJ

At [www.bosch-pt.com.uk](http://www.bosch-pt.com.uk) you can order spare parts or arrange the collection of a product in need of servicing or repair.

Tel. Service: (0344) 7360109

E-Mail: [boschservicecentre@bosch.com](mailto:boschservicecentre@bosch.com)

**Ireland**

Origo Ltd.  
Unit 23 Magna Drive  
Magna Business Park  
City West  
Dublin 24

Tel. Service: (01) 4666700

Fax: (01) 4666888

**Australia, New Zealand and Pacific Islands**

Robert Bosch Australia Pty. Ltd.  
Power Tools  
Locked Bag 66  
Clayton South VIC 3169  
Customer Contact Center  
Inside Australia:  
Phone: (01300) 307044  
Fax: (01300) 307045  
Inside New Zealand:  
Phone: (0800) 543353  
Fax: (0800) 428570  
Outside AU and NZ:  
Phone: +61 3 95415555  
[www.bosch.com.au](http://www.bosch.com.au)

**Republic of South Africa****Customer service**

Hotline: (011) 6519600

**Gauteng – BSC Service Centre**

35 Roper Street, New Centre  
Johannesburg  
Tel.: (011) 4939375  
Fax: (011) 4930126  
E-Mail: [bsctools@icon.co.za](mailto:bsctools@icon.co.za)

**KZN – BSC Service Centre**

Unit E, Almar Centre  
143 Crompton Street  
Pinetown  
Tel.: (031) 7012120  
Fax: (031) 7012446  
E-Mail: [bsc.dur@za.bosch.com](mailto:bsc.dur@za.bosch.com)

**Western Cape – BSC Service Centre**

Democracy Way, Prosperity Park  
Milnerton  
Tel.: (021) 5512577  
Fax: (021) 5513223  
E-Mail: [bsc@zsd.co.za](mailto:bsc@zsd.co.za)

**Bosch Headquarters**

Midrand, Gauteng  
Tel.: (011) 6519600  
Fax: (011) 6519880  
E-Mail: [rbsa-hq.pts@za.bosch.com](mailto:rbsa-hq.pts@za.bosch.com)

**Disposal**

The machine, accessories and packaging should be sorted for environmental-friendly recycling.



Do not dispose of power tools into household waste!

**Only for EC countries:**

According to the European Directive 2012/19/EU for Waste Electrical and Electronic Equipment and its implementation into national right, power tools that are no longer usable must be collected separately and disposed of in an environmentally correct manner.

**Subject to change without notice.**