



PHONES

(044) 360-7-130
 (050) 336-0-130
 (063) 788-0-130
 (067) 233-0-130
 (068) 282-0-130

130 Internet store of autogoods

COM.UA



ICQ
 294-0-130
 597-0-130

SKYPE
 km-130

CAR RECEIVERS — Receivers • Media receivers and stations • Native receivers • CD/DVD changers • FM-modulators/USB adapters • Flash memory • Facia plates and adapters • Antennas • Accessories |
 CAR AUDIO — Car audio speakers • Amplifiers • Subwoofers • Processors • Crossovers • Headphones • Accessories | TRIP COMPUTERS — Universal computers • Model computers • Accessories |
 GPS NAVIGATORS — Portable GPS • Built-in GPS • GPS modules • GPS trackers • Antennas for GPS navigators • Accessories | VIDEO — DVR • TV sets and monitors • Car TV tuners • Cameras • Videomodules
 • Transcoders • Car TV antennas • Accessories | SECURITY SYSTEMS — Car alarms • Bike alarms • Mechanical blockers • Immobilizers • Sensors • Accessories | OPTIC AND LIGHT — Xenon • Bixenon • Lamps
 • LED • Stroboscopes • Optic and Headlights • Washers • Light, rain sensors • Accessories | PARKTRONICS AND MIRRORS — Rear parktronic • Front parktronic • Combined parktronic • Rear-view mirrors
 • Accessories | HEATING AND COOLING — Seat heaters • Mirrors heaters • Screen-wipers heaters • Engine heaters • Auto-refrigerators • Air conditioning units • Accessories | TUNING — Vibro-isolation
 • Noise-isolation • Tint films • Accessories | ACCESSORIES — Radar-detectors • Handsfree, Bluetooth • Windowlifters • Compressors • Beeps, loudspeakers • Measuring instruments • Cleaners • Carsits
 • Miscellaneous | MOUNTING — Installation kits • Upholstery • Grilles • Tubes • Cable and wire • Tools • Miscellaneous | POWER — Batteries • Converters • Start-charging equipment • Capacitors
 • Accessories | MARINE AUDIO AND ELECTRONICS — Marine receivers • Marine audio speakers • Marine subwoofers • Marine amplifiers • Accessories | CAR CARE PRODUCTS — Additives • Washer fluid •
 Care accessories • Car polish • Flavors • Adhesives and sealants | LIQUID AND OIL — Motor oil • Transmission oil • Brake fluid • Antifreeze • Technical lubricant



In store "130" you can find and buy almost all necessary goods for your auto in Kyiv and other cities, delivery by ground and postal services. Our experienced consultants will provide you with exhaustive information and help you to chose the very particular thing. We are waiting for you at the address

<http://130.com.ua>

MS-BassPro SQ

powered automotive subwoofer



OWNER'S MANUAL

INTRODUCTION

Thank you for choosing the JBL® MS-BassPro SQ powered automotive subwoofer. The MS-BassPro SQ has been designed to deliver outstanding bass performance from a compact, easily installed powered subwoofer enclosure.

To get the best performance from your MS-BassPro SQ, we strongly recommend that installation be entrusted to a qualified professional. Although these instructions explain how to install the MS-BassPro SQ in a general sense, they do not show specific installation methods that may be required for your particular vehicle. If you do not have the necessary tools or experience, do not attempt the installation yourself. Instead, please ask your authorized JBL car audio dealer about professional installation.

In order that we may better serve you should you require warranty service, please retain your original sales receipt and register your MS-BassPro SQ online at www.jbl.com.

INCLUDED ITEMS

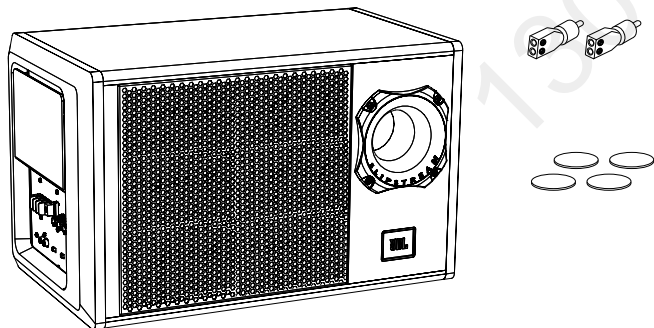

INSTALLING THE SUBWOOFER

INSTALLATION WARNINGS AND TIPS

- Always wear protective eyewear when using tools.
- Disconnect the vehicle's negative (-) battery terminal before starting the installation.
- Check clearances on both sides of a planned mounting surface. Be sure that screws or wires will not puncture brake lines, fuel lines or wiring harnesses, and that wire routing will not interfere with the safe operation of the vehicle.
- When making electrical connections, make sure they are secure and properly insulated.
- If you must replace the MS-BassPro SQ's fuse, be sure to use the same type of fuse and current rating as that of the original.

MOUNTING THE SUBWOOFER

Choose a location for the subwoofer that doesn't interfere with cargo, a fold-down rear seat or the trunk lid. The best location is usually a corner of the trunk or cargo area, as shown in the illustrations. These locations, in addition to being out of the way, will provide the best sonic reproduction in the 60Hz to 100Hz range because the woofer output will be "corner loaded" against the vehicle's walls. In any case, the MS-BassPro SQ must not interfere with the safe operation of the vehicle.

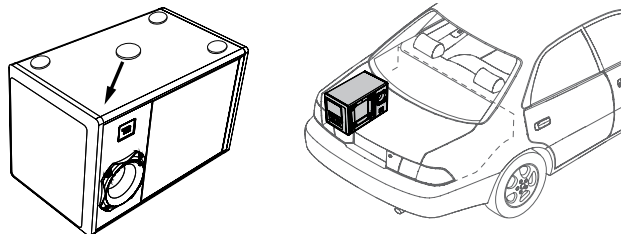

CONNECTIONS

IMPORTANT: Disconnect the vehicle's negative (-) battery terminal before beginning installation.

AUDIO SENSE SWITCH:

No remote turn on connection is necessary because the MS-BassPro SQ includes signal sensing turn on, which will turn the subwoofer on when it receives an audio signal at its input connectors. The subwoofer will automatically turn off approximately five minutes after the input signal ceases.

If your audio system's source unit includes a remote turn on wire and you would prefer to use it, defeat the signal sensing turn on circuit by moving the Audio Sense switch to the "off" position.

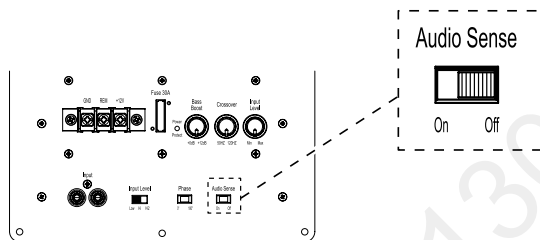

CONNECTING THE SUBWOOFER TO YOUR VEHICLE'S AUDIO SYSTEM

The JBL MS-BassPro SQ is equipped with two line-level (RCA) input connectors that can handle line-level and speaker-level input signals. Use RCA audio cables to connect the subwoofer to source units with preamp-level outputs; use the supplied bare wire-to-RCA adapters to connect the subwoofer to source units that don't have RCA output connectors. Consult the following system application diagrams to help you plan the installation of your MS-BassPro SQ. For additional installation suggestions, contact your local authorized JBL car audio dealer.

If your car audio system's head unit has front or rear stereo line-level outputs:

Use a stereo RCA audio cable (not supplied) to connect the MS-BassPro SQ to the head unit's front or rear left and right line-level outputs.

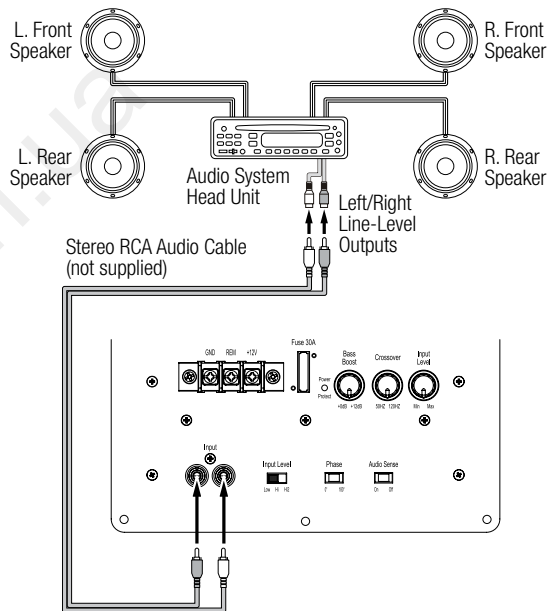

If your car audio system's head unit has a line-level subwoofer output:

If the head unit has a line-level subwoofer output, you can connect it to either of the MS-BassPro SQ's line-level input connectors.

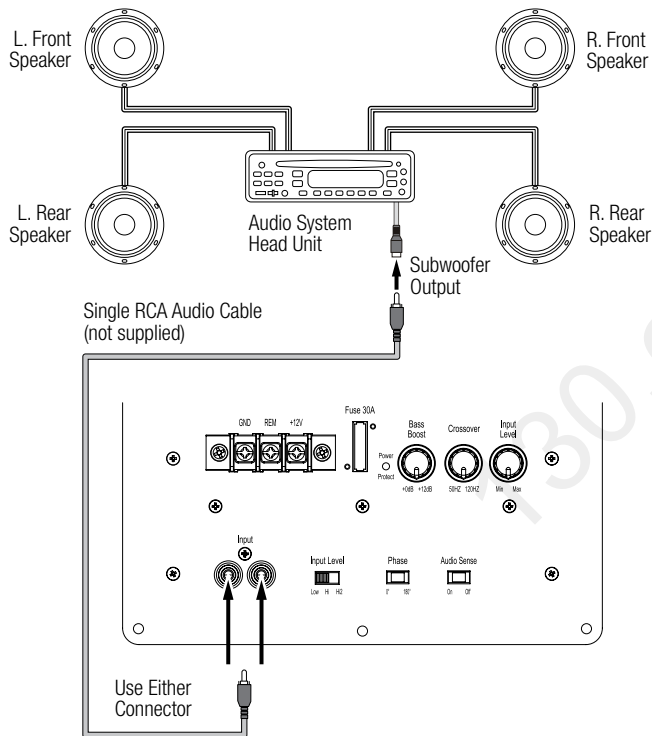

If your car audio system's head unit does not have line-level outputs:

Use the supplied bare wire-to-RCA adapters to connect the MS-BassPro SQ's inputs to either the front or the rear speaker outputs of your car audio system's head unit (splice crimps not included).

IMPORTANT: Some factory-installed audio system amplifiers include electronic filters that limit the amount of bass sent to the system's smaller speakers. This filtering will adversely affect the MS-BassPro SQ's performance. To get the most bass possible from your MS-BassPro SQ, splice the bare wire-to-RCA adapters into the factory system speaker outputs that are connected to the system's largest speakers (the ones designed to make the most bass).

Use a small phillips screwdriver to loosen the adapter's set screws and insert the speaker wires into the holes on the back of the adapter. Tighten the set screws to secure the wires.

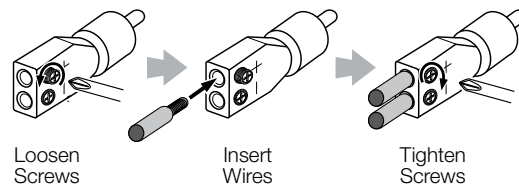

Always connect the (+) speaker wire to the adapter's (+) terminal and the (-) speaker wire to the adapter's (-) terminal.

IMPORTANT: Make sure the (+) and (-) bare wires do not touch each other. Touching wires can cause a short circuit that can damage the head unit or the subwoofer.

When you're finished, plug the adapters into the subwoofer's input connectors.

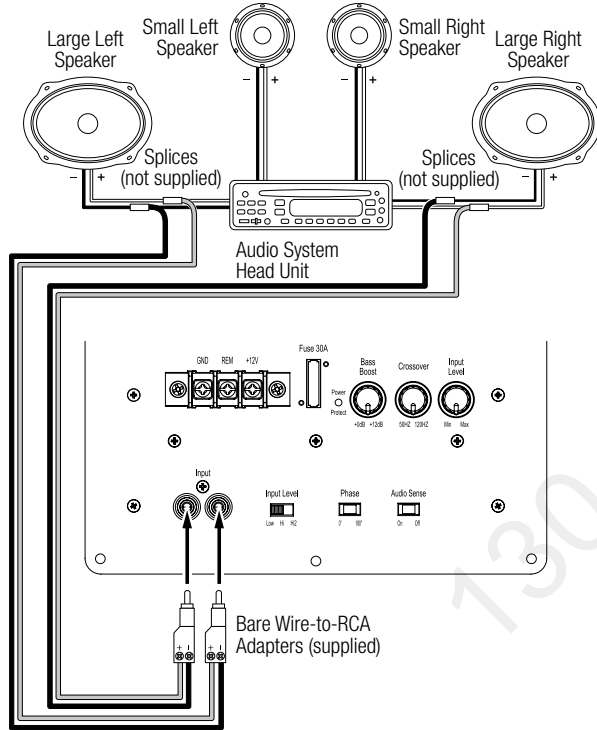

CONNECTING THE POWER AND GROUND

Use at least 10 AWG (2.59mm) wire for the positive battery (“+12V”) and ground (“GND”) connections. Connect the MS-BassPro SQ’s “+12V” terminal directly to the battery’s “+” (positive) terminal. Install a fuse holder with a 30A fuse within 18” (46cm) of the battery’s “+” terminal.

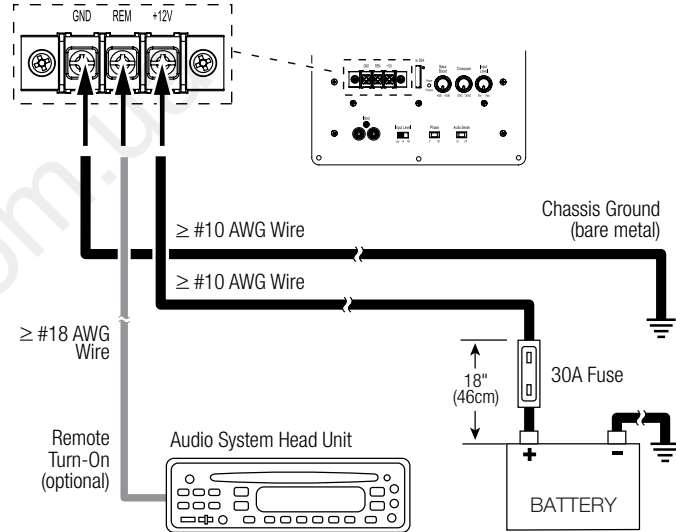

Route all power wires through grommets in the vehicle’s firewall. If factory grommets are not available, install grommets yourself. Connect the ground wire from the MS-BassPro SQ’s “GND” terminal to the nearest bare-metal surface on the vehicle. For a good connection, use sandpaper to clear the paint from the metal surface and use a screw with a star-type lock washer.

USING THE SUBWOOFER

WARNING: Playing loud music in an automobile can hinder your ability to hear traffic and permanently damage your hearing. We recommend listening at low or moderate levels while driving your car. We accept no liability for hearing loss, bodily injury or property damage resulting from the use or misuse of this product.

CONTROLS AND FUNCTIONS

The JBL MS-BassPro SQ's control panel features controls and indicators that make it easy for you to integrate the subwoofer's sound with almost any vehicle's unique acoustic properties. For specific instructions on using the MS-BassPro SQ's controls, see Setting the Controls, on page 7.

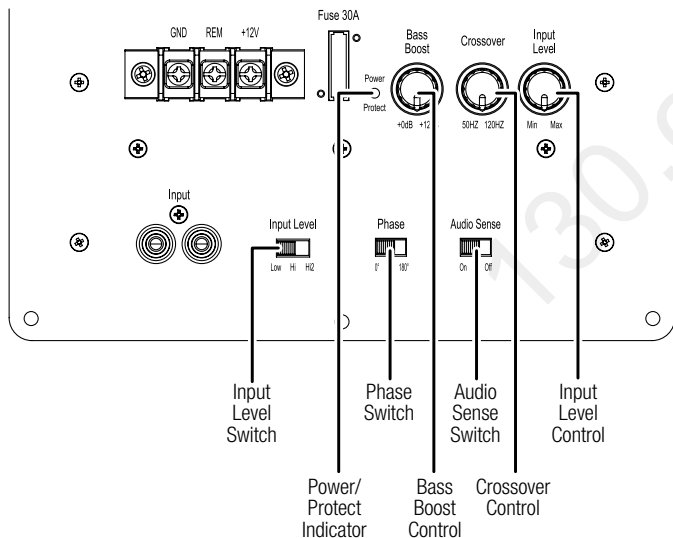

Input Level switch: Use this switch along with the Input Level control to set the MS-BassPro SQ's input level. Start the control-setting process on page 7 with the Input Level switch set in the "Hi" position.

NOTE: If you have connected the MS-BassPro SQ to a factory audio system's speaker outputs, the audio system may fail to play or may display a "speaker disconnected" message. If this happens, change the Input Level switch to the "Hi2" position. The "Hi2" position includes a circuit designed to fool this type of factory audio system into "seeing" a speaker connected to its output.

IMPORTANT: The Hi2 setting should never be used when the MS-BassPro SQ is connected to an aftermarket head unit's line-level (RCA-type) outputs.

Power/Protect indicator: This LED will illuminate red continually when the subwoofer is operating, and will flash red when the subwoofer is in the protection mode. See *Troubleshooting*, on page 8, for more information.

Phase switch: This switch will reverse the phase of the MS-BassPro SQ's output with respect to its input. When you install the MS-BassPro SQ with an existing factory or aftermarket system, changing the Phase switch setting to reverse the subwoofer's phase may produce a discernable increase or decrease in the amount of upper bass that the system reproduces, depending on the MS-BassPro SQ's location in the vehicle and the distance between it and the other speakers in the vehicle.

Bass Boost control: Use this control to increase the amount of low bass output from the MS-BassPro SQ. The Bass Boost control provides up to 12dB of boost at 40Hz.

Audio Sense switch: If you did not connect the MS-BassPro SQ's Remote Turn-On connector, set the Audio Sense switch to the "On" position. If you did connect the MS-BassPro SQ's Remote Turn-On connector, set the Audio Sense switch to the "Off" position.

Crossover control: Use this control to adjust the amount of high-frequency information present in the MS-BassPro SQ's output. A lower value allows less high-frequency content.

Input Level control: Use this control to balance the relative volume of the MS-BassPro SQ with the other speakers in the vehicle.

SETTING THE CONTROLS

1. Make sure the head-unit power is off and the MS-BassPro SQ's Input Level control is set to minimum.
2. Set the MS-BassPro SQ's Crossover control to its maximum frequency of 120Hz and set the Bass Boost control to the 12 o'clock setting.

NOTE: If you are using a Wireless Bass Control with the MS-BassPro SQ (sold separately), set it to maximum.

3. Turn the head unit on and play a selection of your favorite music track that has substantial bass.
4. Adjust the Crossover control counterclockwise until you hear only bass information coming from the MS-BassPro SQ. For example, you should not hear vocals coming from the subwoofer when you are seated in the normal listening position.
5. Adjust the Bass Boost control either clockwise or counterclockwise to suit your taste. Be sure to find a setting that does not create audible distortion in the subwoofer's sound.

IMPORTANT: If in the next step the MS-BassPro SQ's volume is too low even with the Input Level control turned all the way up, turn the Input Level control all the way down (full counterclockwise) and change the subwoofer's Input Level switch to the "Low" position. Then repeat the next step.

6a. If you installed the Wireless Bass Control, set the MS-BassPro SQ's Input Level control to its maximum and set the remote level control's knob to the maximum level that provides undistorted output from the MS-BassPro SQ with the head unit's volume control at its 3 o'clock setting. Use the Wireless Bass Control to adjust the subwoofer volume according to your taste while avoiding distortion from the MS-BassPro SQ.

6b. If you did not install the Wireless Bass Control, adjust the MS-BassPro SQ's Input Level control to the maximum level that provides undistorted output from the MS-BassPro SQ with the head unit's volume control at its 3 o'clock setting. After using the subwoofer for a while, if you find that this setting produces too much bass, you can reduce the subwoofer's Input Level control setting.

7. With the Phase switch set at 0°, play a music track that has impactful drums, and listen for the upper bass content, paying attention to the impact of the drums. Then set the Phase switch to 180°, and listen to the same music again. There may be more upper bass, less upper bass or no change at all. The Phase switch position that provides the most upper bass is technically correct, but you can choose either setting according to your taste.

NOTE: In most cases the above steps will provide you with satisfactory results. However, the actual process may require several readjustments of each control, since the settings will interact with one another. If necessary, consult your authorized JBL car audio dealer for help in tuning your system.

TROUBLESHOOTING

If your subwoofer isn't performing the way you think it should, check to see if the problem is covered in this section before calling your dealer or contacting JBL customer service.

Problem	Causes and Solutions
Power indicator is not lit.	<ol style="list-style-type: none">1. +12V wire fuse or subwoofer fuse is blown and needs replacement.2. Head unit not functioning properly.3. Check remote turn-on, +12V and GND connections.
Power indicator is illuminated red continually, but there is no bass.	<ol style="list-style-type: none">1. Inputs are not properly connected. Check connections.2. Head-unit fader controls are not set properly. Adjust head-unit controls to feed audio signals to the subwoofer.3. Incorrect subwoofer Level control setting.
Power indicator is flashing red, and there is no bass.	<ol style="list-style-type: none">1. Subwoofer is in protection mode. Turn audio system off. When subwoofer Power indicator turns off, turn audio system back on and operate at reduced volume. If subwoofer returns to normal operation, reduce subwoofer Input Level and/or Bass Boost control settings. If subwoofer returns to protection mode, contact your authorized JBL dealer.
Output sounds muddy or distorted.	<ol style="list-style-type: none">1. Subwoofer Level control is set too high.2. Subwoofer Bass Boost control is set too high.3. Subwoofer Crossover frequency selection is too high. Select a lower crossover frequency.4. Bass level is set too high on head unit.5. Head-unit output is distorted or blown. See your authorized JBL car audio dealer.
Output gets louder when the head-unit balance is adjusted to L or R.	Using speaker-level input connections: One of the speaker-level input connections is reversed (+/-). Reverse one channel.

TROUBLESHOOTING (CONTINUED)

Problem	Causes and Solutions
Not Enough Bass.	<ol style="list-style-type: none"> 1. Crossover frequency setting too low. Select a higher crossover frequency. 2. Input Level control setting is incorrect. Increase Input Level control setting or set Input Level switch to "Low" position. 3. Audio system includes a high-pass filter designed to limit bass sent to small speakers. If you're using an aftermarket head unit that includes a high-pass filter (HPF) on the outputs connected to the subwoofer, turn the HPF off in the head unit's menu. If you're splicing the subwoofer's bare wire-to-RCA adapters into a factory audio system's speaker outputs, try splicing them into a different pair of speaker outputs. See <i>If your car audio system's head unit does not have line-level outputs</i>, on page 4.

SPECIFICATIONS

Low-frequency transducer:	10" square diaphragm
Amplifier power:	300W RMS
Frequency response:	20Hz – 150Hz
Fuse rating:	30A
Max current draw:	25A
Idle current draw:	400mA
Input sensitivity:	40mV – 20V
Crossover frequency:	50Hz – 120Hz, variable
Crossover slope:	12dB/octave
Dimensions (W x H x D):	20-5/8" x 12-3/8" x 11-3/8" (523mm x 314mm x 289mm)
Weight:	32.8 lb (14.9kg)



HARMAN HARMAN Consumer, Inc.
8500 Balboa Boulevard, Northridge, CA 91329 USA

© 2011 HARMAN International Industries, Incorporated. All rights reserved.

JBL and BassPro are trademarks of HARMAN International Industries, Incorporated, registered in the United States and/or other countries.

Features, specifications and appearance are subject to change without notice.

Part No. 950-0407-001