



PHONES

(044) 360-7-130
(050) 336-0-130
(063) 788-0-130
(067) 233-0-130
(068) 282-0-130

130 Internet store of autogoods

COM.UA



ICQ
294-0-130
597-0-130

SKYPE
km-130

CAR RECEIVERS — Receivers • Media receivers and stations • Native receivers • CD/DVD changers • FM-modulators/USB adapters • Flash memory • Facia plates and adapters • Antennas • Accessories |
CAR AUDIO — Car audio speakers • Amplifiers • Subwoofers • Processors • Crossovers • Headphones • Accessories | TRIP COMPUTERS — Universal computers • Model computers • Accessories |
GPS NAVIGATORS — Portable GPS • Built-in GPS • GPS modules • GPS trackers • Antennas for GPS navigators • Accessories | VIDEO — DVR • TV sets and monitors • Car TV tuners • Cameras • Videomodules
• Transcoders • Car TV antennas • Accessories | SECURITY SYSTEMS — Car alarms • Bike alarms • Mechanical blockers • Immobilizers • Sensors • Accessories | OPTIC AND LIGHT — Xenon • Bixenon • Lamps
• LED • Stroboscopes • Optic and Headlights • Washers • Light, rain sensors • Accessories | PARKTRONICS AND MIRRORS — Rear parktronic • Front parktronic • Combined parktronic • Rear-view mirrors
• Accessories | HEATING AND COOLING — Seat heaters • Mirrors heaters • Screen-wipers heaters • Engine heaters • Auto-refrigerators • Air conditioning units • Accessories | TUNING — Vibro-isolation
• Noise-isolation • Tint films • Accessories | ACCESSORIES — Radar-detectors • Handsfree, Bluetooth • Windowlifters • Compressors • Beeps, loudspeakers • Measuring instruments • Cleaners • Carsits
• Miscellaneous | MOUNTING — Installation kits • Upholstery • Grilles • Tubes • Cable and wire • Tools • Miscellaneous | POWER — Batteries • Converters • Start-charging equipment • Capacitors
• Accessories | MARINE AUDIO AND ELECTRONICS — Marine receivers • Marine audio speakers • Marine subwoofers • Marine amplifiers • Accessories | CAR CARE PRODUCTS — Additives • Washer fluid •
Care accessories • Car polish • Flavors • Adhesives and sealants | LIQUID AND OIL — Motor oil • Transmission oil • Brake fluid • Antifreeze • Technical lubricant



In store "130" you can find and buy almost all necessary goods for your auto in Kyiv and other cities, delivery by ground and postal services. Our experienced consultants will provide you with exhaustive information and help you to chose the very particular thing. We are waiting for you at the address

<http://130.com.ua>



How to install and operate the DLS ULTIMATE A-series amplifiers A2, A3, A4, A5, A6, and A7

Welcome!

This owners manual is written in easy english and uses a lot of drawings to simply the installation and use of the above amplifiers.

Your DLS amplifier must be installed correctly in order to work well. This manual will show you how to install the amplifier like a pro. Please read the entire manual before beginning the installation. Install the amplifier yourself if you feel confident with our instructions and if you have the proper tools. However if you feel unsure, turn over the installation job to someone better suited to it.

Warranty Service

This amplifier is covered by warranty, depending on the conditions in the country where it is sold. If the amplifier is returned for service, please include the original dated receipt with the product.



Technical Assistance

For technical assistance ask the shop where the product was sold, or the distributor in your country. You can always phone the DLS Helpdesk in Sweden + 46 31 84 00 60 or send an e-mail to info@dls.se. Information can also be found on our WEB-site www.dls.se

Contents

Caution.....	2
Installation.....	2
Tools and materials needed.....	3
Amplifier installation kit.....	3
Routing Wires.....	3
Wiring	
Power terminals.....	4
Inputs and controls.....	5
Input wiring.....	5
Input level control.....	5
Phase control.....	5
Remote bass level.....	5
Protection circuits.....	5
Input & controls A7.....	6
Crossovers / filters.....	7
Crossovers / filters A7.....	8
Professional tips.....	9
Wiring examples:	
DLS A2.....	10-11
DLS A3.....	12-13
DLS A4.....	14-16
DLS A5.....	17
DLS A6.....	18
DLS A7.....	19-22
Testing.....	23
Trouble-shooting.....	23
Specifications.....	24-25

Approval of electromagnetic compatability according to the EEC Directive 95/54/EC for DLS A2, A3, A4, A5, A6, A7.

 Approval No: 10R-020962





Congratulations, you have just purchased the finest mobile audio amplifier that today's technology can offer. DLS offers a series of high quality car audio products for real music lovers, and we are sure that you will enjoy a high class car sound for many years.



CAUTION!

Some of our amplifiers are capable of producing a sound pressure level that can cause permanent damage to your hearing system. High sound pressure levels combined with long time listening can give permanent damage to your hearing system. Choose a listening level that is comfortable for your ears.

To establish a safe level:

Start your volume control at a low setting. Slowly increase the volume until you can hear the music comfortably and clearly, without any distortion. Sudden sound shocks are dangerous.

The following noises can be dangerous with constant exposure:

90 dB	Subway, motorcycle, lawn mower	4 hours max
100 dB	Chain saw	2 hours max
120 dB	Rock band live concert	30 minutes max
140 dB	Gunshot blast, jet plane	0 minutes

Installation

Before you begin to install

Before you begin you need to read the manual, to have some tools, cables and other material available. There is one such list of material on the following page.

Amplifier location

Important

Allow air circulation around the amplifier.

The DLS ULTIMATE amplifiers have a great flexibility in mounting but the best is to mount it somewhere in the trunk.

When you select a location, do remember that the amplifier generates a lot of heat.

Choose a location where air can circulate freely around the amplifier. Do not cover the amplifier with carpets or hide behind trim panels.

Do **NOT** mount the amplifier upside down under the hat rack.

In the amplifier case there are four mounting holes. If the surface where you intend to mount the amplifier isn't big enough you can mount it on a separate fibre board or similar. This will also isolate the amplifier chassies from ground.

WARNING!

Check all locations and placements carefully before making any cuts, drilling any holes or making any connections.

Disconnect Battery

Before starting the installation, always disconnect the negative terminal of the battery.

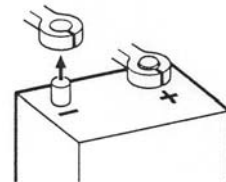

Professional Tip:

If amplifier installation kits are available with different size of power cable, choose the most heavy power cable to improve sound quality and to allow more amplifiers to be installed now or later.

These are the minimum sizes of power cables we recommend for the different models:

	Cable length: < 1,5 m	1,5 - 4 m	>4 m
A2	10 mm ²	16 mm ²	21 mm ²
A3 / A4 / A5	16 mm ²	21 mm ²	33 mm ²
A6	21 mm ²	33 mm ²	50 mm ²
A7	16 mm ²	21 mm ²	33 mm ²
A8	10 mm ²	16 mm ²	21 mm ²

The ground cable must have the same size.

Max fuse values for different cable sizes:

6 mm ² (9 AWG) :25 A	10 mm ² (7AWG) :40 A
16 mm ² (5AWG) :60 A	21 mm ² (4AWG) :100 A
33 mm ² (2AWG) :150 A	42 mm ² (1AWG) :200 A

Tools and material needed

Tools:

- ◆ Flat and Phillips screwdrivers
- ◆ Wire cutter
- ◆ Wire stripper
- ◆ Electric drill with drills
- ◆ Crimping tool
- ◆ Digital multimeter or test lamp
- ◆ Wire brush, scraper or a piece of an abrasive sheet to remove paint for a good ground connection
- ◆ Grease to protect the ground connection from oxidation

Material:

- ◆ Speaker wire: minimum 12 AWG = 4 mm² for subwoofers 13 – 16 AWG = 1,5-2,5 mm² for other speakers
- ◆ Sheet metal screws for mounting the amplifier to the amplifier board and the amplifier board to the car + some extra for fuse holder, amplifier ground etc.
- ◆ Electrical insulation tape
- ◆ ½ inch thick plywood or particle board for the amplifier to be mounted upon.

Amplifier installation kit:

If available, buy an amplifier installation kit. It contains normally all you need. This is what you have to buy if you buy the items separately

- ◆ 20- 25 feet = 6- 7.5 meter power cable, preferably AWG 5 = 16 mm² or heavier. See the table on previous page to find out what cable size you need.
- ◆ 1 pc of fuseholder to install close to the car battery + fuse 80 Ampere, or other value depending on what cable and amplifier you use. See the table on page 2.
- ◆ 20 feet of AWG 15 = 1,5 mm² wire for remote turn on / off cable from head unit.
- ◆ RCA-cable for input from head unit. - 20 feet or 5 meter for trunk installations You can connect all inputs together and use only one RCA-cable, or use separate wires to each input.
- ◆ Two min. 5 gauge ring crimp terminals—one for connection to the battery plus and one for the amplifier ground connection.
- ◆ Wire ties
- ◆ Insulating grommet or insulating tube

Routing wires

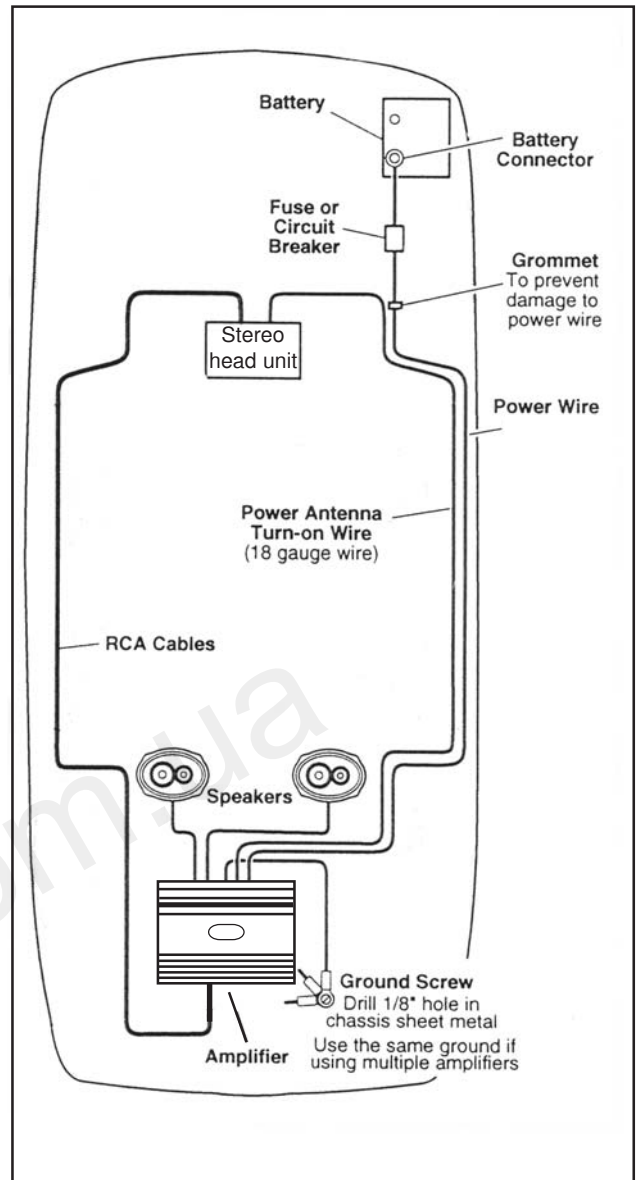

Professional Tip:

Gauge (ga) is an American measure for cable size, also called AWG (American Wire Gauge).

CONVERSION GAUGE - mm²

0 AWG = 50 mm ²	9 AWG = 6,8 mm ²
1 AWG = 42 mm ²	10 AWG = 5,3 mm ²
2 AWG = 33 mm ²	11 AWG = 4,2 mm ²
3 AWG = 27 mm ²	12 AWG = 3 mm ²
4 AWG = 21 mm ²	13 AWG = 2,7 mm ²
5 AWG = 16 mm ²	14 AWG = 2 mm ²
6 AWG = 13 mm ²	15 AWG = 1,65 mm ²
7 AWG = 10 mm ²	16 AWG = 1,3 mm ²
8 AWG = 8 mm ²	

Wiring

Power, remote and fan terminals

Power terminal for A2, A5, A7

Connect the fuse holder as close to the vehicle battery + as possible, using AWG 5 = 16 mm² or heavier cable (see table on page 2). Use ring crimp terminal cable to connect to battery +. Apply silicon grease to the fuse to prevent corrosion.

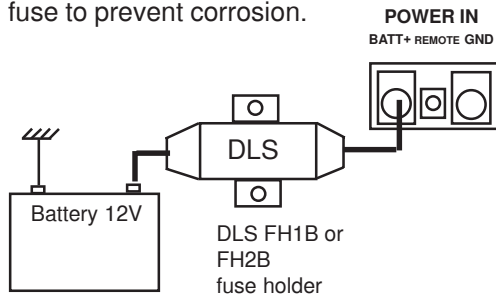

Connect the battery cable to the +12 Volt terminal on the amplifier. Model A2, A5 and A7 accepts AWG 4 = 21 mm² direct into the terminal. Be sure to use a rubber grommet or a plastic insulating tube where the cable passes the firewall or other places where it can easily be jammed. Use wire ties to secure to existing cables in the engine compartment.

Power terminal for A3, A4 & A6

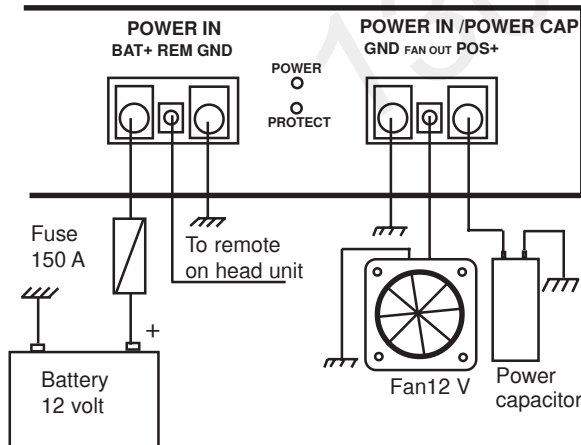

These models have double DC inputs. The terminals are internally connected so it's enough to connect just one of them. If you want to reduce the voltage drop to the amplifier, use both inputs. The extra DC input can also be used for the connection of a Power Capacitor or an extra battery. See the example above. These amplifiers requires a powerful fuse holder like the FH2B with an ANL 150 Amp fuse (when using 2AWG / 33 mm² power cable).

Remote terminal (REM)

For RCA cable signal input:

Connect the radio power antenna lead = remote turn on/off from the head unit to the amplifier remote connection. This turns on the amplifier whenever the car stereo is turned on.

You can either use the built in remote cable in the RCA cable itself, or use a separate cable.

Sometimes a small disturbance may enter the amplifier coming from the remote voltage, through the built in remote wire and into the RCA cable. Thus we recommend to use a separate remote wire and run the RCA lead separate from remote wire, power cables and speaker cables.

You can insert the cable directly into the amplifier terminal. If there is no remote voltage available from the stereo, you must connect to the ignition key, through the radio, or any accessories fuse.

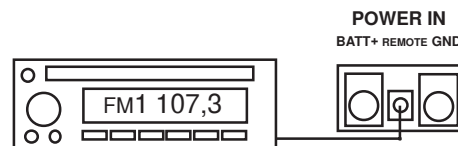

Ground Terminal (GND)

Connect to a good chassis ground. The ground connection should be clean, unpainted metal to provide a good electrical connection. Use a wire brush, a scraper or a piece of an abrasive sheet to clean the metal. Use a lock washer or two to secure contact. Protect with silicon grease or by paint applied afterwards.

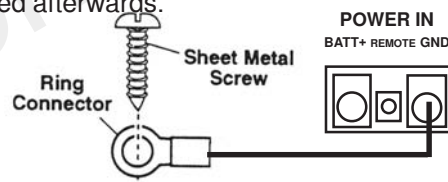

Fan terminal

DLS A3, A4, A5, A6 and A7 has a fan output terminal. On A3, A4 and A6 the terminal is combined with the extra DC-terminal. The output is electronically controlled and starts if the amplifiers is overheated. The terminal is marked "FAN".

Use a 12 volt DC fan. The speed of the fan increases when the temperature rises. Direct the fan towards the amplifier cooling ribs. Full speed is obtained at 70 degrees C. **NOTE!** Maximum load on the FAN terminal is 0,5 Amp.

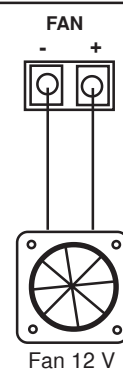

Fuses

Use only ATC blade type fuses. Make sure to replace with the same value. The value is printed above the fuse holders. DLS A4 has no internal fuses, use an external fuse instead.

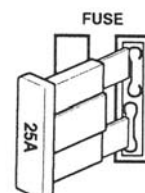



Input and controls

Input Wiring

Inputs are low level from the RCA output of the head unit.

Low level input

Use a pair of shielded stereo audio cables with RCA type jack. Most trunk-mount amplifiers need a 20 feet RCA cable (appr 5 – 6 meters). Most under the seat installations require 12 feet (2 – 3 meters) RCA cables. Avoid placing the RCA cable close to speaker cables, power cables and remote control cable.

DLS A2 and A3 uses a single pair of RCA inputs while three and four channels amplifiers like A4 & A5 uses dual pairs of RCA inputs

A7 is a multi channel amplifier with three separate inputs. On next page you can see how to connect the RCA inputs of A7.

Use high quality interconnects like the DLS SL5 PRO or SL5 Ultimate that has an effective shielding. When you run the signal cables remember to keep them well spaced from the wiring loom and the power feed to the amplifier to avoid picking up interference. Lay the power cables and signal cables separated on each side of the car. Any extra cable must be laid in zig-zag style and definitely not coiled.

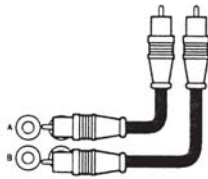

Input Level control

LEVEL



The input level control, 7V – 0,2 V, matches the output of your head unit to the input of the amplifier. After installation is complete, make sure the input of the amplifier is turned down all the way (counter-clockwise at 7V). Play a tape or CD, make sure all bass or treble settings or equalizer are flat, and turn the volume of the radio up until you just start to hear distortion. Turn the volume control down just a bit. On the amplifier increase the input level control (clockwise or to the right) until you just start to hear distortion, then back the level control just a bit. Now your radio and amplifier levels are matched.

On three/ four channel amplifiers like the A4, A5 or A7 it's necessary to adjust the levels individually to achieve a good sound balance between the different speakers, different speakers have different sensitivity. When using two of the channels for subwoofer operation, start the level adjustment on these channels. After having adjusted the bass level for good performance, adjust the level to the front system for a good sound balance.

Phase control on A5, A6 and A7

The phase control on can be set continuously from 0 - 180 degrees. This is very useful when you want to adjust the bass sound for best front stage image. Start at 0 and turn the control slowly clockwise until you experience that the bass sound is coming from the front. If you dont get the result you want, also try to phase reverse the subwoofer connections and make a new adjustment. On A5 you find this control on the amplifiers left side.

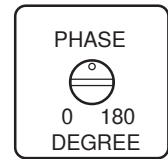

Remote bass level and phase shift control on A5, A6 and A7

A remote level and phase shift control is included with A5, A6 and A7 amplifiers. You can adjust the bass level and phase from the front seat of your vehicle. Connect it to the socket marked Remote Bass Level. When using a remote level control you must activate it by pushing the switch besides the socket, to IN-position.



Remote Bass Level & phase shift control

Power / Protect light

Power (Blue)



Protect (Red)



The power light (blue) is turned on when the amplifier is turned on.

The protect light (red) is turned on when the amplifier shuts down from overheating, or a short circuit (speaker failure)

The amplifiers have an internal high current protection circuit shutting down the amplifier if the current draw is too high. It is indicated with a LED marked "PROTECT". The protection circuits will reset by turning the head unit off and on again.

The amplifiers also have a thermal protection that turns off the amplifier if getting to hot. It will resume operation after cooling down. If necessary install an external cooling fan.

There are one or two fuses on the front. Disconnect the main fuse before replacing any of these. Always replace with the same type and value.



Input and controls A7

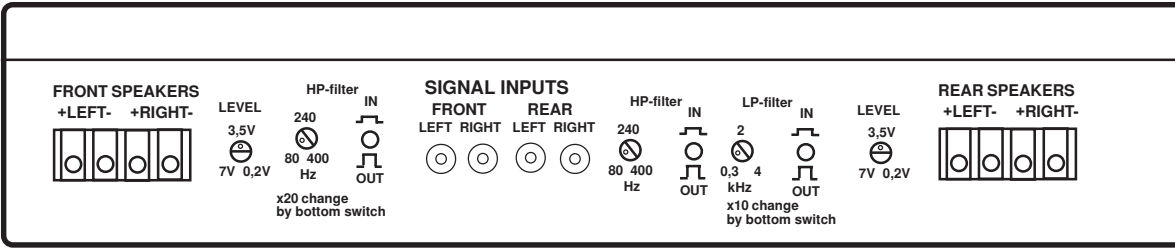

Input Wiring

DLS A7 has a more sophisticated input configuration and can be connected in different ways which are described here. Inputs are low level from the RCA output of the car stereo head unit.

Low level input

Use a pair of shielded stereo audio cables with RCA type jack. Most trunk-mount amplifiers need a 20 feet RCA cable (appr 5 – 6 meters). Most under the seat installations require 12 feet (2–3 meters) RCA cables. Avoid placing the RCA cable close to speaker cables, power cables and remote control cable.

The amplifier has separate input sockets for front, rear and sub channel.

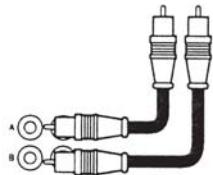

There are two switches located under the amplifier bottom plate. With these switches you can choose different ways to connect the RCA input sockets internally. You can use either one, two or three separate RCA cables for the feed. Use any of the following:

1. One RCA cable feed to all amplifier inputs.

If you want to use only one RCA cable to feed all inputs set the switches like in the example below:

A single RCA feeds all channels

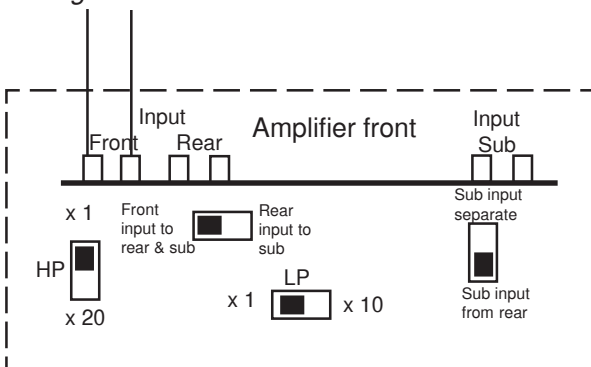

2. Two RCA cables. One to front input and the other to rear and sub inputs.

If you want to use a separate RCA cable to the front channels and another RCA cable to rear and sub channels connect the cables and set the switches like in the example below:

Separate input cables to front and rear. Then internally connected to the sub channel.

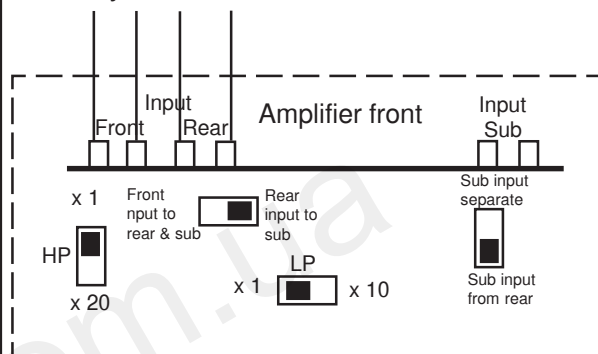

3. Three RCA cables. One to front input, one to rear input, and the third to sub input.

If you want to use separate RCA cables to all inputs, set the switches like in the example below:

Separate input cables to all channels.

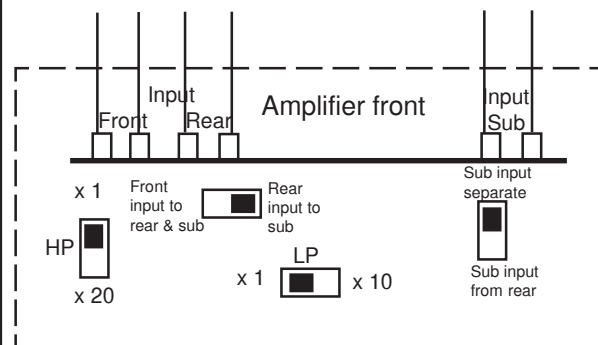



Crossovers / filters (general)

DLS A-series amplifiers include highpass filter (**HP**) and lowpass filters (**LP**).

The **HP-filters** can be used in one of two ways. Either as a **subsonic filter** together with a subwoofer to remove the lowest frequencies which often causes a rumbling bass reproduction. A normal setting is 20 - 30 Hz.

The HP-filter can also be used together with a front or rear stereo system to remove frequencies below the crossover setting. In a system with a separate subwoofer it's normal to limit the bass reproduction to the front system. A normal setting is between 80 - 100 Hz, but feel free to try other settings.

If you have problems with the mid bass driver "reaching the bottom" (the voice coil reaches the bottom pole plate) at high volumes, use the HP-filter to avoid this with a setting at 50 - 80 Hz.

A subsonic filter is actually a HP-filter.

The **LP-filters** are normally used when you connect a subwoofer in bridge mode. The filter can be switched in and out. A normal setting is 70 - 80 Hz. The filter slope is 12 dB.

Active crossover.

A4 and A7 the LP and HP-filters have a frequency range making it possible to use them for active crossover to a 2-way speakersystem.

Crossovers on each model

DLS A2 och A3

DLS A2 and A3 has an adjustable LP-filter that can be switched in/out. It can be set from 50 - 125 Hz. There is also an adjustable HP-filter that can be switched in/out. The filter is adjustable from 20 - 200 Hz.

PHASE SHIFT BUTTON ON A3:

DLS A3 has a button marked "**PHASE**". Use this button to phase reverse the speaker output. The button is only working when the lowpass filter is in use. Only use this button when you want to phase reverse a subwoofer to get the best sound.

DLS A4

DLS A4 is equipped with adjustable HP-and LP- filters on all channels. These can also be switched in/out. The filters are equipped with a multiplication button for improved flexibility.

The filter setup are as follows:

Front:

Lowpass (LP) 50 - 125 Hz

Highpass (HP) 20 - 200 Hz alt 60 - 600 Hz (x 3 button)

Rear:

Lowpass (LP) 45 - 200 Hz alt. 90 - 400 Hz (x 2 button)

Highpass (HP) 20 - 200 Hz

The x2 and x3 buttons are used if you run a 2-way system with active crossover between mid-bass and tweeter.

DLS A5

Front channels:

DLS A5 has an internal adjustable HP-filter that can be switched in/out. It can be set from 50 up to 150 Hz.

Sub / mono channel:

The mono channel filters are for use only with one or more subwoofers There is a LP-filter adjustable from 40 up to 90 Hz, and a subsonic filter at 25 Hz that can be switched in-out.

DLS A6

DLS A6 is a mono amplifier for use only as a subwoofer amplifier.

It has a fixed 25 Hz subsonic filter that can be switched in/out.

It also has a LP-filter adjustable from 50 - 125 Hz. This filter can not be disconnected.

DLS A7

This is a five channel amplifier with a lot of filter possibilities described in detail on page 8.

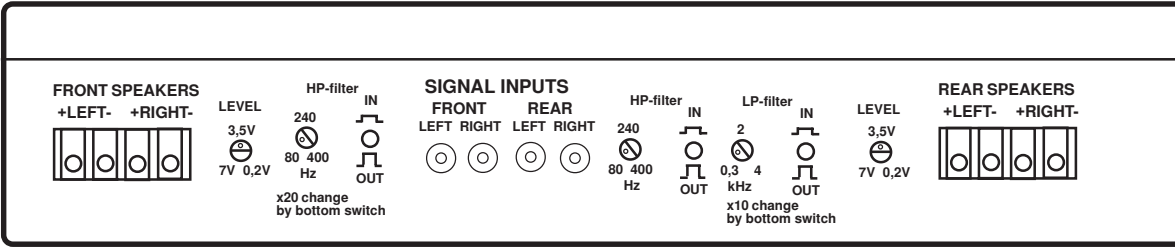

Crossovers / filters on A7

DLS A7 amplifier include highpass filter (HP), lowpass filter (LP). On the two front channels the HP-filter can be switched between two different frequency ranges, likewise for the LP-filter on the rear channels.

Highpass filter on front channels

The slope of the HP-filter is 12 dB / octave.

The filter can be switched off if you want to run the amplifier in full range mode. Or use as a HP-filter for tweeters if you want to run a 2-way speaker system with active crossover. The HP x20 switch under the bottom plate changes the filters frequency range from the normal 80-400 Hz to 1600 - 8000 Hz. A normal setting is 3-5 kHz.

If you run a 3-way system on the amplifier you can use this filter for active crossover between midbass and midrange speakers, a typical setting is 400 Hz.

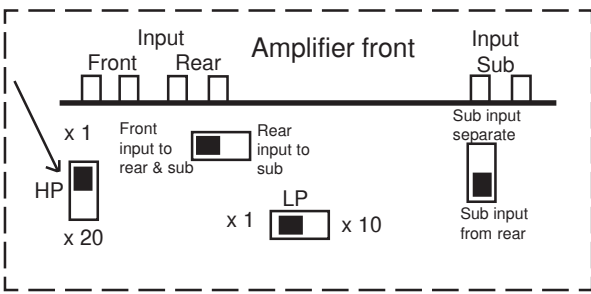
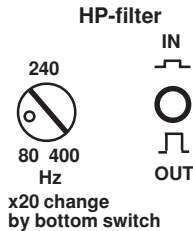

Filters on sub channel

The sub channel is made only for subwoofer use and has a variable LP-filter that can be switched on-off. A normal setting for the LP-filter is 60-80 Hz.

Lowpass



Lowpass filter on rear channels

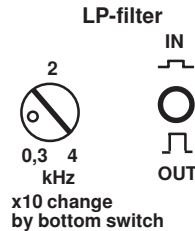

The LP-filter on the rear channels is used when you run a 2-way or 3-way speaker system with active crossover. It will allow low frequencies only and blocks higher frequencies. The filter can be switched in and out.

The normal frequency range is from 0,3 to 4 kHz. With the LP x10 switch, under the bottom plate, you can change the filter frequency range from the normal to 3 - 40 kHz. A normal x-over setting is 3-4 kHz when used for active crossover in a 2-way system.

If you run a 3-way system on the amplifier you can use this filter for active crossover between midbass and midrange speakers. A typical setting is 400 Hz.

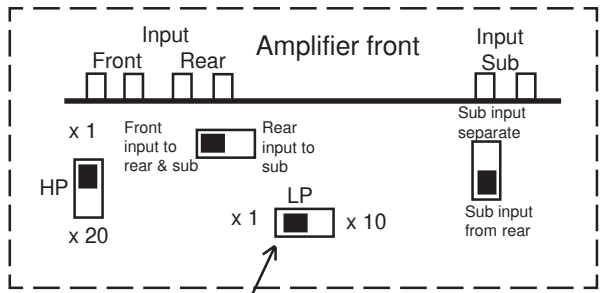

LP x10 switch under the bottom plate

Highpass filter on rear channels

This **HP-filter** is normally used as a high pass filter blocking very low frequencies from reaching the speakers. It is mostly used at say 80 Hz to protect small speakers (like 6 inch and smaller) from deep bass.

The slope of the HP-filter is 12 dB / octave.

The filter can be switched off if you want to run the amplifier in full range mode.

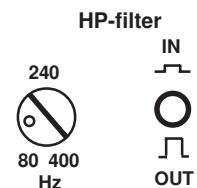

Professional Tip:
NOISE PROBLEMS
WHINING NOISE VARYING WITH ENGINE REVOLUTIONS:
Do this:

1. Rewire the power supply (12 V) to source unit direct from battery.
2. Rewire ground wire from source unit to clean position on chassis.
3. Check all power connections to ensure that they are clean and tight.
4. Check quality of system ground connection.
5. Install a Power Cap capacitor. This can be helpful against most noise problems.

CONSTANT WHINING NOISE:
Do this:

1. Ensure that all equipment has a common ground point.
2. Check quality of earth strap connection from battery negative terminal to chassis.
3. Disconnect signal cables from amplifier to see if noise disappears. If so the leads are picking up noise. Test this by laying a new cable over the seats and reconnecting to the amplifier. If the noise does not return, re-route original cable away from source of interference.
If noise remains regardless of cable position, try to use so called Quasi-balanced signal cables. DLS PRO and Ultimate-cables are Quasi-balanced.

Professional Tip:
SPEAKER POLARITY CHECK.

All speakers in a car audio system should be connected in phase (the same polarity). All speaker cones must move in the same direction. Out of phase speakers will cause a lack of bass, and a poor stereo soundstage.

Checking polarity:

Hold the - connection of the speaker wire to the - terminal of a 1,5 Volt flashlight battery. Tap the + wire on to the + terminal of the battery, and observe the movement of the cone. The cone should move outwards when the wire touches the battery, and inwards when the battery is removed. If it is the other way around, the speaker has been connected backwards and it must be removed and connected correctly.

If your system also has a subwoofer connected through a passive 6 or 12 dB crossover, try to connect this with various polarity and judge what sounds best. The phase shift in passive crossovers sometimes makes it necessary to change polarity.

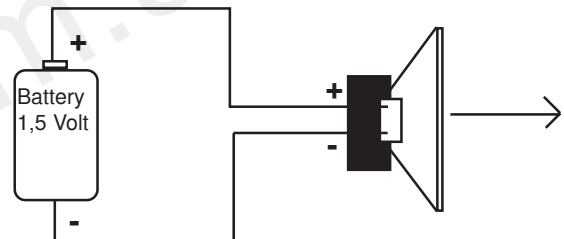

NOTE! Tweeters can not be tested this way, double check the connections instead.

Professional Tip:
Installing in trunk

When installing the amplifier in the trunk, run the power wires along the same path as the other vehicle wiring. Many cars have insulated channels for wiring. you will have to remove the door sill trim and the carpet.

Professional Tip:
Securing wires

Use wire ties to bundle together when possible. (But never bundle speaker wires or signal cables together with power wires).

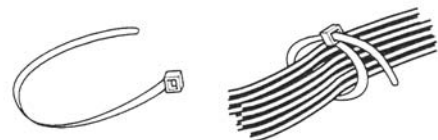
Professional Tip:
Crimp connections

Purchase crimp connectors and crimping tool. Connectors are color coded.

1. Strip 1/4 inch (6 mm) of insulation from the wire.
2. Insert into connector
3. Crimp tightly

Professional Tip:
Speaker and power wires

Do not run speaker and power wires next to each other. Power wires can generate a "siren" sound in the speakers. Run speaker and power wires on opposite sides of the car.

Wiring examples DLS A2

On the following pages you find some examples of how to connect the amplifier for different use. The drawings show normal level and filter settings.

DLS A2 can be connected in different ways:

- As a stereo amplifier connected with a speaker system of coaxial, 2-way or 3-way type.
Two speaker systems can be connected in parallel, one front and one rear system.
- As a subwoofer amplifier with max two 4 ohm subwoofers in mono bridge mode. The built-in lowpass crossover is used. (Connect to L+ and R-).
DLS A2 has an inbuilt adjustable lowpass filter that should be set to approx. 70-80 Hz.

1. One speaker pair connected in stereo

You can use all DLS coaxial, 2-way or 3-way systems in this example. The speaker impedance must be 4 ohm.

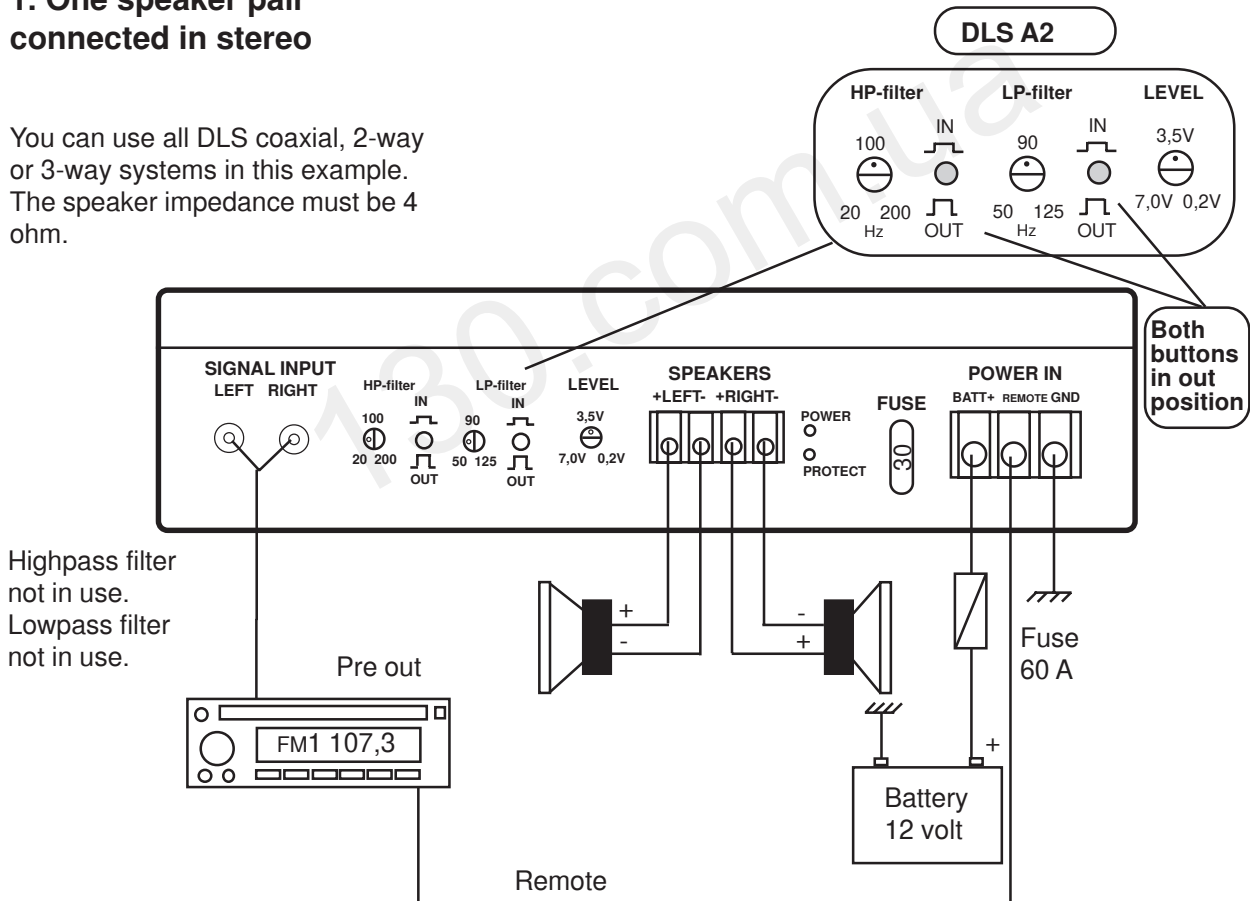

For power cable, speaker cable and fuse size selection we refer to page 4.

Use a 2 mm hex key to speaker terminals.
 Use a 4 mm hex key to DC input terminals on

If you have problems with the mid bass driver "reaching the bottom" (the voice coil touches the bottom pole plate) at high volumes, use the HP-filter to avoid this with a setting at 50 - 80 Hz or higher. Make your own tests.



2. Two stereo speaker pairs connected in parallel

If you have problems with the mid bass driver "reaching the bottom" (the voice coil touches the bottom pole plate) at high volumes, use the HP-filter to avoid this with a setting at 50 - 80 Hz or higher. Make your own tests.

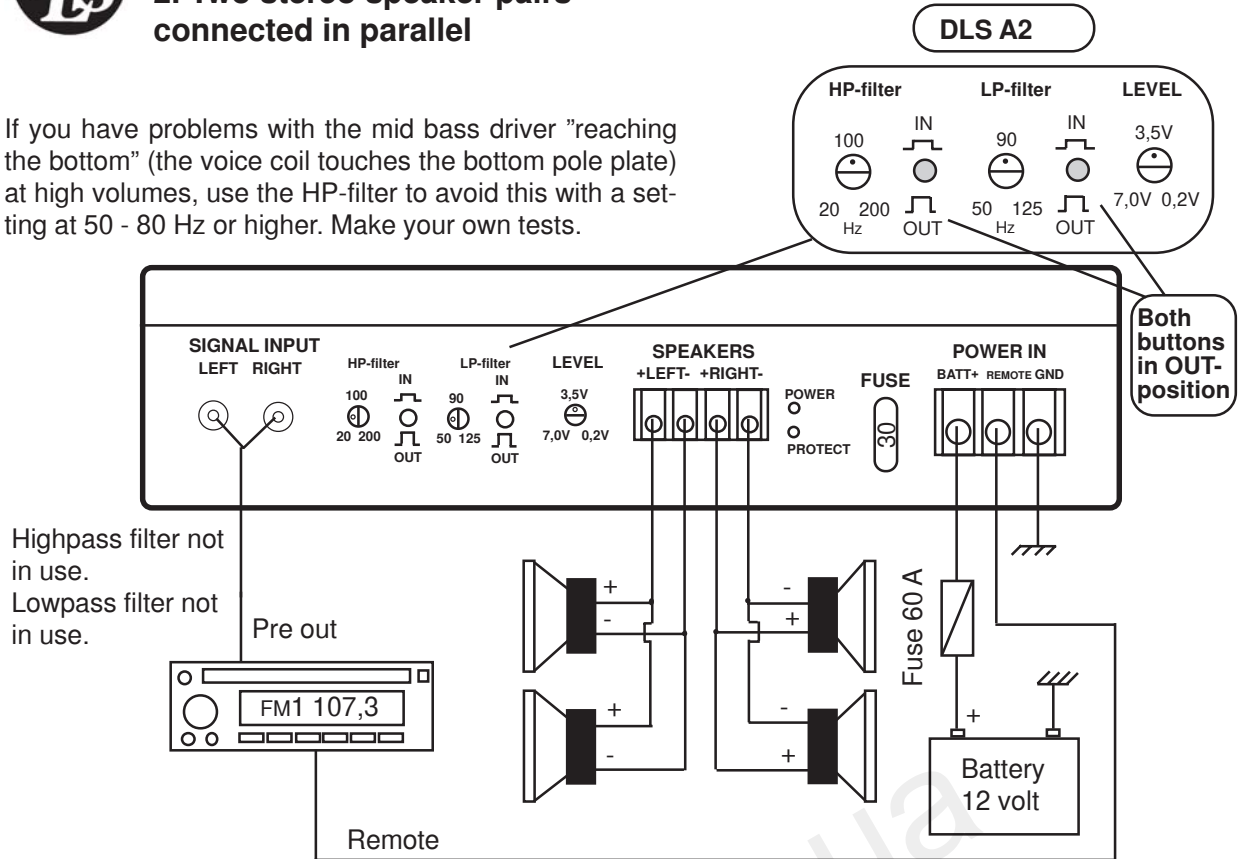

3. Connection in mono with one subwoofer in bridge mode.

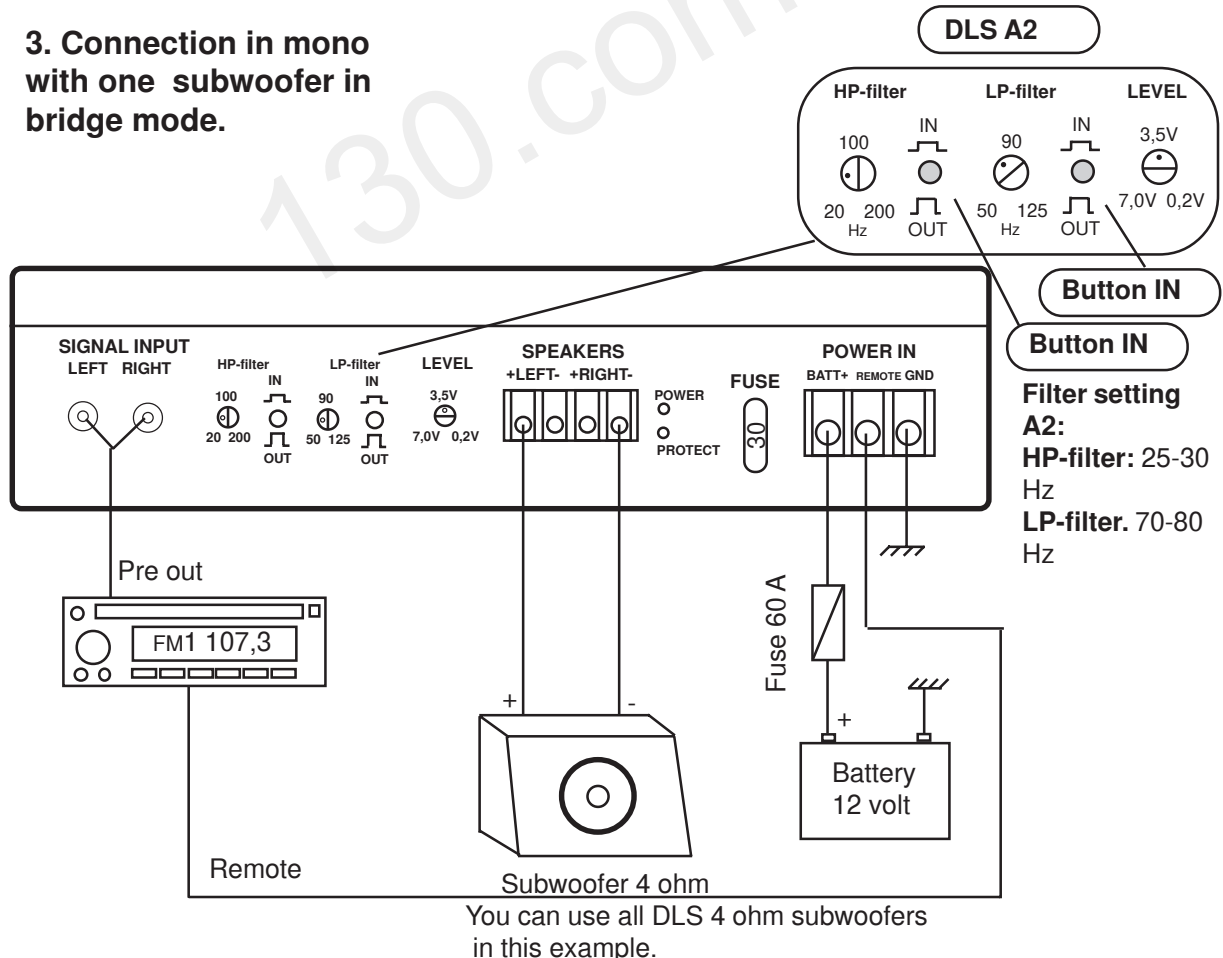

For power cable, speaker cable and fuse size selection we refer to page 4.

WIRING EXAMPLES DLS A3

On the following pages you find some examples of how to connect the amplifier for different use. The drawings show normal level and filter settings. The two channels are divided into two separate mono amplifiers. There are separate DC inputs for each channel but they are internally connected with each other. You can feed the amplifier with double DC feeds if you want a minimum of voltage drop, or you can also use the extra DC-input for the connection of a Power capacitor as in the example.

DLS A3 can be connected in different ways:

- As a stereo amplifier connected with a speaker system of coaxial, 2-way or 3-way type.
Two speaker systems can be connected in parallel, one front and one rear system.
- As a subwoofer amplifier with max two 4 ohm subwoofers in mono bridge mode. The built-in lowpass filter is used. (Connect to L+ and R-).

1. In stereo with one front and one rear speaker system.

You can use all DLS coaxial, 2-way or 3-way speaker systems in this example. Speaker impedance must be 4 ohm.

For power cable, speaker cable and fuse size selection see page 4.

DC-FEED DLS A3

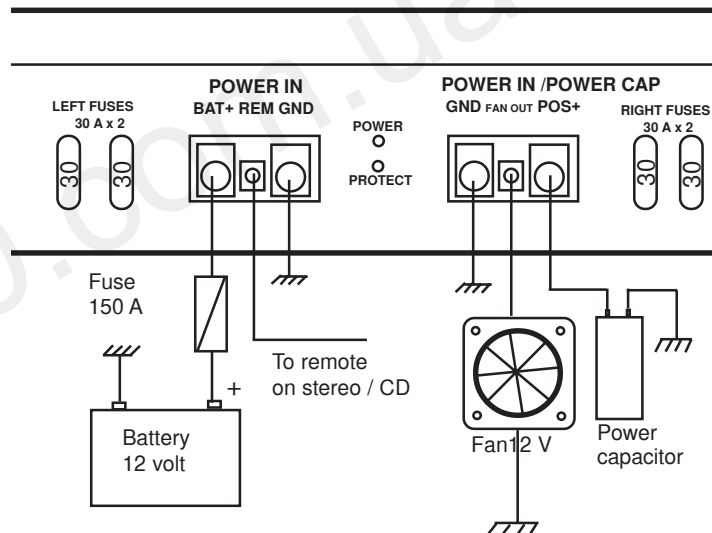

Highpass filter not in use.
Lowpass filter not in use.

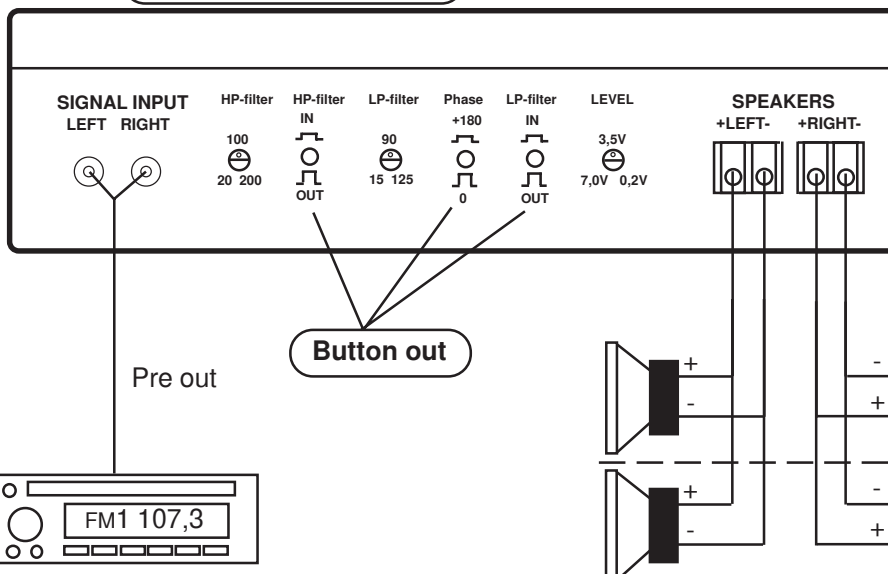

If you have problems with the mid bass driver "reaching the bottom" (the voice coil touches the bottom pole plate) at high volumes, use the HP-filter to avoid this with a setting at 50 - 80 Hz or higher. Make your own tests.

2. One or more subwoofers in mono bridge mode

You can use all DLS subwoofers in this example.

Speaker impedance must be 4 ohm.

For power cable, speaker cable and fuse size selection see page 4.

Adjust the HP- and LP-filter settings as in the drawing

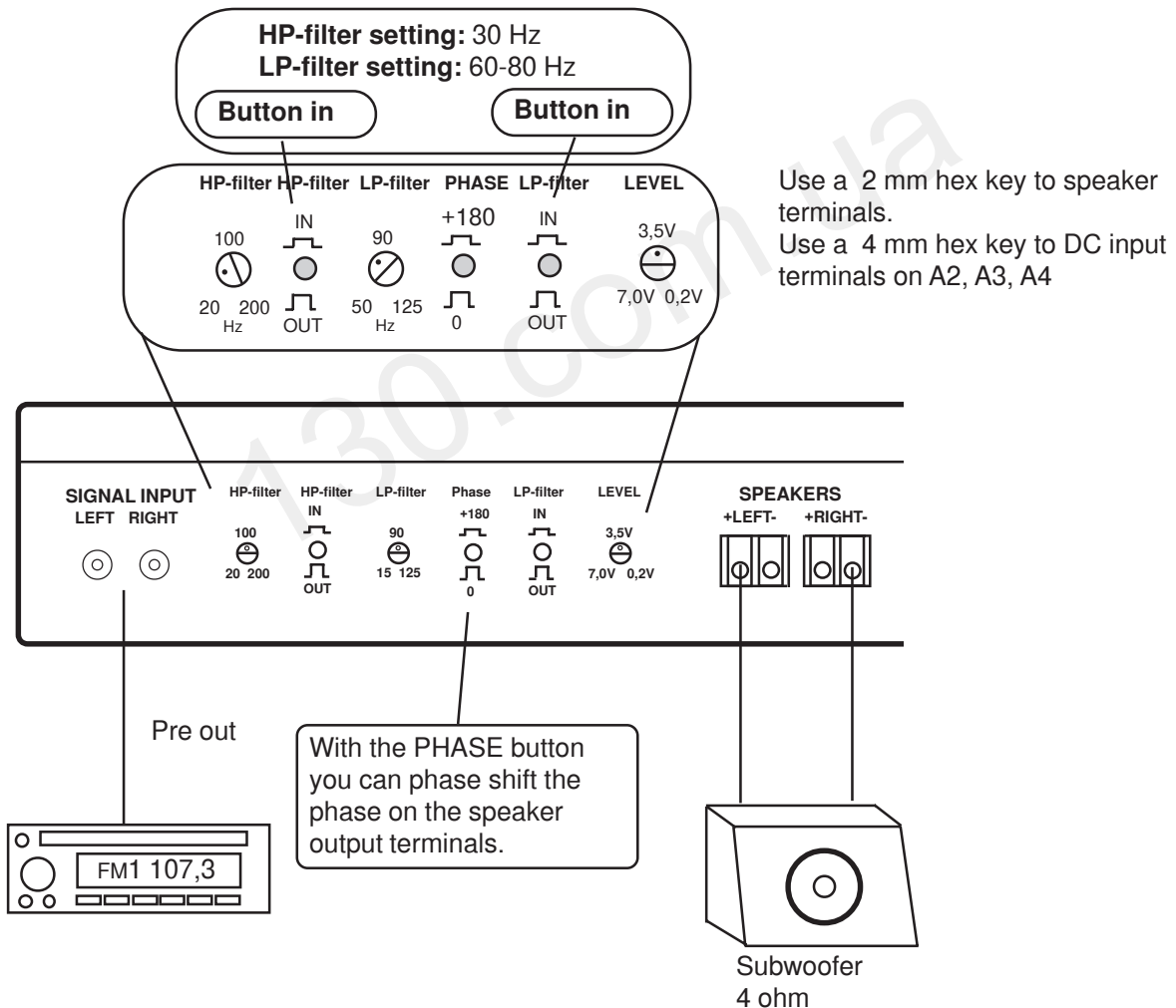
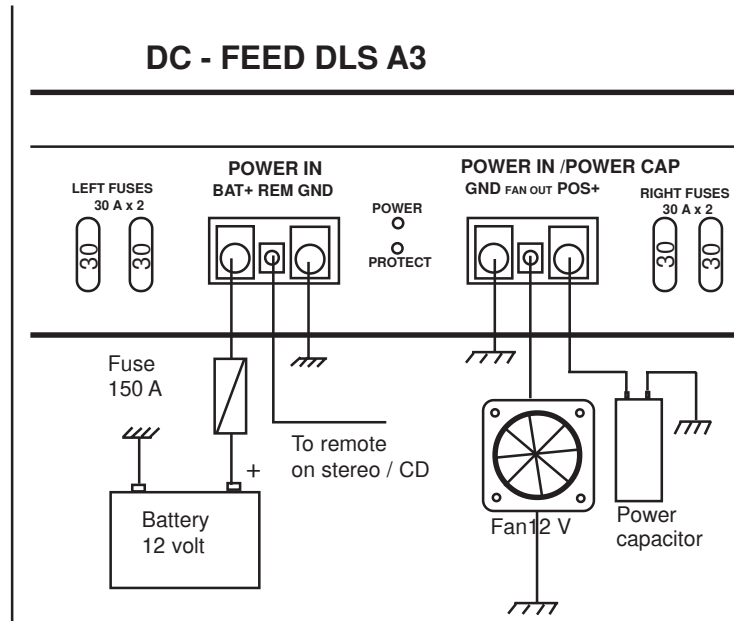

DLS A3 is 0,75 ohm stable. This means that you can connect three 4 ohm subwoofers in parallel without damaging the amplifier. Two 4 ohm subwoofers connected in parallel results in a 2 ohm load which the amplifier sees as a 1 ohm load. Three subwoofers gives a 1,33 ohm load which the amplifier sees as a 0,75 ohm load.

WIRING EXAMPLES A4

1. Connecting a front system in stereo and a subwoofer in mono bridge mode.

You can use all DLS coaxial, 2-way, 3-way systems and subwoofers in this example.

All speakers must be 4 ohm.

If the head unit has only one pre out a Y-cable must be used.

For power cable, speaker cable and fuse size selection see page 4.

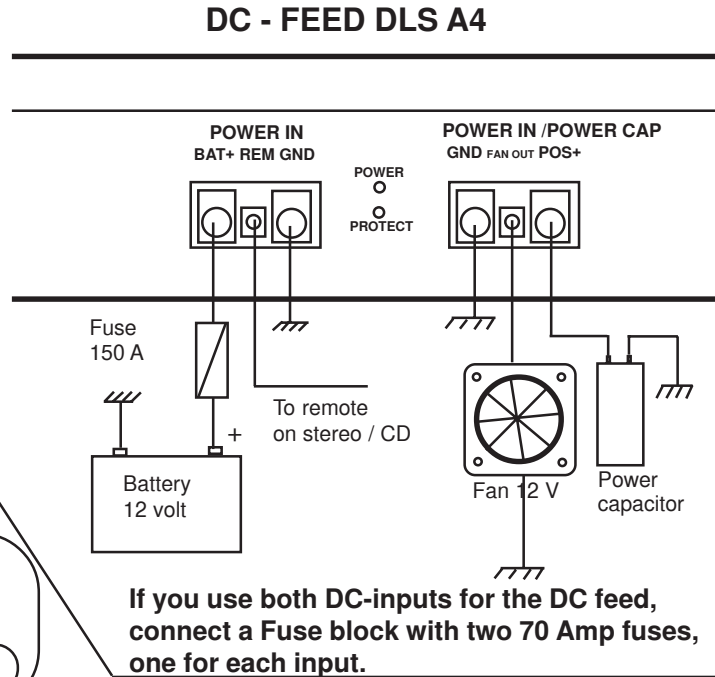

HP-filter setting: 80-100 Hz
LP-filter not in use

Button in

Button out

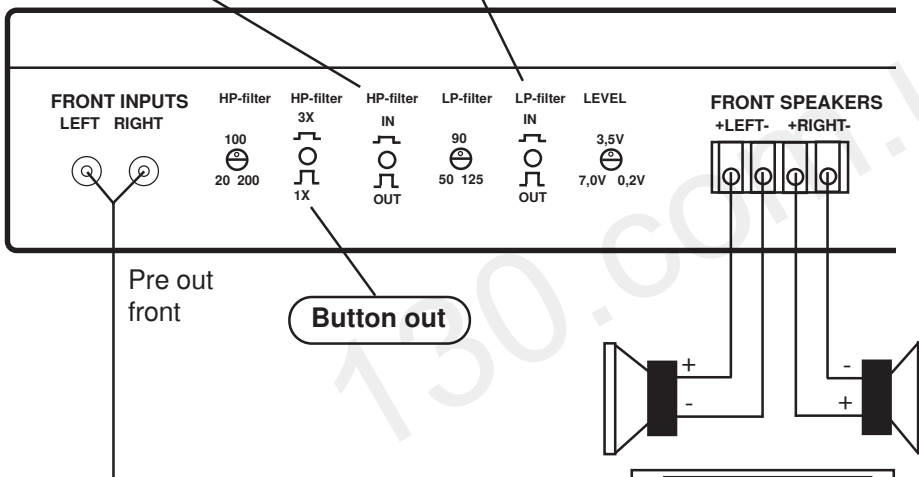

HP-filter setting: 30 Hz
LP-filter setting: 70-80 Hz

Button in

Button in

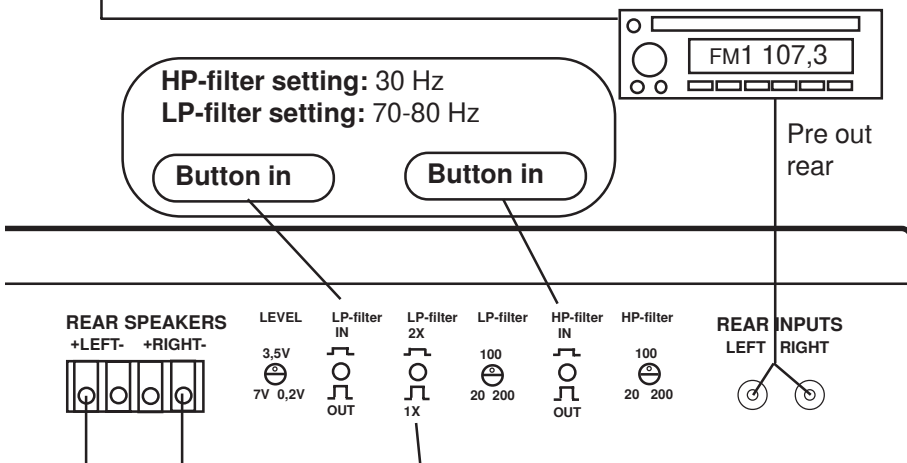

Use a 2 mm hex key to speaker terminals.
Use a 4 mm hex key to DC input terminals on A2, A3, A4

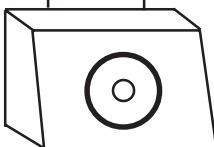

Subwoofer 4 ohm

DLS A4 is 1 ohm stable. This means that you can connect two 4 ohm subwoofers in parallel without damaging the amplifier. Two 4 ohm subwoofers connected in parallel results in a 2 ohm load which the amplifier sees as a 1 ohm load. If you have a 4 ohm sub with dual voice coils you can connect the coils in parallel.

2. A front system connected in stereo bridge mode on all four channels.

You can use all DLS coaxial, 2-way or 3-way speaker systems in this example.

Speaker impedance must be 4 ohm. If the head unit has only one pre out a Y-cable must be used.

For power cable, speaker cable and fuse size selection see page 4.

DC-FEED DLS A4

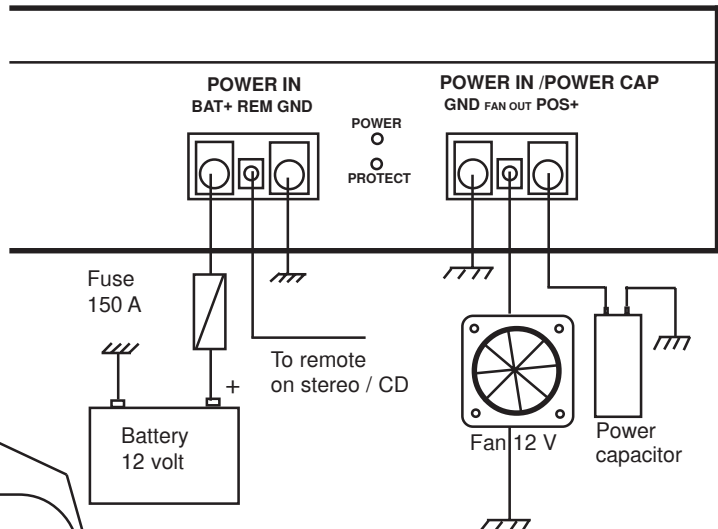

If you use both DC-inputs for the DC feed, connect a Fuse block with two 70 Amp fuses, one for each input.

HP-filter not in use.
LP-filter not in use.

Button out

Button out

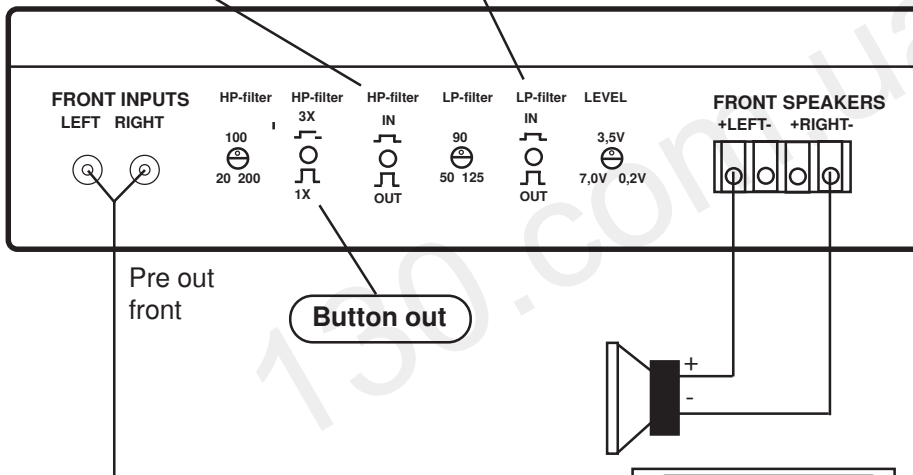

If you have problems with the mid bass driver "reaching the bottom" (the voice coil touches the bottom pole plate) at high volumes, use the HP-filter to avoid this with a setting at 50 - 80 Hz or higher. Make your own tests.

HP-filter not in use.
LP-filter not in use.

Button out

Button out

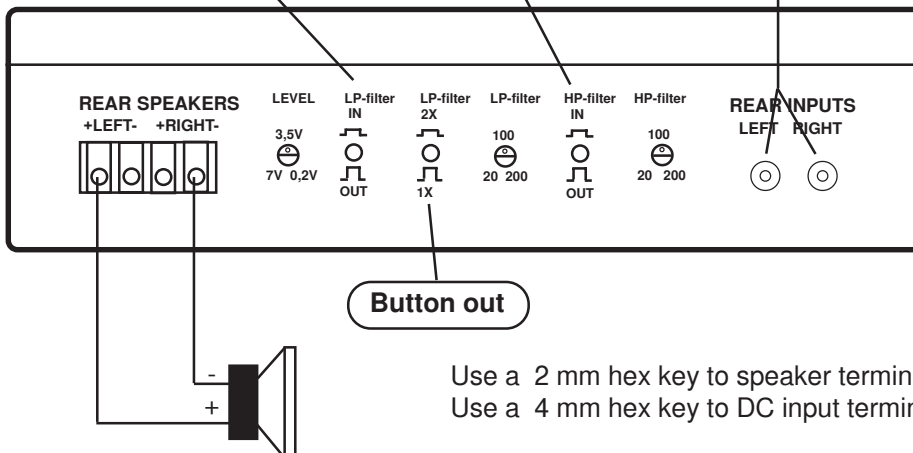

Use a 2 mm hex key to speaker terminals.
Use a 4 mm hex key to DC input terminals on A2, A3, A4

DC-FEED DLS A4

3. Connecting a 3-way system using active crossover between woofer and midrange.

You can use all 3-way speaker systems in this example. You can also use any 2-way system in combination with a separate mid bass speaker. Speaker impedance must be 4 ohm. If the head unit has only one pre out a Y-cable must be used.

For power cable, speaker cable and fuse size selection see page 4.

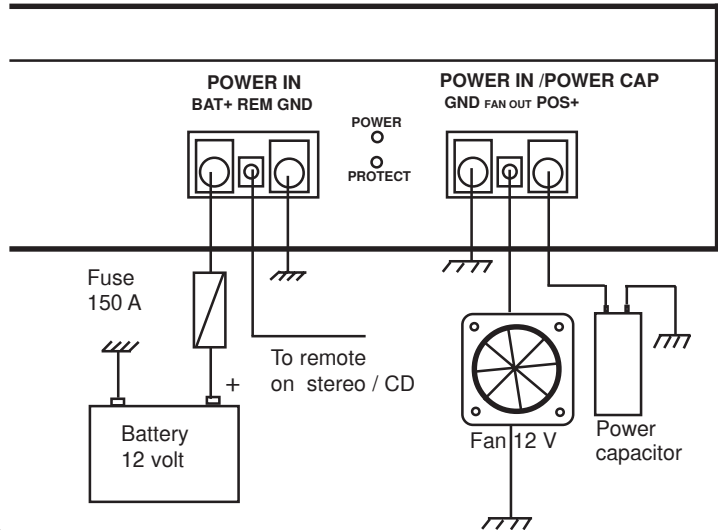

If you use both DC-inputs for the DC feed, connect a Fuse block with two 70 Amp fuses, one for each input.

HP-filter setting: 400 Hz
LP-filter not in use

Button in

Button out

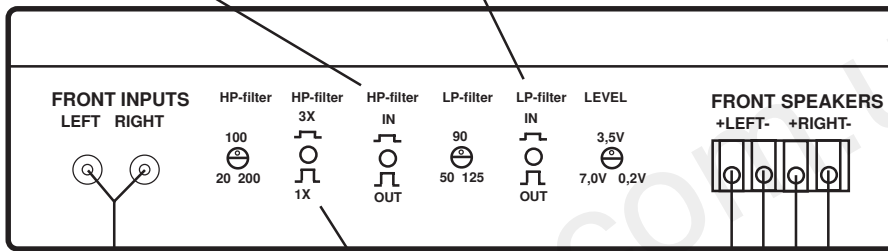

Button in

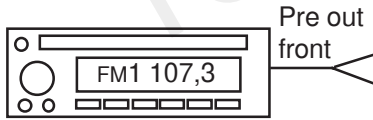

HP-filter not in use
LP-filter setting: 400 Hz

Button in

Button out

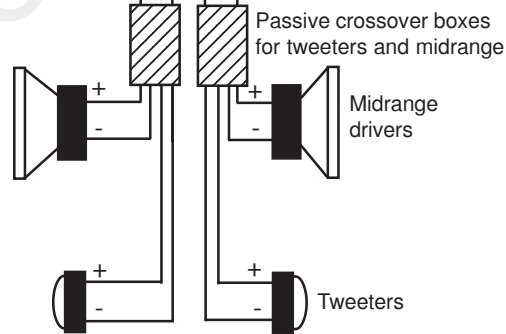

If you have problems with the mid bass driver "reaching the bottom" (the voice coil touches the bottom pole plate) at high volumes, use the HP-filter to avoid this with a setting at 50 - 80 Hz or higher. Make your own tests.

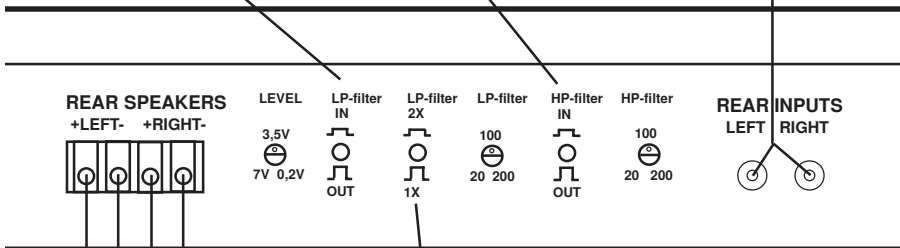

Button in



Use a 2 mm hex key to speaker terminals.
Use a 4 mm hex key to DC input terminals on A2, A3, A4

WIRING EXAMPLES A5

Connection of a front system in stereo and a subwoofer in mono.

You can use all DLS coaxial, 2-way, 3-way systems and subwoofers in this example.

All speakers must be 2-4 ohm. If the head unit has only one pre out, a Y-cable must be used.

For power cable, speaker cable and fuse size selection see page 4.

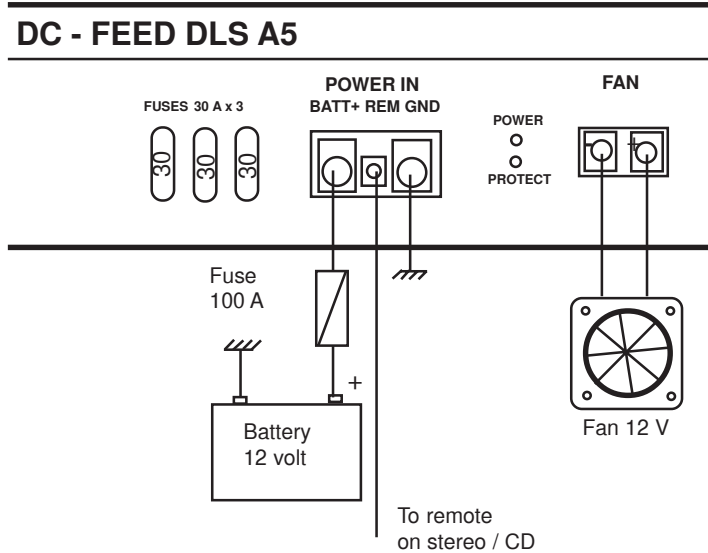

Use a 2 mm hexagon key to speaker and fan terminals. Use a 2,5 mm hexagon key to the remote terminal. Use a 3 mm hexagon key to DC input terminals.

DLS A5 front channels are 1 ohm stable. DLS A5 mono channel is 1 ohm stable. This means that you can connect three 4 ohm subwoofers in parallel without damaging the amplifier.

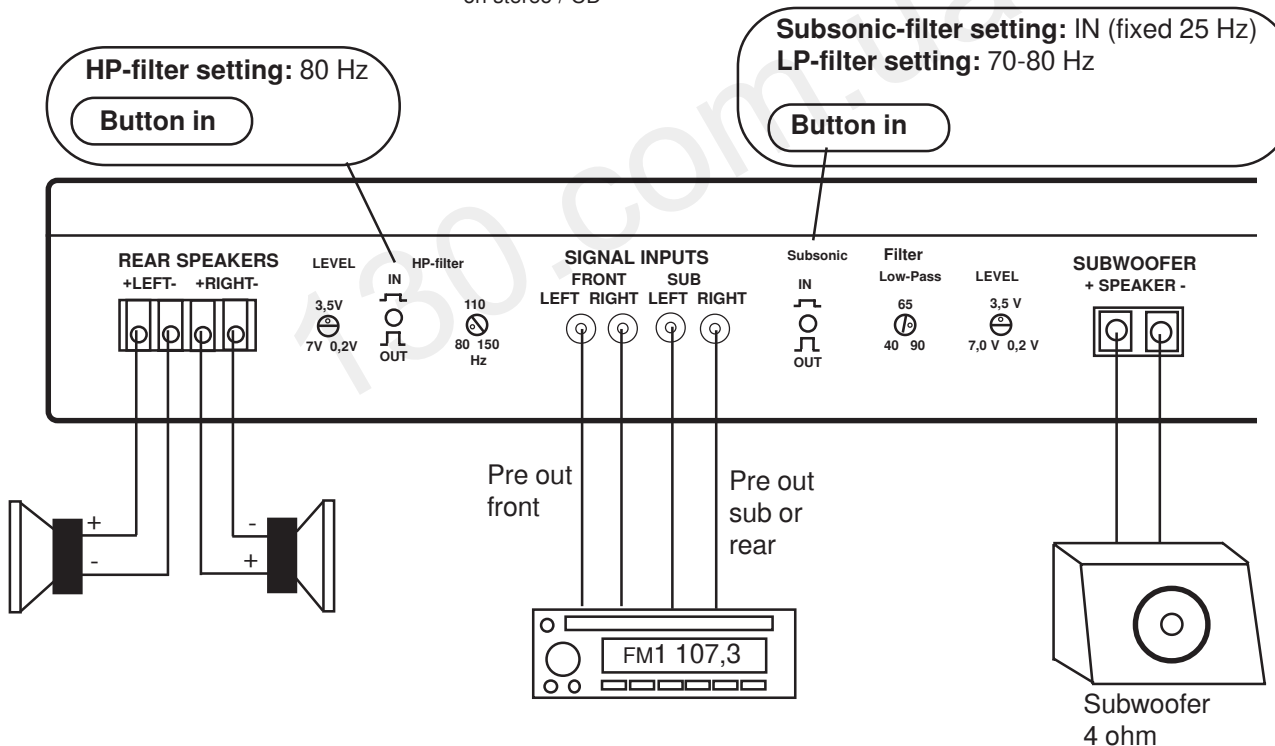

Left side of A5 (part of)

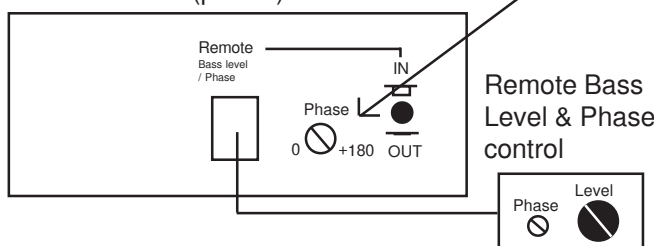

PHASE SHIFT CONTROL

The Phase shift control is variable from 0 to +180 degrees. With this control you can fine tune your subwoofers so they play in phase with the rest of your system.

REMOTE BASS LEVEL & PHASE SHIFT

A remote bass level & phase shift control is included. This allows you to adjust the bass level and phase shift from the front seat of your car.

Connect it to the socket marked Remote Bass Level. When using a remote level control you must activate it by pushing the switch on the right side of the socket, to IN-position.

WIRING EXAMPLES A6

Connection of two 4 ohm subwoofers

You can use all DLS subwoofers in this example. All speakers must be 2-4 ohm. If you have subwoofer with dual voice coils, connect one voice coil to each output terminal. For power cable, speaker cable and fuse size selection we refer to page 2.

PHASE SHIFT CONTROL

The Phase shift control is variable from 0 to +180 degrees. With this control you can fine tune your subwoofers so they play in phase with the rest of your system. This feature is extremely useful when fine tuning the different speakers and amplifiers of a SPL competition vehicle.

REMOTE BASS LEVEL & PHASE SHIFT

A remote bass level & phase shift control is included. This allows you to adjust the bass level and phase shift from the front seat of your car. Connect it to the socket marked Remote Bass Level. When using a remote level control you must activate it by pushing the switch on the left side of the socket, to IN-position.

DC - FEED DLS A6

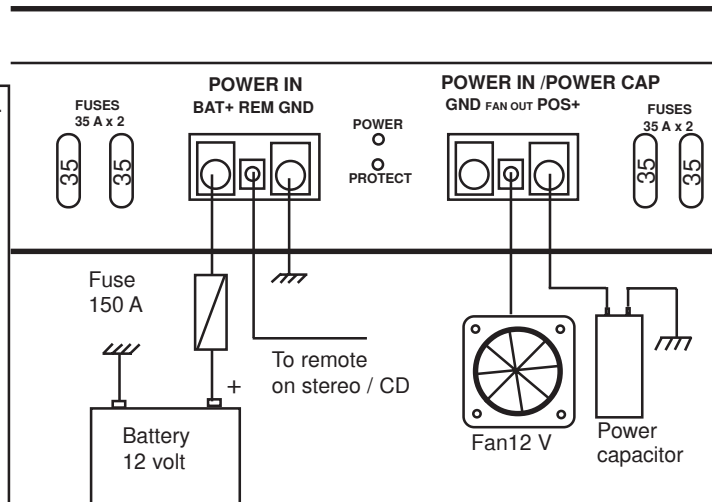

Subsonicfilter setting: IN (fixed 25 Hz)
LP-filter setting: 70-80 Hz

Button in

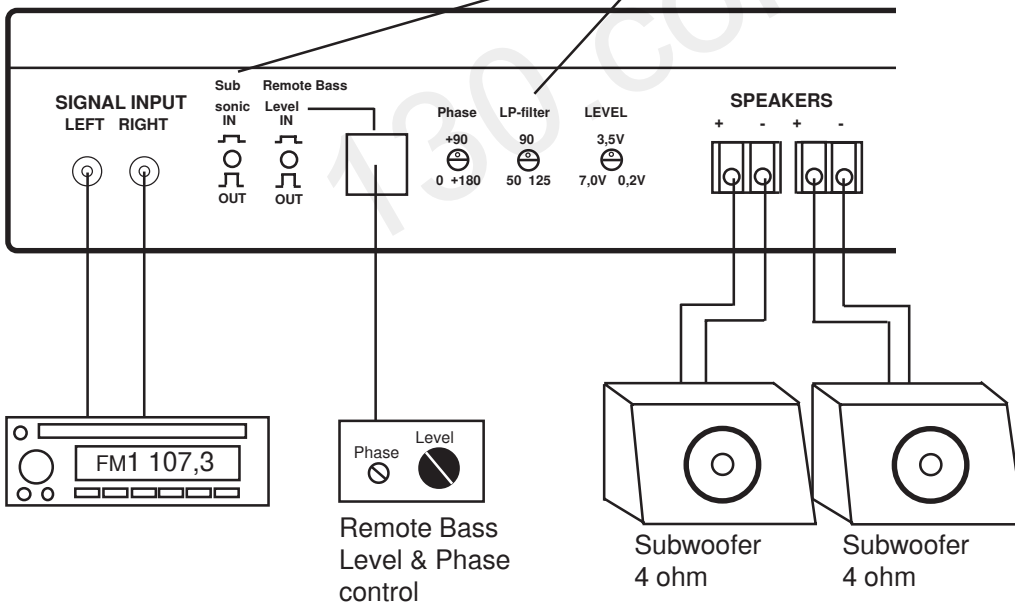

DLS A6 has a built-in fan for cooling. The fan is mounted in the bottom plate of the amplifier. To get the best performance and cooling, mount the amplifier on spacings. Doing so the fan can get fresh air for best possible cooling. The amplifier becomes very hot, especially when loaded down to 1 ohm. When using 1,33 and 1 ohm loads we recommend the use of external cooling fans as well.

DLS A6 is 1 ohm stable. This means that you can connect four 4 ohm subwoofers in parallel without damaging the amplifier. If you have a 4 ohm sub with dual voice coils you can connect the coils in parallel, one coil to each amplifier output.

NOTE!

The speaker output terminals are internally connected in parallel. This is a mono amplifier so it is not able to connect the outputs in bridge mode. The double terminals are only for easier connection of more than one subwoofer.



WIRING EXAMPLES A7

Example 1: Speaker wiring with front speakers, rear speakers and one or more subwoofers

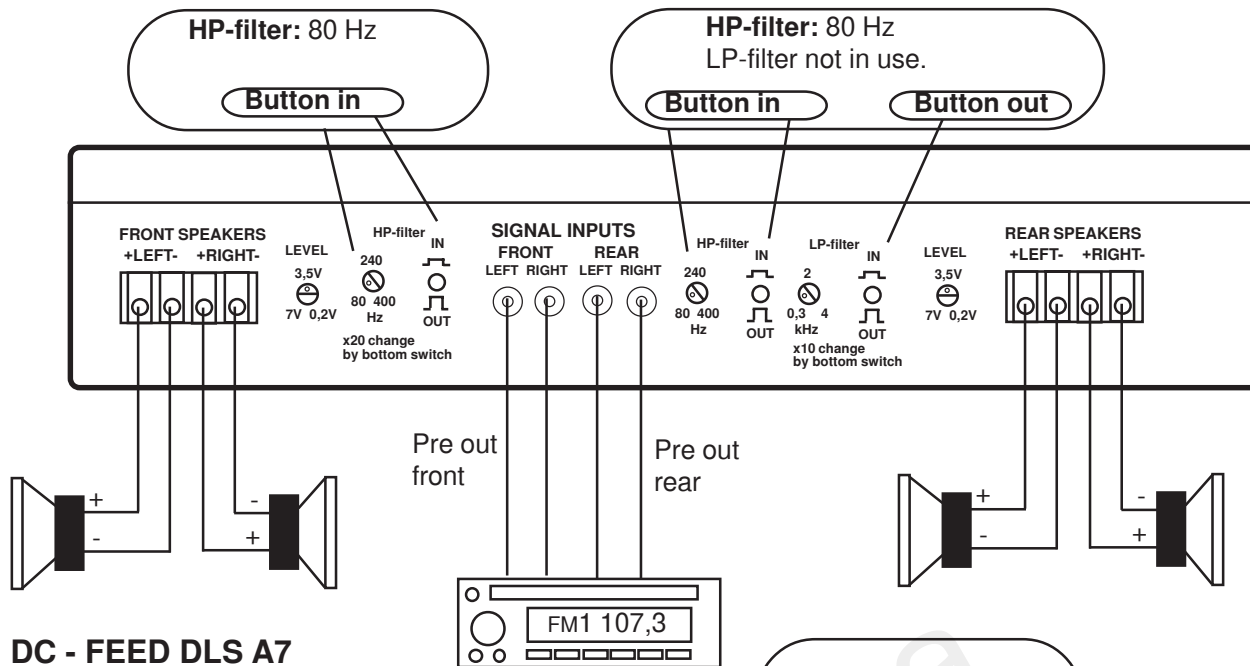

DC - FEED DLS A7

For DC-feed, see page 4

If you have problems with the mid bass driver "reaching the bottom" (the voice coil touches the bottom pole plate) at high volumes, use the HP-filter to avoid this with a setting at 50 - 80 Hz or higher. Make your own tests.

A7 IN BRIDGE MODE

You can connect the stereo channels in bridge mode if you prefer. Connect between L+ and R- on the respective channel pair. Use Y-cables to feed the same signal to FRONT left & right channel pair, respective REAR left & right channel pair.

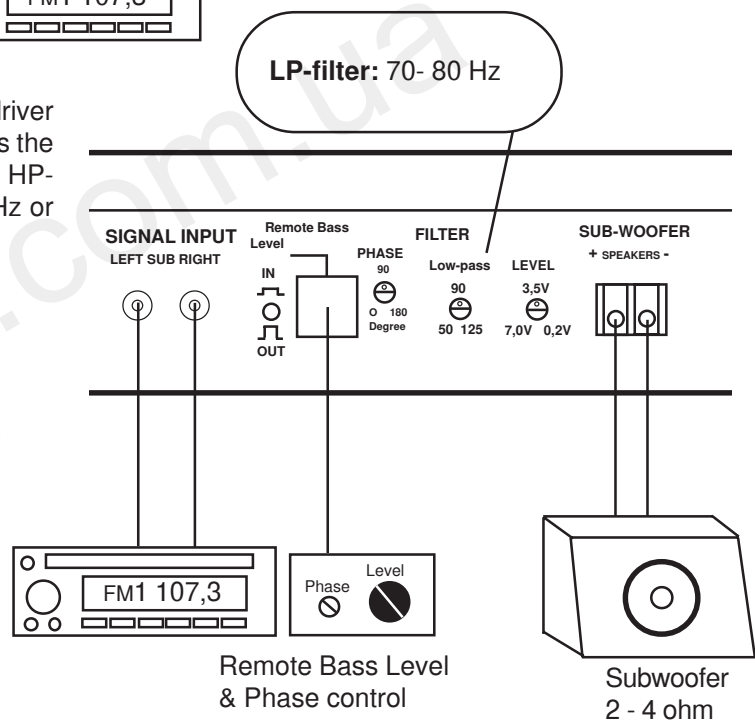

Filter settings:

Front: HP-filter 80 Hz or fullrange

Rear: HP-filter 80 Hz or fullrange
LP-filter OUT

Sub: LP-filter 70-80 Hz

Use one, two or three RCA-cables for signal from head unit to amplifier. See page 6 for detailed instructions

Switch settings in this example

HP: x1

LP: x1

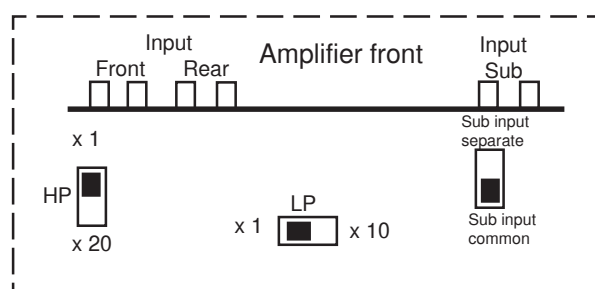

WIRING EXAMPLES A7

Example 2: Speaker wiring with active crossover to a front speaker system and one or more subwoofers

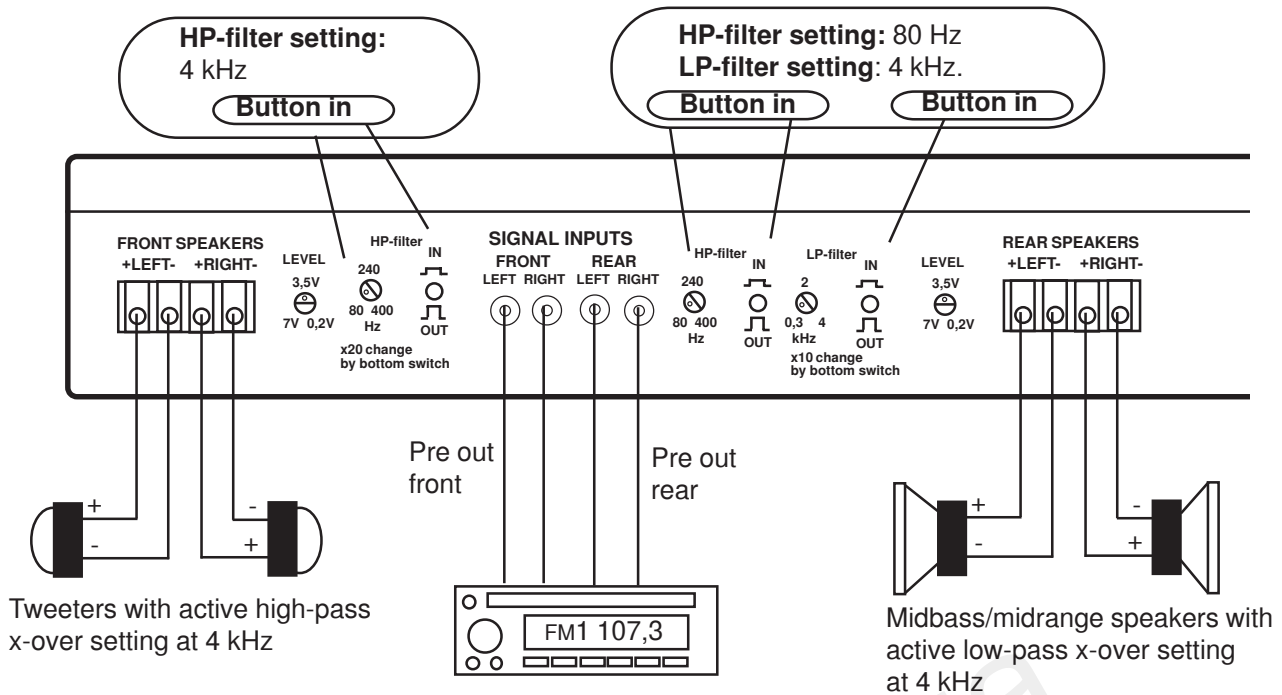

DC - FEED DLS A7

For DC-feed, see page 4

If you have problems with the mid bass driver "reaching the bottom" (the voice coil touches the bottom pole plate) at high volumes, use the HP-filter to avoid this with a setting at 50 - 80 Hz or higher. Make your own tests.

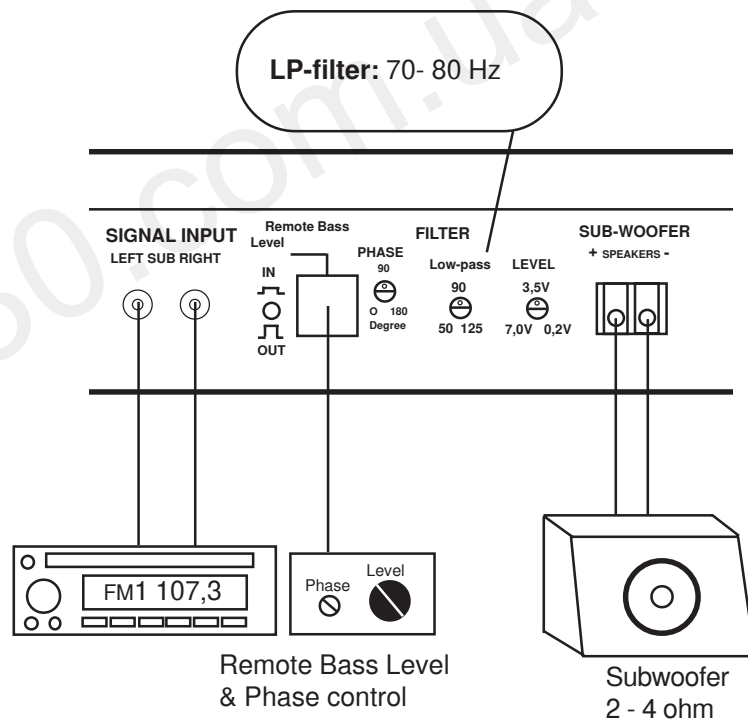

Filter settings:

- Front:** HP-filter 4 kHz with x20-switch in x20 position
- Rear:** HP-filter 80 Hz or fullrange LP-filter IN, setting 4 kHz with x10 switch in position x1
- Sub:** LP-filter 70-80 Hz

Use one, two or three RCA-cables for signal from head unit to amplifier. See page 6 for detailed instructions

Switch settings in this example

HP: x20
LP: x1

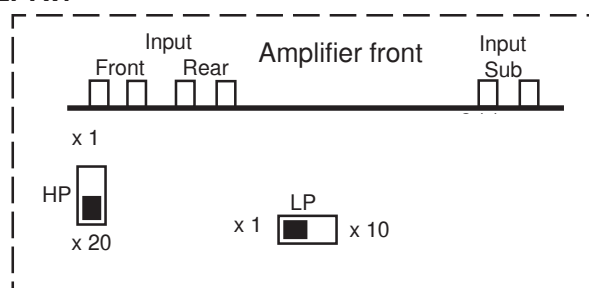

WIRING EXAMPLES A7

Example 3: System with front speaker system, rear fill speakers and one or more subwoofers

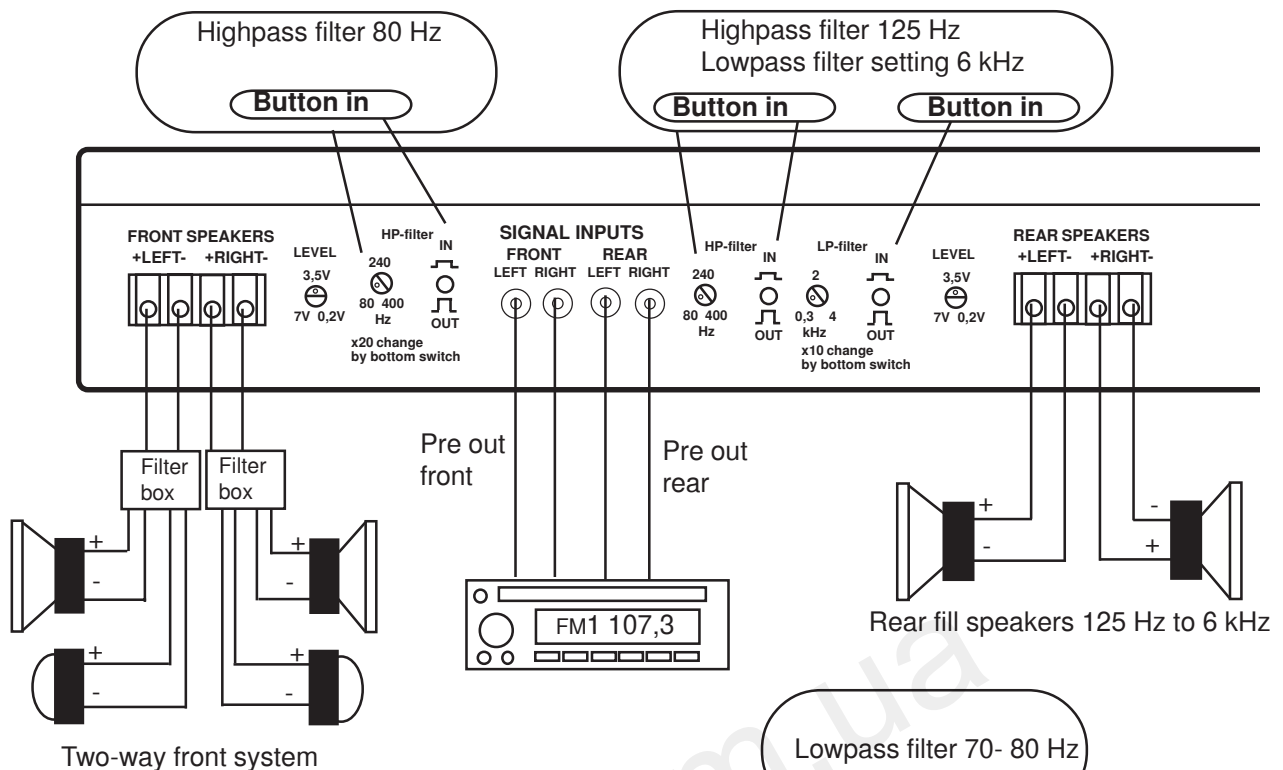

DC - FEED DLS A7

For DC-feed, see page 4

If you have problems with the mid bass driver "reaching the bottom" (the voice coil touches the bottom pole plate) at high volumes, use the HP-filter to avoid this with a setting at 50 - 80 Hz or higher. Make your own tests.

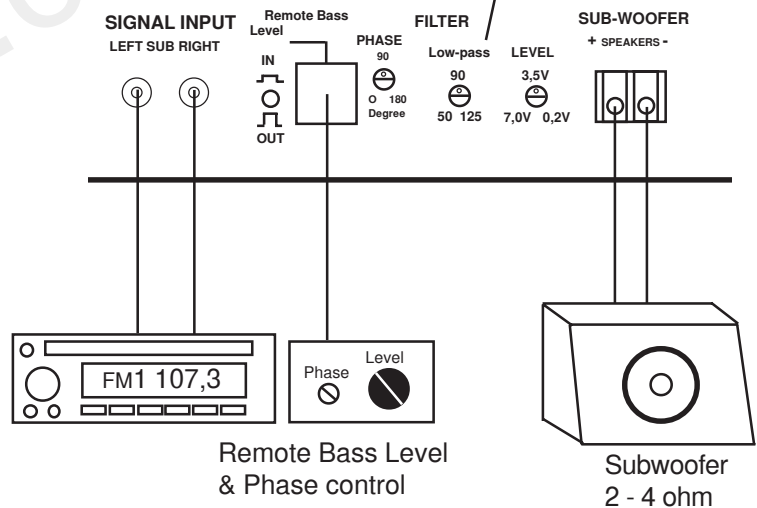

Filter settings:

Front: HP-filter 80 Hz or fullrange

Rear: HP-filter 125 Hz

LP-filter IN. Setting 6 kHz with x10 switch in position x10

Sub: LP-filter 70-80 Hz

Use one, two or three RCA-cables for signal from head unit to amplifier. See page 5 for detailed instructions

Switch settings in this example

HP: x1

LP: x10

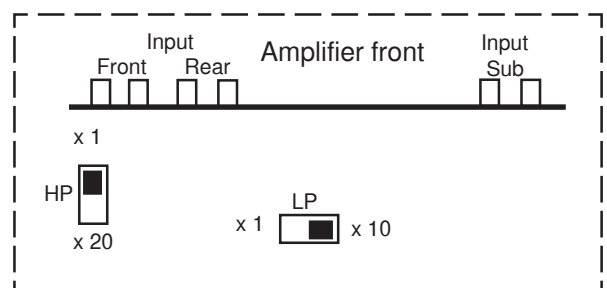

WIRING EXAMPLES A7

Example 4: Speaker wiring with active/passive crossover to a 3-way front speaker system and one or more subwoofers

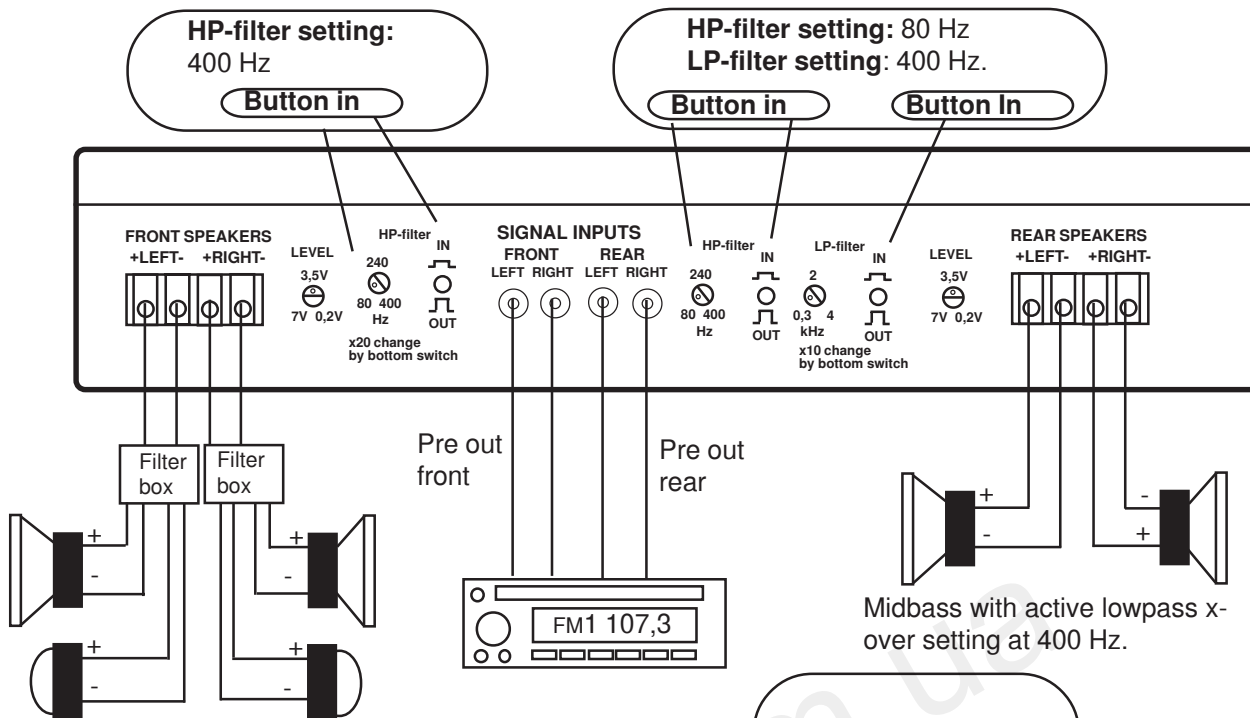

Midrange and tweeters with active highpass x-over setting at 400 Hz.
Passive x-over between midbrange and tweeters

DC - FEED DLS A7

For DC-feed, see page 4

If you have problems with the mid bass driver "reaching the bottom" (the voice coil touches the bottom pole plate) at high volumes, use the HP-filter to avoid this with a setting at 50 - 80 Hz or higher. Make your own tests.

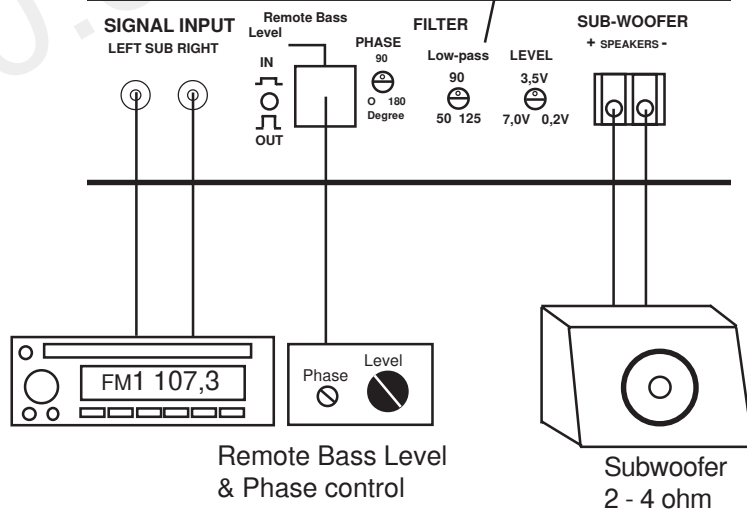

Filter settings:

Front: HP-filter 400 Hz with x20-switch in x1 position

Rear: HP-filter 80 Hz or fullrange
LP-filter IN, setting 400 Hz with x10 switch in position x1

Sub: LP-filter 70-80 Hz

Use one, two or three RCA-cables for signal from head unit to amplifier.
See page 5 for detailed instructions

Switch settings in this example

HP: x1

LP: x1

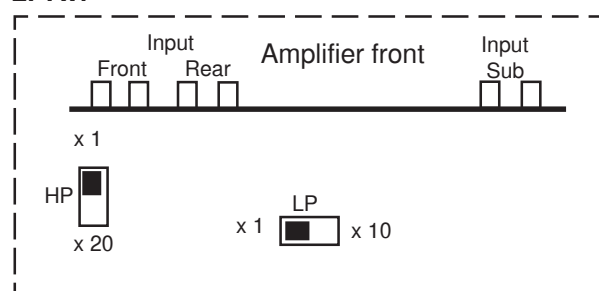

Testing

Before you finish the installation, you should do the following tests to make sure the wiring is correct and everything is operating properly.

Reconnect Battery

When wiring is complete, reconnect the battery negative terminal.

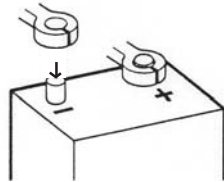

Test power wiring

1. Turn on the head unit but do not turn up the volume. The amplifier power light should come on. If not, check the remote and +12 volt wires. Also check the ground connection.
2. Turn up the head units volume slightly. All speakers should operate. If not, check wiring connections at amplifier and speakers.

Test speaker connections

Make sure the speakers are connected right. Use the balance control on the head unit to make sure right channel is on right speaker etc. If speakers don't play at all, one or both speaker wires may be disconnected.

Troubleshooting

If problems occur during the installation, or later, this guide might help you to find out what's wrong.

THE AMPLIFIER IS DEAD:

1. Check power lead, ground and remote connections at the amplifier using a multi meter.
2. Check the battery terminal connections.
3. Check the power lead fuse or circuit breaker. If fuse damage continues, inspect the power lead for short circuits.
4. Check the amplifier protection fuses. Are these broken change to new ones with the same value. If short circuiting continues, contact your local DLS dealer. A fault may exist in the amplifier.
5. To start the amplifier requires a remote voltage of 9-15 volt. Check the voltage with a multimeter.

AMPLIFIER PROTECTION FUSE BLOWS AT LOW VOLUME :

1. One or more speaker cables are shorted. Make an insulation test with a multi meter. The cables must not have a connection to earth.

THE AMPLIFIER TURNS OFF AFTER 10 - 30 MINUTES.

The amplifier is overheating due to inadequate ventilation. Check mounting position is free from obstruction.

Do this:

1. Move the amplifier to a place with better ventilation.
2. Install one or two fans to cool down the heat-sink.
3. Overheating can also be caused by an impedance load below the level permitted.

NO OUTPUT FROM ONE OR MORE SPEAKERS:

Check the following:

1. Balance control position.
2. Fader control position.
3. Speaker cable connections to both amplifier and drivers.
4. Signal lead plugs and cables.
5. Change left and right signal lead plugs in the amplifier to see if the problem moves to a different speaker, the lead has a fault. If the problem remains, the speaker or amplifier are at fault.



SPECIFICATIONS A2 to A6

Model	A2	A3	A4
Number of channels	2	2	4
Working mode	AB	AB	AB
Power output at 13,8 Volt, 20 Hz - 20 kHz, THD max 0,1%:			
Power output in 4 ohm	2 x 85 W	2 x 150 W	4 x 85 W
Power output in 2 ohm	2 x 145 W	2 x 270 W	4 x 145 W
Power output in 1 ohm	2 x 220 W	2 x 425 W	4 x 220 W
Power output, 4 ohm bridged	290 W	550 W	2 x 250 W
Power output, 2 ohm bridged	450 W	870 W	2 x 400 W
Power output, 1,33 ohm bridged		1000 W	
THD	< 0,1%	< 0,1%	< 0,1%
S/N ratio, A-weighted	> 100 dB	> 100 dB	>100 dB
Damping factor	> 200	> 200	> 200
Input impedance	10 kohm	10 kohm	10 kohm
Input sensitivity	0,2 - 7 volt	0,2 - 7 volt	0,2 - 7 volt
Filter highpass	20 - 200 Hz*	20 - 200 Hz*	see below
Filter lowpass	50 - 125 Hz*	50 - 125 Hz*	"
* can be switched in/out			
Filter slope	12 dB/octave	12 dB/octave	12 dB/octave
Fuses	30 A x 2	30 A x 4	no internal fuses
Max cable size, DC-terminal	21 mm ² (4AWG)	21 mm ² (4AWG)	21 mm ² (4AWG)
Max cable size, speaker terminal	10 mm ² (7AWG)	16 mm ² (5AWG)	10 mm ² (7AWG)
Protection	Current & thermal	Current & thermal	Current & thermal
Power consumption:			
Idle	0,6 A	1,1 A	1,5 A
Maximum	60 A	140 A	95 A
Dimensions:			
Width x Height x Depth (mm)	265 x 73 x 240	410 x 73 x 240	465 x 73 x 240
(inch)	10,43 x 2,87 x 9,45	16,15 x 2,87 x 9,45	18,3 x 2,87 x 9,45

Filter configuration DLS A4

Front:

Lowpass 50 - 125 Hz

Highpass 20 - 200 Hz or 60 - 600 Hz (x 3 button)

Rear:

Lowpass 45 - 200 Hz or 90 - 400 Hz (x 2 button)

Highpass 20 - 200 Hz

Model	A5	A6
Number of channels	3	1
Working mode	AB	AB
Power output at 13,8 Volt		
Front channels:		
Power output in 4 ohm	2 x 85 W	
Power output in 2 ohm	2 x 100 W	
Sub channel:		
Nominal power RMS in 4 ohm	300 W	500 W
Typical power RMS in 2 ohm	500 W	870 W
Typical power RMS in 1 ohm	780 W	1200 W
THD	< 0,1%	<0,1%
S/N ratio, A-weighted	> 100 dB	>100 dB
Damping factor	> 200	> 200
Input impedance	10 kohm	10 kohm
Input sensitivity	0,2 - 7 volt	0,2 - 7 volt
Filter highpass	50 - 150 Hz / 6 dB	
Filter lowpass	40 - 90 Hz / 12 dB	50 - 125 Hz / 12 dB
Subsonic filter	25 Hz / 18 dB	25 Hz / 18 dB
Phase control	0-180 degree continuous	0-180 degree continuous
Remote bass level & phase control	Included	Included
Fuses	3 x 30 A	4 x 35 A
Max cable size, DC terminal	21 mm ² (4AWG)	21 mm ² (4AWG)
Max cable size, speaker terminal	6/10 mm ² (10/7AWG)	10 mm ² (7AWG)
Protection	Current & thermal	Current & thermal
Power consumption:		
Idle	0,5 A	0,5 A
Maximum	90 A	140 A
Dimensions:		
Width x Height x Depth (mm)	410 x 73 x 240	410 x 73 x 240
(inch)	16,15 x 2,87 x 9,45	16,15 x 2,87 x 9,45



SPECIFICATIONS A7

Model A7

RMS output per channel at 13,8 volts, 20 Hz - 20 kHz , < 0,1% distortion.

Front and rear channels:

Power output in 4 ohm 4 x 60 W
Power output in 2 ohm 4 x 100 W
Power output in bridge mode 2 x 200 W

Subchannel:

Power output in 4 ohm 1 x 300 W
Power output in 2 ohm 1 x 440 W
Power output in 1 ohm 1 x 600 W
S / N ratio, A-weighted >100 dB
Damping factor >200
Input impedance >10k
Input sensitivity 0,3 - 7V
Fan output terminal Yes (max 500 mA)
Remote bass & phase control Yes
Fuses 20A x 2, 35A x2
Max cable size, DC-terminal 21 mm² (4AWG)
Max cable size, speaker terminal 10 mm² (7AWG)
Protection Current & thermal

Power consumption:

Idle 1,1 A
Maximum 120 A
Dimensions (mm) 605x240x73
Dimensions (inch) 23,82x 9,45x2,87
Weight 8,1 kg (17,86 lb)

Filter configuration DLS A7

Channel 1&2:

Highpass: 80 - 400 Hz
or 1,6 - 8 kHz (x20 switch)

Channel 3&4:

Highpass: 80-400 Hz
Lowpass: 0,3-4 kHz
or 3 - 40 kHz (x10 switch)

Subchannel:

Lowpass: 50 - 125 Hz

We follow a policy of continuous advancement in development.

For this reason all or part of specifications & designs may be changed without prior notice.



130.com.ua

DLS Svenska AB
P.O. Box 13029
S-40251 Göteborg, Sweden
Tel: +46 31 840060
Fax: +46 31 844021
E-mail: info@dls.se
www.dls.se